

# San Carlos Estates Water Control District Access Standards Handbook

Adopted by the San Carlos Estates Water Control District Board of Supervisors

Adopted by Board of Supervisors February 16, 2016

Prepared by Morris-Depew Associates, Inc. – District Engineer

## Contents

Section 1 - Purpose .....	3
Section 2 - Applicability.....	3
Section 3 - Application Requirements.....	4
Section 4 - Driveway Standards .....	7
4.1 Typical Installations.....	7
4.2 Driveway Materials .....	7
4.3 Drainage Considerations .....	8
4.4 Pipe Material.....	9
4.5 Depth of Cover Concerns .....	9
4.6 Pipe End Treatment .....	10
4.7 Temporary Driveway Construction .....	10
Section 5 - Unpaved Roadways.....	11
Section 6 - Temporary Erosion Control Requirements .....	11
Section 7 - Construction Material Specifications .....	13
Section 8 - Monitoring Submittals and Requirements.....	13
8.1 Monthly Construction Monitoring .....	13
8.2 Pre-Backfill Check.....	14
8.3 Final Certification .....	14
Section 9 - Compliance and Enforcement Actions.....	15
9.1 Unpermitted Activities.....	15
Appendix A	Site Plan Examples
Appendix B	Temporary Erosion Control & Pipe Mitered End Details
Appendix C	Roadway Typical Sections
Appendix D	Specifications
Appendix E	Spill Reporting Procedures

## **Section 1 - Purpose**

The purpose of this Handbook is to assist property owners and their contractors to understand Permitting Procedures, Policies and Requirements of the San Carlos Estates Water Control District (SCEWCD) with an emphasis on the physical creation of access to individual lots. The District receives authority to standardize these improvements as a F.S. Ch. 298 Water Control District. The SCEWCD Board of Supervisors (Supervisors) has determined that the standardization of construction is needed in order to comply with the requirements of the National Pollution Discharge Elimination System (NPDES) Municipal Separate Stormwater Sewer System (MS4) permit as a co-permittee with Lee County and Bonita Springs, and to minimize cost to the District incurred by continued development of vacant parcels within the District.

The requirements associated with the approval of requests to develop infrastructure in the District relate to the expenses associated with this activity. First is the interest to minimize the cost of long-term maintenance required by the District. Second are the costs associated with the execution of these requirements. The Supervisors have determined that all costs associated with development with the District will be the sole responsibility of the property owners desiring to create improvements.

## **Section 2 - Applicability**

The Board of Supervisors have determined that access to all individually owned lots are required to use an improved driveway. All parcels that require a new means of access to or from their individual lots is required to do so utilizing a properly designed and permitted driveway crossing. Parcels which have existing improved driveways can continue to use these existing driveways for means of ingress or egress to the property.

All new roads and driveways must be constructed to the standards adopted by the SCEWCD Board of Supervisors. This includes all forms of access to including construction or maintenance equipment, and motorized vehicles of any kind.

Access to a parcel through an unpaved roadway or side swale is prohibited. Use of the swales, even when they appear dry, leads to degradation of vegetative cover and swale grades which allows erosion to occur that diminishes conveyance capacity of the swale, water quality which is a potential violation of the District MS4 permit with FDEP, damages roadway infrastructure and creates hazards to roadside safety.

Standards are addressed for areas within the District where roadways were not paved for access with the 2005 Capital Improvement Project. (It is important to note that the parcels on unpaved roads pay reduced assessments and only enjoy the benefits for which they are assessed.) The District Supervisors have determined that all parcel owners wishing to develop their property must provide access in accordance with the annually adopted Water Control Plan.

## **Section 3 - Application Requirements**

There are three elements of the District application which must be submitted prior to review. Applicants submitting an incomplete application will be notified as such and the review will not commence until after all elements are complete and are received.

The minimum application requirements include:

### **a) Access Connection and Right of Way Use Permit**

A copy of the current Access Connection and Right of Way Use Permit can be located on the San Carlos Estates Water Control District Website located at the following web address:

<http://scewcd.blogspot.com/>

This application is updated from time to time, so please ensure that the current version, as posted on the District website is utilized. In addition to contractor and property owner phone numbers, please also provide current email addresses.

Applications submitted to the District must be identified as to their intended purpose by checking the appropriate Description Box on the application and further providing any description necessary to convey its intended purpose. Applications that may depict or illustrate improvements that are not specifically identified or noted in the permit application should not be construed as approved by the District. Any such approvals will be explicitly identified within the application section denoted as “Additional conditions of approval (if any)” if they occur.

### **b) Application Fee**

The application fee is specific to the proposed task, there are several possible fee categories identified on the application. All checks should be made out to the “San Carlos Estates Water Control District”. The purpose of these fees is so that the applicants bear the cost of the development of their property.

Fees required at the time of application are considered in the following categories and the amounts are indicated on the application:

- Driveway and Culvert – This choice should be selected where a proposed driveway must cross over an existing roadside swale. At grade swale crossings are not permitted. All swale crossings are required to provide an appropriately sized roadway culvert.
- Driveway Only – In the event that a roadway drainage swale is not present between a roadway and an adjacent lot, a driveway culvert is unnecessary. This mainly occurs along sections of Tuck Drive and the south branch of Stillwell Parkway.
- Roadway Extension – This is required when access to a parcel from a roadway that is unpaved is being requested. Due to the variability of this scope, the permit fee associated with this item requires \$1,500 initial payment. Once the District Engineer has spent 15 hours of time addressing the applicant and application review, additional funds may be required.

Version No 2016-02-15

- Underground Utility Extension-This is a special category normally reserved for Utility Providers such as FPL and Bonita Springs Utilities and is intended primarily for the purpose of evaluating proposed projects through the District that will impact many parcels or large areas of right of way. This category is not normally associated with a simple driveway installation.
- Other Items-The construction of any improvement within a District, dedicated, owned or operated right-of-way is subject to approval by the San Carlos Estates Water Control District. Several examples within this category would include fence construction, the placement of temporary or permanent structures including pools, patios, lanais, sheds or connections of any type to the surface water system.

**c) Site Plan**

A plan showing the proposed improvements must be submitted for review. Specifically, a site plan depicting all proposed improvements within District owned, operated or maintained right-of-way, including any changes in swale grading, culverts, backfill type (limerock, gravel, clean fill, etc.), driveway design type (gravel, limerock, asphalt, concrete, pavers, etc.) with dimensions as appropriate to determine proposed construction impacts to District facilities. Several examples of the site plan are included in Appendix A.

The minimum site plan requirements:

1. Existing adjacent roadway with Roadway Name labeled
2. Property Lines and right-of-way lines, preferably from a survey prepared by a licensed surveyor. Other sources such as the Lee County GIS depict property boundary lines, however, are often inaccurate and should not be the basis for construction activities.
3. Swale Characteristics including but not limited to Top of Slopes, Centerline, etc.
4. Above Ground Utilities including, but not limited to, power poles with guy wires, ground mounted transformers, pull or splice boxes, water/sewer valve boxes and or backflow preventers.
5. Storm drain infrastructure including manholes, inlets, pipes, headwalls or mitered end pipe treatments.
6. Proposed driveway configuration including dimensions from the closest property line, overall widths, driveway surface material type, driveway surface material thicknesses, driveway shoulders, driveway fill slopes.
7. Driveway culvert including culvert diameter, material type, proposed depth of cover and end treatments, if required or provided. Headwalls are not permitted as an end treatment generally because the roadside swale is within the roadside clear zone and non-frangible vertical elements greater than 4" in height are a roadside hazard.
8. All final slopes and grades. No final slope shall be steeper than three feet horizontal for every one foot vertical (3H:1V).
9. Erosion Protection – show silt fence installation through the adjacent roadside swale from top of bank to top of bank at all side lot lines and across the lot frontage at the right of way . The intent is to isolate district swales from potential sedimentation caused by

unstabilized construction areas as a result of driveway construction or construction within the adjacent lot.

**10. Required Notes – the following notes must be included on the Site Plan for the benefit of the contractor installing all proposed improvements:**

**Erosion Control Notes:**

- a. Erosion controls are required on this project prior to any site clearing or grubbing when stormwater runoff can convey sediments to any part of the SCEWCD Stormwater Management System.
- b. Erosion controls BMPs are not limited to installation of silt fence in and along the adjacent swale(s). Site conditions may require the Contractor to install additional BMPs at the sole discretion of the District Engineer as he or his designee determines is needed as reasonable to prevent damage to the SCEWCD Stormwater Management System.
- c. Contractor is responsible to maintain all erosion controls at ALL times during construction until the project has been stabilized. No exceptions are permitted.
- d. Contractor will remove any soil tracked from the project site by construction vehicles. This may require daily removal of all stray material. Proper removal is considered to be returning tracked soils to the project site and does not include sweeping or washing them in to a District swale or drain.
- e. Failure to maintain erosion controls may cause damage to the stormwater management system of the SCEWCD. Contractor and property owner are responsible to repair all damage immediately as prescribed by the District Engineer. The contractor understands that the District Engineer will report all erosion control failures to Lee County Division of Natural Resources and Bonita Springs Code Enforcement. In the event the District Engineer has determined the permittee has allowed the erosion controls to fail and does not repair them immediately, the District Engineer is not permitted to allow ANY exceptions to this protocol.

**d) Approved Permit and Commencement of Work**

Approved permits will expire following three (3) years from the date of approval OR one (1) year from the date of commencement, whichever occurs first, as indicated on the Notice of Commencement which is required to be submitted to the District Engineer at least 48 hours prior to the start of ANY work on the parcel.

The Notice of Commencement is attached to the permit application form available for download from the District's website.

## **Section 4 - Driveway Standards**

### **4.1 Typical Installations**

A typical driveway installation within the District consists of a single driveway being constructed through a roadway swale. A culvert crossing under the driveway for continued drainage of the roadside swale is necessary in this case, but there are locations where culvert are not required. The District Engineer can issue a construction permit for up to two (2) driveway connections per lot. No driveway may be greater than 30 feet in width or less than 20 feet in width. The 20 foot minimum width restriction only affects that portion of the driveway within the District right-of-way and the entire 20-foot width does not have to be paved. Instead, a portion of the 20-foot width can be placed at or slightly below the elevation of the main driveway surface. A roadway swale may not be converted into a completely piped drainage system.

### **4.2 Driveway Materials**

Materials used to create the final driveway surface should conform to Table 4.2.B. Other driveway materials may be utilized, however they will need to be approved on a case by case basis. If a driveway material to be installed in a District Easement or Right-of Way other than those indicated in Table 4.2.B is desired, the application must include relevant details and cut sheets for the final proposed surface, which will be subject to approval by the District Engineer.

**TABLE 4.2.B**

<b>MATERIAL TYPE</b>	<b>MINIMUM REQUIREMENTS</b>
Concrete apron	6" thickness; 3,000 psi (must show proof of mix design)
Sand set brick pavers	Use manufactures recommended installation procedures; must be rated for traffic loading and installed per manufacturers recommendations for traffic loading applications
Asphalt	Single 1" lift of Type S-1 Marshall mix on a 4" limerock base as defined and installed per FDOT Specifications for Road and Bridge Construction 2000 Edition.
Gravel surface	6" thickness of no. 57 stone or equivalent gravel material
Compacted limerock	6" compacted thickness of limerock base material meeting material requirements and installation standards of the FDOT Specifications for Road and Bridge Construction 2000 Edition.
Turf block paver	Use manufactures recommended installation procedures; must be rated for traffic loading and installed per manufacturers recommendations for traffic loading applications

APPLICANT or CONTRACTOR SHALL INDICATE MATERIAL FOR USE IN DRIVEWAY CONSTRUCTION ALONG WITH THE COMPLETED DRIVEWAY APPLICATION.

### 4.3 Drainage Considerations

In addition to providing simple access to and from an existing lot, construction of the driveway may not negatively impact swale drainage. During the rainy season, it is not uncommon for all of the swales in the District to have standing water for an extended period of time. This coupled with the fact that it is not unusual for the District to experience several inches of rain in a single day, with a recently recorded high of 8 inches during a single day, places great emphasis on the sizing, construction and maintenance of the drainage system within the District. The drainage system within the San Carlos Estates Water Control District was designed and installed along with a Capital Improvements project that took place around 2005.

During the drainage design for the CIP, the system was determined to require the piped driveway culvert capacity of an 18" pipe for all future driveways, with the exception of driveways occurring along Strike Lane. As much of the flow developed north of Strike Lane drains towards the Strike Lane right-of-way, where it concentrates and is conveyed west towards a series of ponds along Strike Lane, a much greater pipe capacity is required, equivalent to two 19"x30" elliptical pipes for all driveway installations North of Strike Lane and east of Rodas Drive. Similarly, some of the flow from side streets south of Strike Lane is directed to the Strike Lane Roadway swale where it is conveyed west towards a treatment wetland area. As a result, the capacity of culverts along the south side of Strike Lane up to Stillwell Road was determined to be equivalent to a single 19"x30" elliptical pipe. Culvert crossings south of Strike Lane east of Stillwell Road require the standard 18" pipe equivalent. The following table, which is also contained within the permit application provides a summary of these pipe sizing requirements.

**TABLE 4.3.A**

LOCATION	CULVERT SIZE
Connections to north side of Strike Lane	(2) 19" x 30" RCP Only
Connections to south side of Strike Lane from Tuck Drive to Stillwell Parkway	19" x 30" RCP Only
Connections to south side of Strike Lane east of Stillwell Parkway	18"
All other north – south streets except Stillwell Parkway south of Strike Lane	18"
Stillwell Parkway south of Strike Lane Strike Lane west of Rodas Drive Bonita Bill Drive (All) Moriah Drive (All) Tuck Drive (All)	No culvert required <u>unless</u> driveway will cross existing roadside swale or if District Engineer determines runoff would be obstructed by proposed improvements

There is some opportunity to substitute different types of pipes within the District swale system based on providing an equivalent or better pipe area. In some cases a substitution may aid in achieving the required amount of cover between the pipe and the overlying driveway surface. The best example of this is the substitution of an 18" pipe with an elliptical equivalent 14"x23" ERCP. Equal area pipe substitutions are



permissible as long as they can be made within the foot print of the existing swale bottom. If the swale bottom would need to be widened to accommodate a proposed pipe configuration, such configuration cannot be approved. Note that 24" pipe cannot be used in lieu of a 19"x30" elliptical pipe in swales located on Strike Lane due to hydraulic design constraints.

#### 4.4 Pipe Material

Approved driveway culvert material includes:

1. Class III concrete pipe
2. HDPE pipe meeting the requirements of the FDOT Road and Bridge Constructions for a "Class II HDPE Pipe".

**NOTE:**

When HDPE pipe is utilized for driveway construction, provide the District Engineer a copy of pipe product specifications demonstrating said material conforms to the Class II HDPE Pipe requirements. **Note that any driveway utilizing an HDPE pipe must provide at least one foot (1-foot) of filled cover over the pipe and the fill must be compacted to at least 98% of the AASHTO T-180 modified proctor test.** A signed and sealed compaction report demonstrating an adequate compaction effort must be provided prior to final driveway closeouts and certifications. It is strongly encouraged that a satisfactory compaction report be acquired prior to request of any final driveway surface. Final construction for a driveway will not be accepted by the District Engineer without a satisfactory compaction test even if the finished driveway surface is installed. The District Engineer may require removal of the surface material for additional compaction until a satisfactory test report can be provided.

#### 4.5 Depth of Cover Concerns

Swale depths within the District can vary with natural ground elevations occurring within the adjacent existing lot. When installing a culvert crossing the Contractor must acknowledge final lot and driveway grading and elevations. Careful consideration of pipe diameter, material type including pipe cover need to be made before installation to ensure the ultimate elevations and driveway grading are consistent with the overall elevations and grading of the proposed finished lot and home site. The District Engineer will not accept substandard installation except as authorized by the Supervisors.

The ideal installation includes a properly sized culvert along with its prescribed minimum cover depth and final driveway surface would all be able to occur within the existing depth offered by the swale. In consideration of actual application of the design requirements, it is often the case that an 18" HDPE pipe is selected based on overall pricing considerations. This common alternate, however, requires a cover depth of at least 30". Instead, an elliptical 14"x23" concrete pipe alternative, which requires a cover depth of at least 8" would often be a more suitable alternative with respect to field conditions as it requires less depth for installation with a minimum required depth of 24.75" for installation.

In the event that cover cannot be achieved for an HDPE pipe alternate using normal grading techniques, a more creative approach to grading will be required. One successful approach to grading in the past has resulted in the creation of a vertical hump in the location of the pipe. Although this configuration would meet the material design requirements for the pipe installation, it is often undesirable on the part of the homeowner. A second creative approach is to increase the final grade of the driveway closest to the right of way line, so that the fill within the vicinity of the pipe meets the 12" requirement. Sumped construction of the pipe so that it is slightly lower than the existing swale grade, up to 3" max, is allowable. Sump depths greater than 3" are not permitted because it will require increased maintenance costs to the District.

#### **4.6 Pipe End Treatment**

The 19"x30" ERCP pipes along Strike Lane are required to be fitted with a 4:1 sloped (horizontal to vertical) concrete mitered end section along both pipe ends. Relevant details for the mitered end section are found in Appendix B. Other driveway culverts are not required to have end treatments, however, they may, if desired by supplied with appropriately sized mitered end sections. No headwalls or other non-frangible vertical wall or obstruction may be placed along the pipe ends or within any other part of the District right-of-way as such is within the roadway clear zone and would constitute a roadside hazard in concurrence with current roadway design standards. Although there are several locations throughout the District where these improvements may exist, they were constructed prior to implementation of this policy and are no longer accepted by the Supervisors.

#### **4.7 Temporary Driveway Construction**

After approval of the completed application, a temporary culvert crossing may be constructed to access the site in lieu of initial installation of the approved culvert crossing. The most common reason for this includes the desire to protect the final culvert crossing and or driveway from damage related to construction activities. A second common reason is to shorten the timeframe to establishing access to the site so construction activities can commence. A temporary driveway crossing into the lot is allowed to occur at any point within the swale in front of the subject lot. Temporary construction driveways are subject to the following restrictions:

- 1) Minimum pipe crossing size, when accessing lots not adjoining Strike lane is 12".
- 2) For lots adjoining Strike Lane which require a permitted pipe size of 19"x30", a smaller construction pipe size is not permissible, the permitted pipe size must be utilized.
- 3) Temporary driveway widths are limited to a maximum width of 20'.
- 4) There is no minimum fill requirement over pipes to be temporarily used as a construction entrance, provided these same pipes will not also be used in the permanent driveway installation.
- 5) The contractor is required to keep the pipes and swale completely free of sediment and debris until final site stabilization is achieved.
- 6) In the event of that the site is within the 3-day cone of uncertainty of a hurricane, any temporary driveway installation not implementing the permitted pipe size shall be removed

and the swale restored to its previous grade within 24 hours. In the event the contractor fails to act, the District shall reserve the right to restore the swale system in advance of the natural disaster and the contractor will be charged for any related costs.

- 7) If the temporary driveway is the cause of upstream flooding, it will be removed, until the flooding has subsided.
- 8) A temporary driveway may not be installed until the required silt fence and or any other necessary erosion controls have been installed.

## **Section 5 - Unpaved Roadways**

In the event that a property having no access to a paved roadway section is proposed for development, in addition to driveway and culvert installation, the owner is required to extend a paved roadway from the closest paved roadway location up to their proposed driveway entrance. The required typical section is based on the location of the roadway and is found in Appendix C. The District Engineer will specify the required roadway crown elevation which will match the road crown adjacent to the proposed road location. In addition to normal driveway permitting, the Owner's responsibility includes, but is not limited to:

- 1) Development of adequate engineering plans and engineering documentation for development, review and construction of the proposed roadway extension.
- 2) Obtaining all necessary federal, state or local permits for construction.
- 3) Construction of said improvements.
- 4) Responsibility to comply with all Federal State and Local Laws including being responsible for and paying any fines or punishment as a result of not meeting such rules or regulations.
- 5) Construction Inspection as is traditional for roadway construction to prove compliance with all applicable agencies rules and requirements.
- 6) Assembly of As-Built Documentation.
- 7) All related fees.

Several typical sections have been developed in the past for use in several locations and are included within Appendix C. Properties along Bonita Bill Drive will need to utilize the cross section titled "Bonita Bill Typical Section". All other locations will need to use the typical section titled "All Other Side Streets".

It should be noted that this type of construction is atypical and as such may incur additional permit / inspection / review and permit extension fees and conditions as indicated in Section 3.

## **Section 6 - Temporary Erosion Control Requirements**

The minimum standards contained herein are not all-encompassing for any construction project. This section deals solely with property owned or controlled by the District, other permitting agencies may have additional requirements for their areas of authority.

All erosion control devices must be installed prior to any site disturbance including clearing and grubbing, or permanent or temporary driveway construction. Erosion control devices must remain in place until final construction approval of the driveway is obtained, or until the site is determined by the District Engineer as being stabilized. Stabilization is defined as being to the point where all exposed ground within the District right of way and within the adjacent lot subject to construction will no longer be prone to convey sediments in stormwater runoff (turbidity) due to erosion of soils disturbed by construction activities.

**The minimum erosion controls required by the District include a continuous section of silt fence to be placed through the swale at each property line from top of bank to top of bank and along the road right of way across the lot frontage.**

Erosion controls are not limited to installation of silt fence in and along the adjacent right of way frontage. Site conditions may require the Contractor to install additional BMPs at the sole discretion of the District Engineer as he or his designee determines is needed as reasonable to prevent damage to the SCEWCD Stormwater Management System.

Contractor is responsible to maintain all erosion controls at ALL times during construction until the project has been stabilized. No exceptions are permitted. The contractor is free to install additional erosion controls if they determine the minimum specifications are not sufficient to control turbidity.

Failure to maintain erosion controls may cause damage to the stormwater management system of the SCEWCD. Contractor and property owner are responsible to repair all damage immediately as prescribed by the District Engineer. The contractor understands that the District Engineer will report all erosion control failures to Lee County Division of Natural Resources and Bonita Springs Code Enforcement. There are no exceptions to this protocol.

In a typical installation two (2) single sections of silt fence installed along the north property line and another being installed along the south property line. The silt fence would then run perpendicular to the swale from the top of bank on one side of the swale to the opposite top of bank.

The same principle applies for properties along Strike Lane except it would relate to east and west property lines instead of north and south property lines. At corner lots, or in locations where other drainage devices may exist, such as ditch bottom inlets or cross drain pipes under intersecting roadways, additional silt fence must be staked around structures encountered with the adjacent swale in such a fashion as to prevent transport of unfiltered sediment to any offsite location. See Appendix A for approximate silt fence locations.

For streets where no swale exists, such as along Tuck Drive or the south leg of Stillwell Parkway, and a shoulder gutter is used instead, at a minimum rock bags or hay bales will need to be placed in the shoulder gutter so as to prevent sediment from running through the gutter and washing into an adjacent canal or piped system. In the event that hay bales or rock bags are insufficient for this purpose, due to level of construction activity, the owner may be required to run silt fence along the back of gutter along the lot line, turning at a 90 degree angle at the end of construction and running a section of silt fence into an upland area within his lot.

The contractor will remove any soil tracked from the project site by construction vehicles. This may require daily removal of this stray material. Proper removal is considered to be returning tracked soils to the project site and does not include sweeping or washing them in to a District swale or drain.

The contractor is required to remove any and all temporary erosion control devices at the end of all construction related activities after final groundcover is established within both the roadway swale and the adjacent lot.

## **Section 7 - Construction Material Specifications**

In general all pipes, backfill (including pipe cover) material and compaction test requirements must meet the specifications contained within the current edition of the FDOT "Specifications for Road and Bridge Construction". Excerpts from these specifications are contained within Appendix D.

Pipe material may be Class III or better Concrete Reinforced Pipe (RCP) or High Density Poly Ethylene (HDPE) Class II as recognized by the Florida Department of Transportation. Aluminum culverts are not permitted for use as a culvert material due to its need for replacement every 15 to 20 years. Other traffic load rated piping materials may be considered on a case by case basis. If a different type of pipe is proposed for construction, please submit relevant manufacture data as is sufficient to identify and analyze the proposed material. Atypical pipe materials may require more than 12" of cover.

A coarse rock or stone backfill will not be permitted as backfill around the driveway culvert because it would result in piping of stormwater through the backfill material and eventual erosion of the overlying driveway. Instead the applicant shall use a material compliant with the FDOT specifications suitable for use in roadway embankment as contained within Appendix D.

## **Section 8 - Monitoring Submittals and Requirements**

There are several types of monitoring that occur during the life of the construction project. Monthly construction monitoring occur automatically every month during the life of the project. The Pre-Backfill Inspection and Final Certification Inspection are two mile stone inspections that are required prior to progressing into certain phases of construction. The contractor is required to notify the Engineer when either Inspection is warranted. The District Engineer will have up to two (2) business days to have a representative onsite to perform said site visit unless other arrangements are made at the time of the request.

### **8.1 Monthly Construction Monitoring**

Monthly site visits are intended to ensure general compliance with District erosion control requirements, general policies, to check for damage to District owned facilities and to evaluate the ability of the swale to convey stormwater. The District Engineer or his designee are not necessarily concerned with disturbed versus undisturbed areas as long as the required erosion controls are being maintained. The contractor

will not be notified as to when monitoring will occur as such are intended to evaluate daily compliance with District policies. This activity is in no way to be construed or implied as warranting the Contractor's work by the District.

## **8.2 Pre-Backfill Check**

The pre backfill check are intended to coincide with the placement of the permitted driveway culvert. It takes place after:

1. the contractor has installed the required temporary erosion controls
2. physically placed the driveway culvert in its intended position within the roadside swale
3. prior to placement of backfill of any type

A pre-backfill check is intended to verify the layout, diameter, material type, proper jointing of any segmented pipe, and general configuration of the permanent driveway culvert, with respect to the approved permit prior to backfill. This is the point in time where many corrections can be noted and implemented without costing the contractor or owner a lot of time or money. No fill may be added until this check occurs, as any fill will obscure any pipe connection or the physical condition of the pipe. If any backfill or final surface is placed prior to this time, the District Engineer will not acknowledge compliance until it is removed and the pipe exposed for direct observation.

Temporary culvert crossings are not required to receive a pre-backfill inspection, however, the contractor is required to notify the engineer whenever a temporary driveway is installed. Pipes used in temporary culvert crossings may not be used as a part of final construction.

## **8.3 Final Certification**

A final certification inspection is required at the end of driveway and driveway culvert construction. The final certification inspection will compare the permitted driveway configuration to its installed condition. Deviations to the permitted condition may be allowed to the effect that such deviations would have been approved via permit process.

This inspection will generally look for but is not limited verification of the following items:

- 1) Depth of cover over the pipe. Any configuration failing the required depth of cover must be corrected, which may require the removal of any final driveway surface placed.
- 2) Final slope within District owned right-of-way - may exceed 3:1 (H:V).
- 3) Stabilization of ALL disturbed surfaces which may have occurred during construction.
- 4) Pipe diameter.
- 5) Ensure that the culvert is installed in a straight line and grade, HDPE pipe which is deformed at the time of inspection, or which loses its physical alignment during compaction is installed incorrectly and will need to be replaced.
- 6) Ensure that any damage to district owned facilities is adequately repaired.
- 7) If an HDPE pipe is utilized during construction, final compaction reports, signed and sealed by a registered geotechnical engineer indicating a compaction of at least 95% for the pipe backfill must be provided prior to final certifications. Compaction not meeting at least 95% will not be considered adequate for driveway construction and the resulting backfill compaction will need to

be corrected. It is highly recommended that compaction be evaluated by the contractor prior to placing a final driveway surface as it may result in the driveway surface needing to be removed to achieve proper compaction.

The contractor or owner may utilize any Geotechnical Engineer registered in the State of Florida for providing of compaction tests.

If the condition of the improvements are such that the driveway construction can receive final clearance, and all other site related construction is completed and finally stabilized then temporary erosion controls may be removed. If any deficiency is identified, it must be corrected prior to receiving final construction clearance. If such deficiency is great enough, it will require significant additional construction related effort. An additional Final Certification Inspection will be required at which time the contractor will also be required to pay the related additional fee as noted in the "Driveway Connection and ROW Use Permit Form" for additional inspections. If the adjacent site is still undergoing construction such that any adjacent lands will become disturbed in the future, the contractor is required to maintain all temporary erosion devices.

## **Section 9 - Compliance and Enforcement Actions**

### **9.1 Unpermitted Activities**

As a result of past experience with respect to typical contractor actions that have resulted in enforcement action, the following list has been assembled in an effort to notify the contractor of activities that are not permitted within the District right-of-way.

- 1) Access to the site is permitted via temporary construction driveway or permanent driveway only. The roadside swale may not be used for site ingress/egress.
- 2) District right-of-way, including the swale and overlying driveway may not be used for material storage, equipment storage or any other construction related use.
- 3) If any dewatering activity is required and any District facility is desired to be utilized as an outfall the District Engineer must be notified prior to use unless previously permitted at (239) 337-3993 and the contractor may be subject to additional conditions and requirements related to dewatering efforts at the sole discretion of the District Engineer.
- 4) Parking of vehicles or equipment may not occur within the roadway shoulder or swale.
- 5) The contractor is required to repair any damage incurred by the contractor to all district related facilities prior to final inspection. Performance of any corrective repairs is a precondition to Final Construction Certification.
- 6) No ornamental landscaping plants or materials of any type shall be placed within the roadside swale or roadway shoulder. The only landscaping material allowed within these locations is sod.
- 7) All Erosion device shall be properly installed and maintained throughout the entire construction process.
- 8) Tracking of dirt on District Roadways is not permitted. The contractor is required to remove any dirt accumulated on the roadway surface as a result of construction activities. It is recommended that the contractor install a stabilized construction entrance to cut down on the amount of soil

tracked onto adjacent roadways. A suggested stabilized entrance design is provided in Appendix B.

- 9) Spills related to anything other than water shall be treated as noted in Appendix E "Spill Reporting Procedures".



APPENDIX A  
Site Plan Examples

PROJECT:

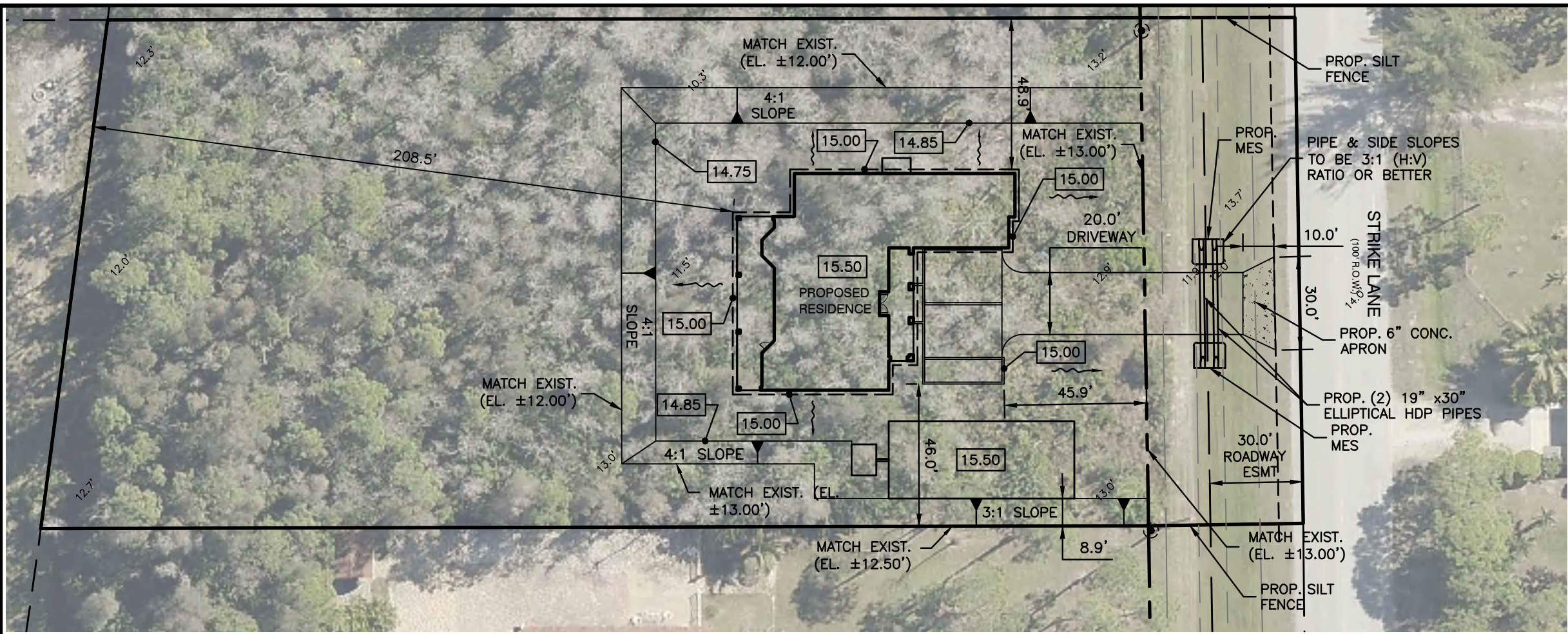

FOR EXAMPLE PURPOSES ONLY  
 ACTUAL CONDITIONS MAY BE DIFFERENT  
 AND NECESSITATE A DIFFERENT DESIGN.  
 CONSULT THE ACCESS STANDARDS  
 HANDBOOK FOR SPECIFIC DETAILS

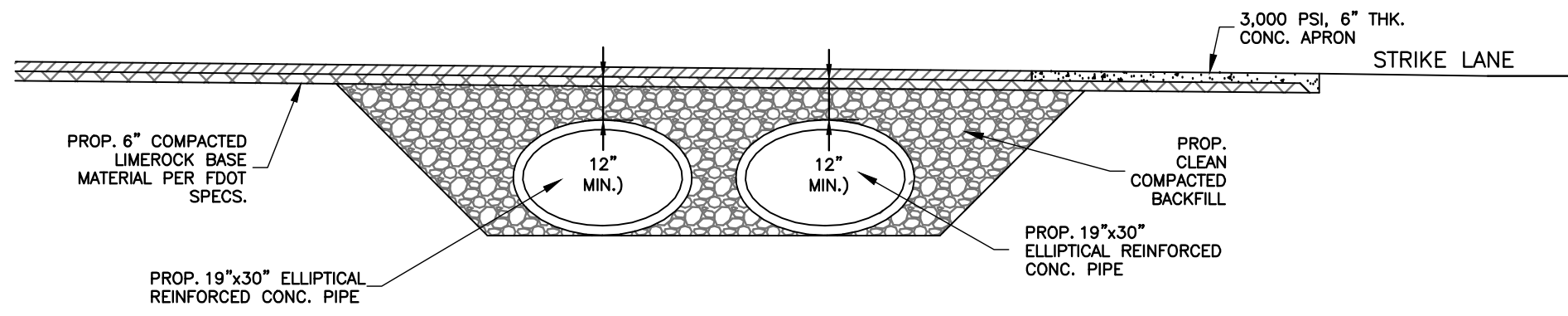
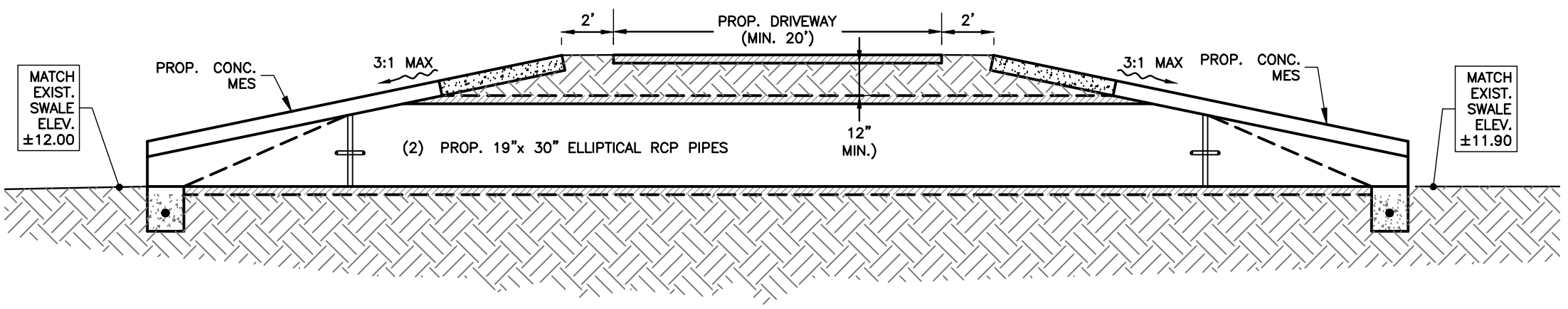

- GENERAL NOTES
1. DRIVEWAY & APRON TO BE 3,000 PSI CONCRETE, A MINIMUM THICKNESS OF 6" AT APRON.
  2. TYPE III SILT FENCE TO BE INSTALLED & MAINTAINED IN ROADSIDE SWALE @ INTERSECTING PROPERTY LINES AS SHOWN.
  3. ALL BACKFILL PLACED & COMPACTED PER FDOT SPECIFICATIONS FOR ROAD & BRIDGE CONSTRUCTION.
  4. ALL TEMPORARY EROSION CONTROL DEVICES WILL BE REMOVED UPON RECEIPT OF FINAL INSPECTION APPROVALS.
  5. ALL DISTURBED UNPAVED AREAS SHALL BE PROPERLY SODDED SUCH THAT EROSION DOES NOT OCCUR.

5/13/2015 G:\15038 - La Florida Model Grading Plan - Lot 10171 Strike Lane\DWG\Current Design\Engineering Design\Plan Sheets\15038 Sheet C-3.01 Site & Grading Plan.dwg

FOR EXAMPLE PURPOSES ONLY  
ACTUAL CONDITIONS MAY BE DIFFERENT  
AND NECESSITATE A DIFFERENT DESIGN.  
CONSULT THE ACCESS STANDARDS  
HANDBOOK FOR SPECIFIC DETAILS

151

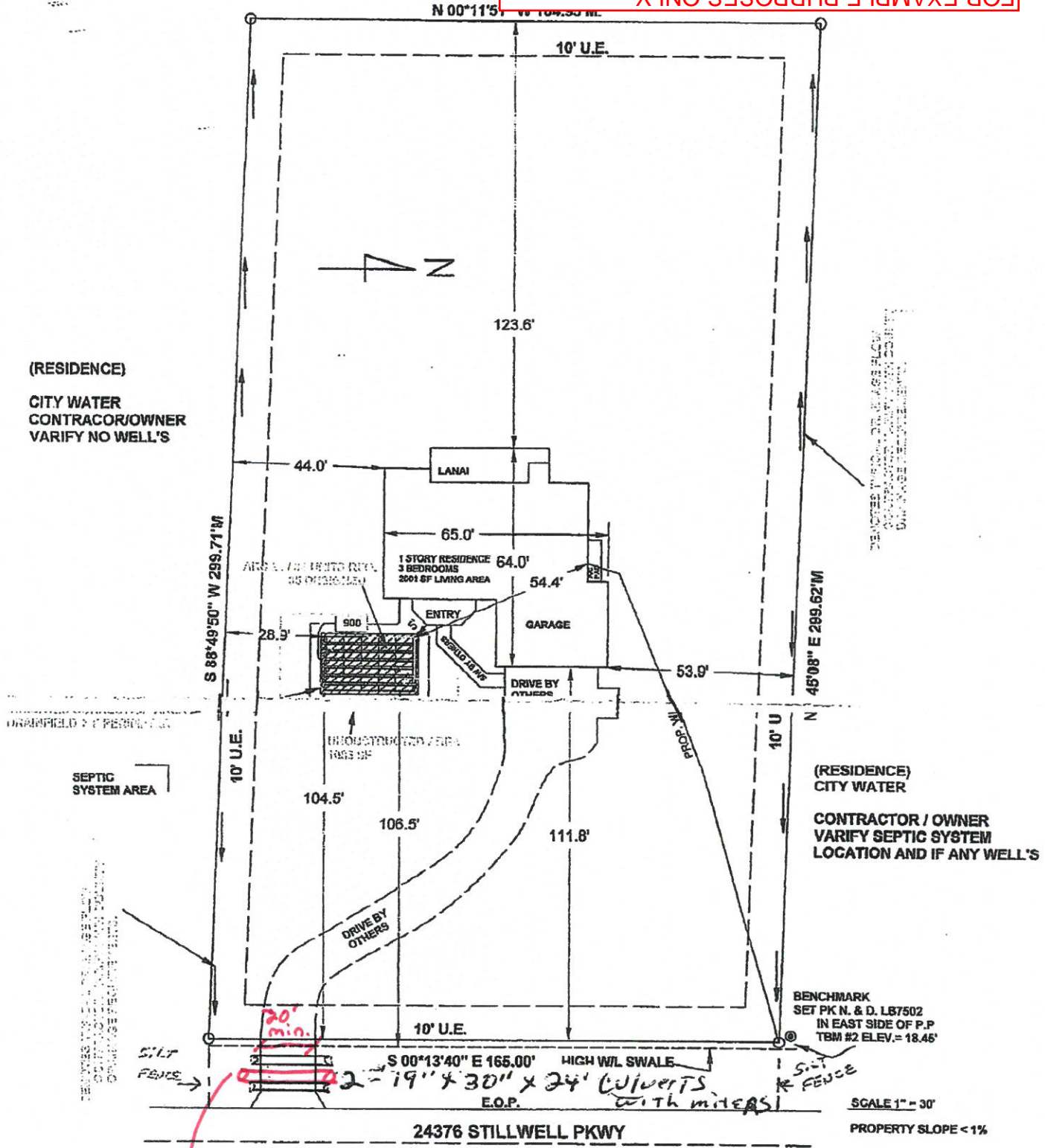

(RESIDENCE)  
CITY WATER  
CONTRACOR/OWNER  
VARIFY NO WELL'S

(RESIDENCE)  
CITY WATER  
CONTRACTOR / OWNER  
VARIFY SEPTIC SYSTEM  
LOCATION AND IF ANY WELL'S

S 88°49'50" W 299.71' M  
10' U.E.  
104.5'  
106.5'  
111.8'  
10' U.E.  
S 00°13'40" E 165.00'  
HIGH W/L SWALE  
E.O.P.

BENCHMARK  
SET PK N. & D. LB7502  
IN EAST SIDE OF P.P.  
TBM #2 ELEV. = 18.45'

SCALE 1" = 30'  
PROPERTY SLOPE < 1%  
TRACT 383  
STRAP# 15-47-25-B2-00200.3830

Single 18" Culvert, Concrete

FOR EXAMPLE PURPOSES ONLY  
 ACTUAL CONDITIONS MAY BE DIFFERENT  
 AND NECESSITATE A DIFFERENT DESIGN.  
 CONSULT THE ACCESS STANDARDS  
 HANDBOOK FOR SPECIFIC DETAILS

**PEST / DECAY PROTECTION NOTES:**

- ALL PLANTINGS AND IRRIGATION/SPRINKLER SYSTEMS, INCLUDING ALL RISERS AND SPRAY HEADS SHALL BE AT LEAST 1 FOOT FROM BUILDING WALLS
- SOIL TREATMENT SHALL MEET THE REQUIREMENTS OF THE 2001 F.B.C. 806 BUILDER TO SUBMIT A COPY OF PROTECTION INFORMATION FOR COUNTY APPROVAL PRIOR TO INSTALLATION
- WOOD GRADE STAKES SHALL NOT BE USED
- PROTECTION AGAINST DECAY AND TERMITES SHALL BE PROVIDED IN ACCORDANCE WITH THE 2001 F.B.C. 805.4.4.
- ROOF FLASHINGS SHALL BE PROVIDED IN ACCORDANCE WITH THE REQUIREMENTS OF THE 2001 F.B.C. 9-092.1
- CONCRETE / ROOF DOWNSPOUTS WILL DISCHARGE A MINIMUM OF ONE FOOT FROM BUILDING WALLS.

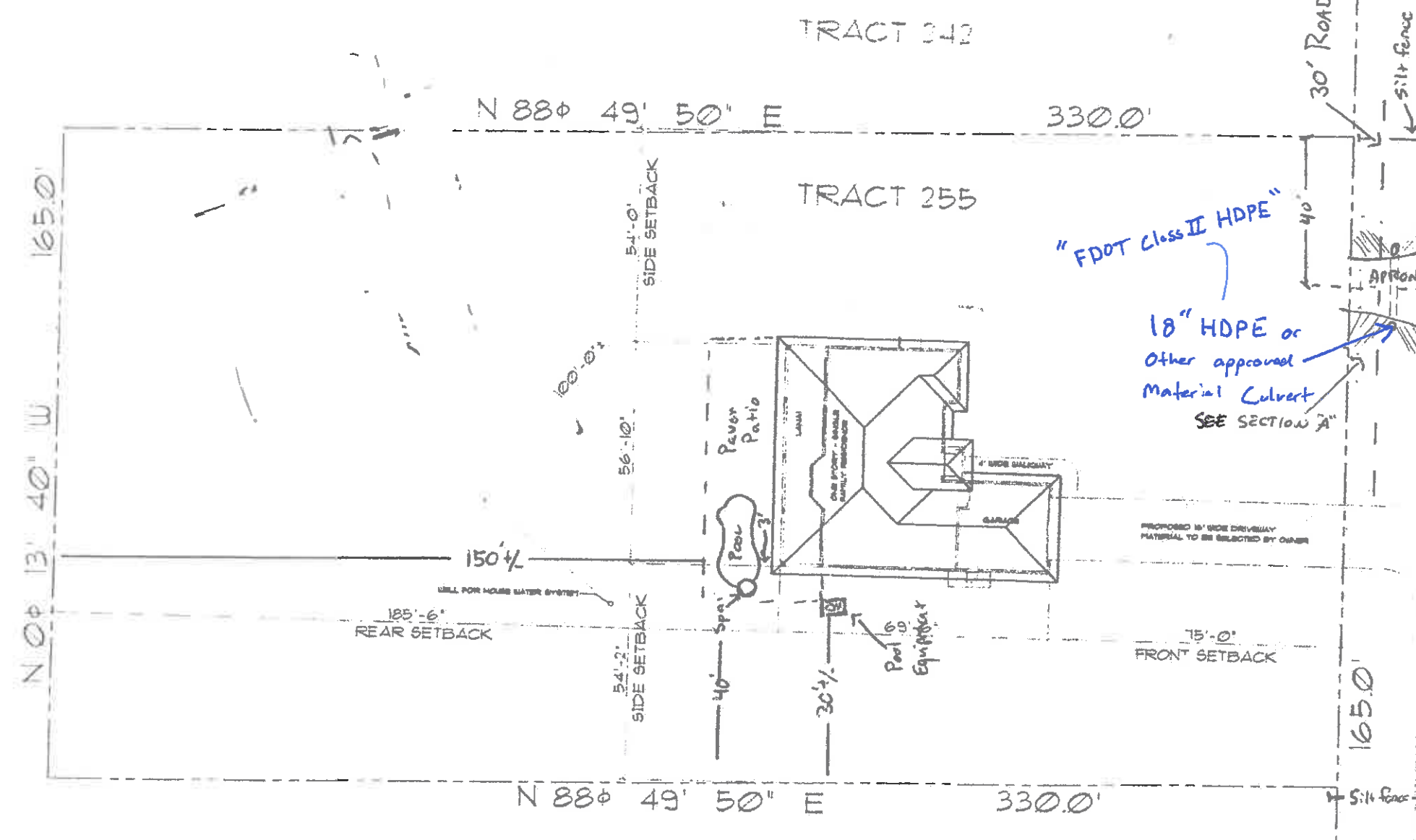

- Apron to be gravel with minimum 6" thickness all fill material to be properly compacted and tested
- Type III silt fence to be installed & maintained in roadside swale @ intersecting property lines as noted.
- All backfill placed and compacted per FDOT specifications for road & bridge construction
- All temporary erosion control devices will be removed upon receipt of final inspection approvals
- All unpaved areas @ apron area shall be properly sodded such that erosion does not occur

Notes:

- IF using Class II HDPE Please note the required Compaction test per item 16 within the Rules & Reg. Section of the permit App.
- Compaction test must be performed prior to placing final driveway surface.
- Driveway width of 20' is required and must be maintained through entire 30' Road Easement.

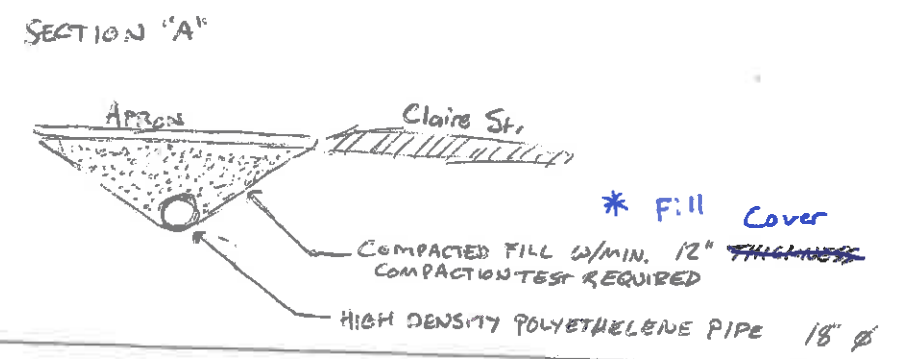

SITE PLAN SCALE 1/8" = 1'

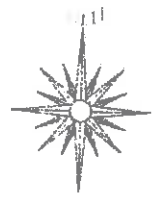

**LEGAL DESCRIPTION**  
 TRACT 255 SAN CARLOS ESTATES  
 OR BOOK 891, PAGES 304 & 305  
 LEE COUNTY, FLORIDA  
 SECT 14 TWP 41 S RANGE 23 E

**COMPLIANCE STATEMENT**  
 THIS BUILDING STRUCTURE HAS BEEN DESIGNED IN ACCORDANCE WITH THE 2004 EDITION OF THE FLORIDA BUILDING CODE WITH FBC 2006 AMENDMENTS SECTION 1609 FOR THE DESIGN PRESSURE GENERATED BY A DESIGN WIND VELOCITY OF 150 MPH. GRAVITY LOADS WERE TAKEN INTO ACCOUNT DURING THE DESIGN PROCESS OF THIS PROJECT. WIND IMPORTANCE FACTOR IS '1.0' AND EXPOSURE IS 'B'. INTERNAL PRESSURE COEFFICIENT = 0.0

WHEREAS EVERY ATTEMPT HAS BEEN MADE TO INCLUDE ALL DETAILS AND PERMIT INFORMATION ON THE DRAWING CONTRACTORS ARE RESPONSIBLE TO VERIFY ALL DIMENSIONS, DETAILS, AND INFORMATION PROVIDED ON THE DRAWING. CONTRACTORS SHALL NOTIFY THE DESIGNER IMMEDIATELY IN WRITING FOR ANY OMISSIONS OR DISCREPANCY ON THE DRAWING PRIOR TO THE START OF ANY WORK.

PRELIMINARY   
 CONSTRUCTION   
 FINAL RECORD

DATE 03-15-07

DESIGNER

SHEET NO  
**SITE**  
 07-008

SCALE 1" = 36'

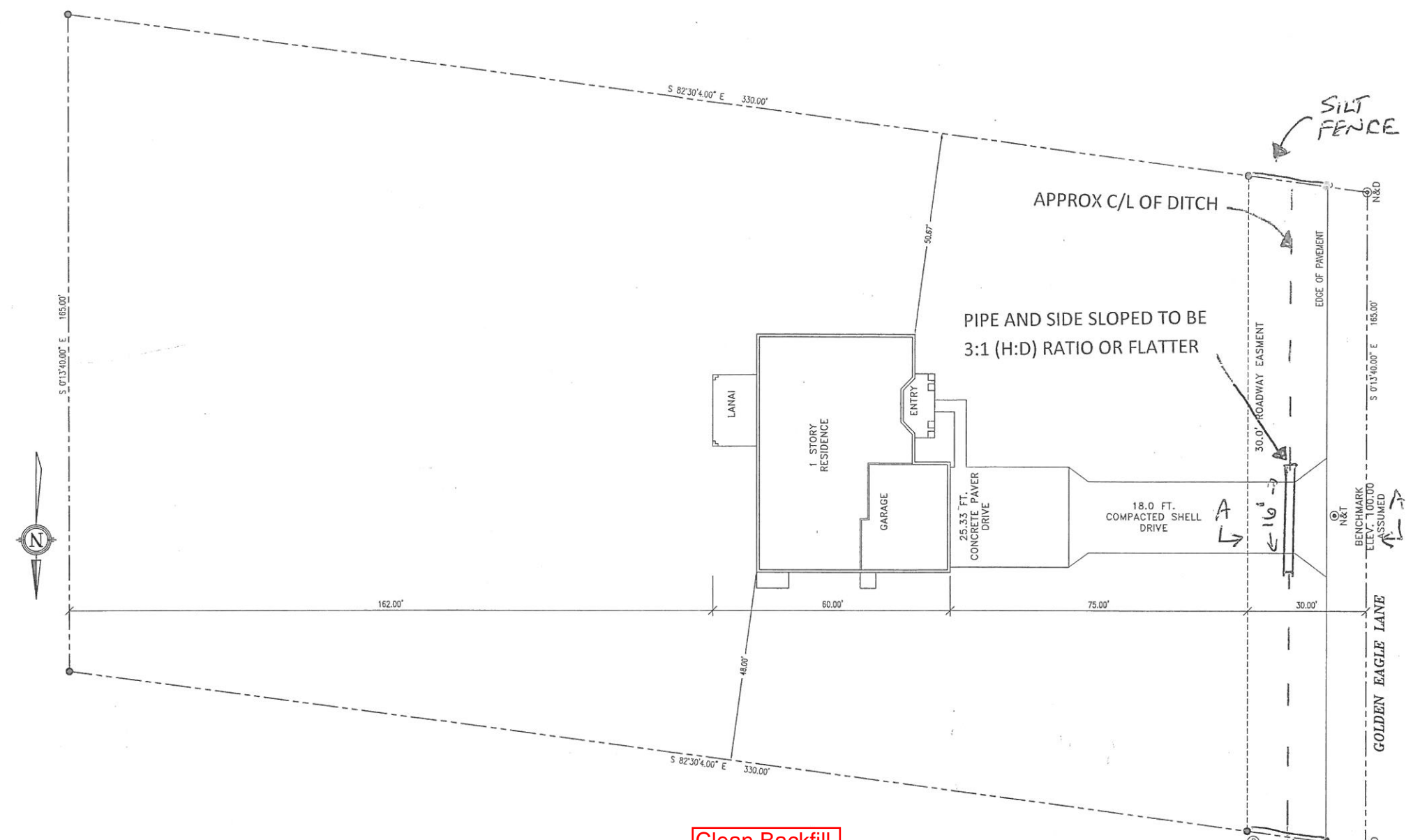

- NOTES:**
- 1) DRIVEWAY AND APRON TO BE 3,000 PSI CONCRETE, A MIN OF 6" THICKNESS @ APRON
  - 2) TYPE III SILT FENCE TO BE INSTALLED & MAINTAINED IN ROADSIDE SWALE AND INTERSECTING PROPERTY LINES AS NOTED
  - 3) ALL FILL & BACKFILL PLACED & COMPACTED PER FDOT SPECS FOR ROAD CONSTRUCTION
  - 4) ALL TEMPORARY EROSION CONTROL DEVICES WILL BE REMOVED UPON RECEIPT OF FINAL INSPECTION APPROVALS
  - 5) ALL UNPAVED AREAS & APRONS AREA SHALL BE PROPERLY SUCH EROSION DOES NOT OCCUR

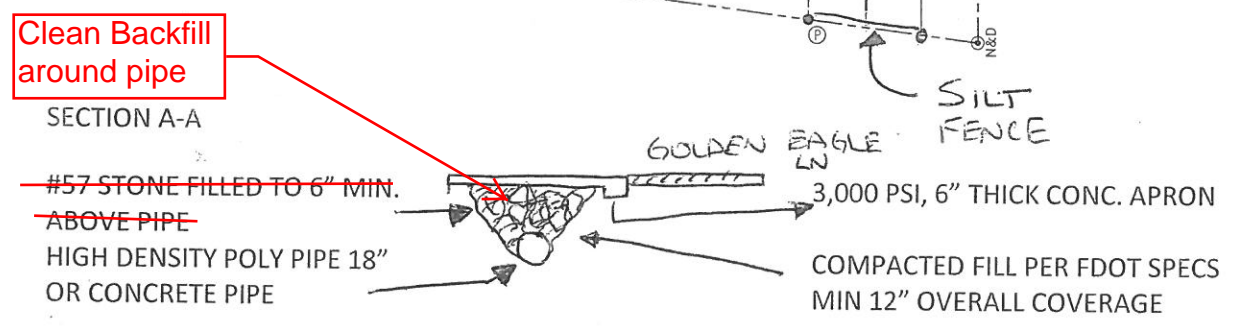

THIS DRAINAGE PLAN USES A PRELIMINARY FINISH FLOOR ELEVATION. INFORMATION USED TO CALCULATE CONSTRUCTION CERTIFICATION BY A PROFESSIONAL ENGINEER MAY BE REQUIRED IN THE FUTURE. DESIGN AND CONSTRUCTION SHOULD NOT BE DEPENDENT ON THE ACTUAL FINISH FLOOR ELEVATION. THE USER SHOULD VERIFY ALL DIMENSIONS, ELEVATIONS, AND CONDITIONS PRIOR TO CONSTRUCTION FOR THE PROPERTY LISTED ABOVE.

SITE PLAN

SCALE 1" = 20'-0"

FOR EXAMPLE PURPOSES ONLY  
 ACTUAL CONDITIONS MAY BE DIFFERENT  
 AND NECESSITATE A DIFFERENT DESIGN.  
 CONSULT THE ACCESS STANDARDS  
 HANDBOOK FOR SPECIFIC DETAILS

FOR EXAMPLE PURPOSES ONLY  
 ACTUAL CONDITIONS MAY BE DIFFERENT  
 AND NECESSITATE A DIFFERENT DESIGN.  
 CONSULT THE ACCESS STANDARDS  
 HANDBOOK FOR SPECIFIC DETAILS

NOTES:  
 1) HDPE PIPE SHALL HAVE A MINIMUM 1' OF COVER.  
 2) COMPACTIONS CERTIFICATIONS ARE REQUIRED FOR HDPE PIPE BACKFILL. IF APPLICANT IS UNABLE TO FIND A SOURCE FOR CERTIFICATIONS, SEVERAL REFERENCES CAN BE PROVIDED.  
 3) MAXIMUM DRIVEWAY TOP WIDTH IS 30'.

PLACE SILT FENCE THROUGH SWALE FROM TOP OF BANK TO TOP OF BANK AT PROPERTY LINE

PLACE SILT FENCE THROUGH SWALE FROM TOP OF BANK TO TOP OF BANK AT PROPERTY LINE

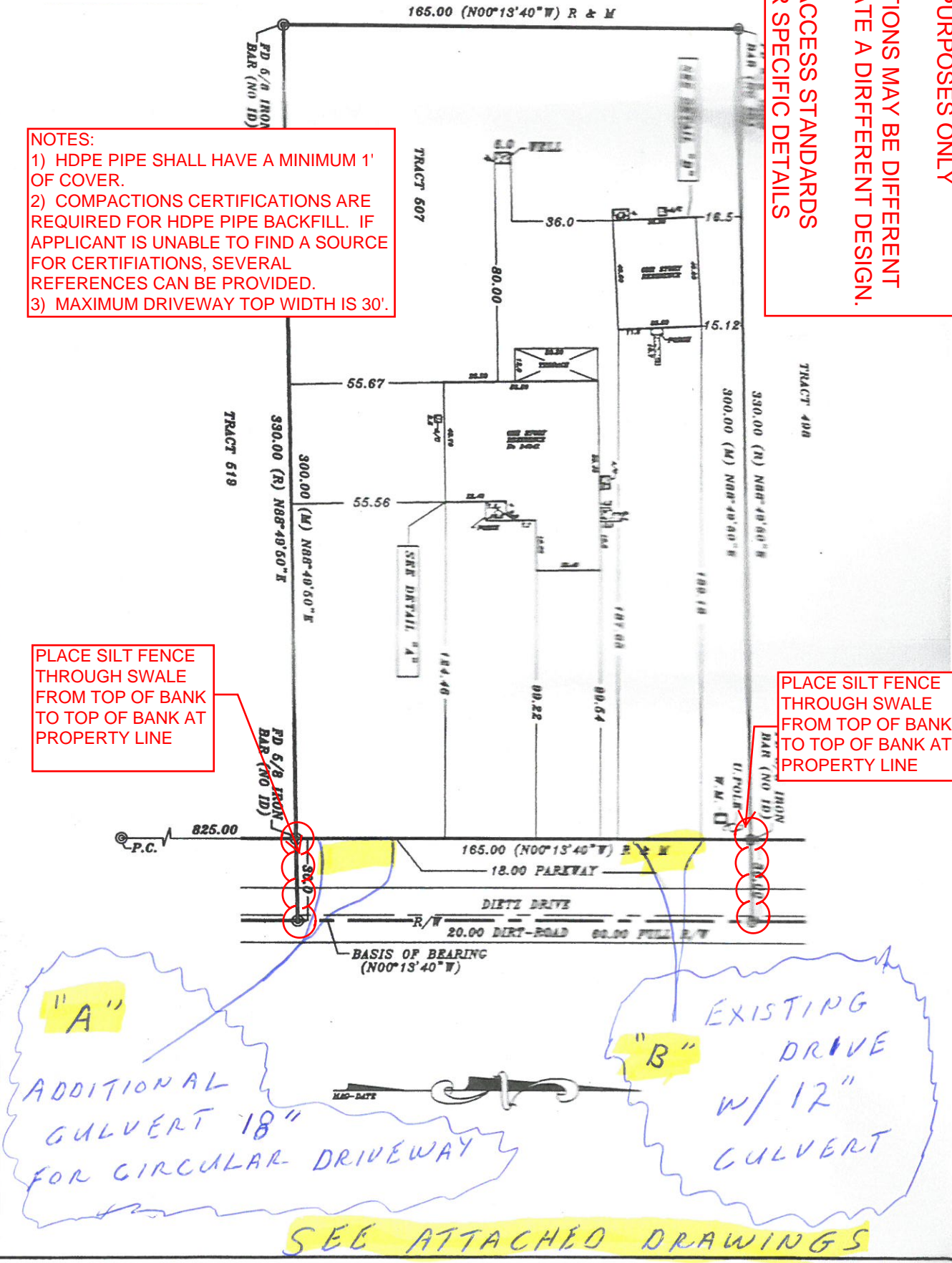

to be made to determine  
 any and all subject to  
 review of the  
 testing the company.  
 attempted to locate  
 and/or adjacent to the  
 at be check before design  
 3/4 meridian,  
 1928, B.M.  
 live use of the entities named herein,  
 HIS  
 JER COUNTY.

REVISIONS	DATE
BOUNDARY SURV.	05-26-06
WORK ORDER 7590	FB/P.G.

"A"

NOT TO SCALE

NORTH

SOUTH LOT LINE

3' MITERED  
3-1 SLOPE  
EACH END

18" IN DIAMETER

30' FINISHED

SILT FENCE TO BE  
INSTALLED AT N & S LOT LINE

BOTTOM  
END OF  
CULVERT  
PIPE  
1' N/O  
LOT LINE

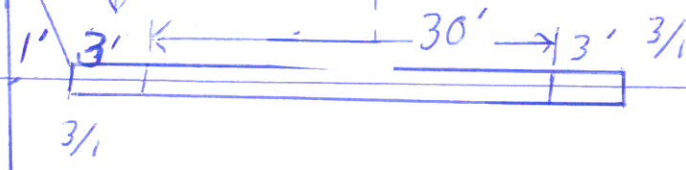

BOTTOM OF DITCH

C/L  
OF  
DITCH

"B"

NORTH  
LOT  
LINE

EXISTING CULVERT IS 20' 6"  
WITH NO MITERED ENDS  
NOW 16' FROM NORTH LOT LINE

EXISTING CULVERT IS 12" IN DIAMETER  
EXTENDING WITH SAME

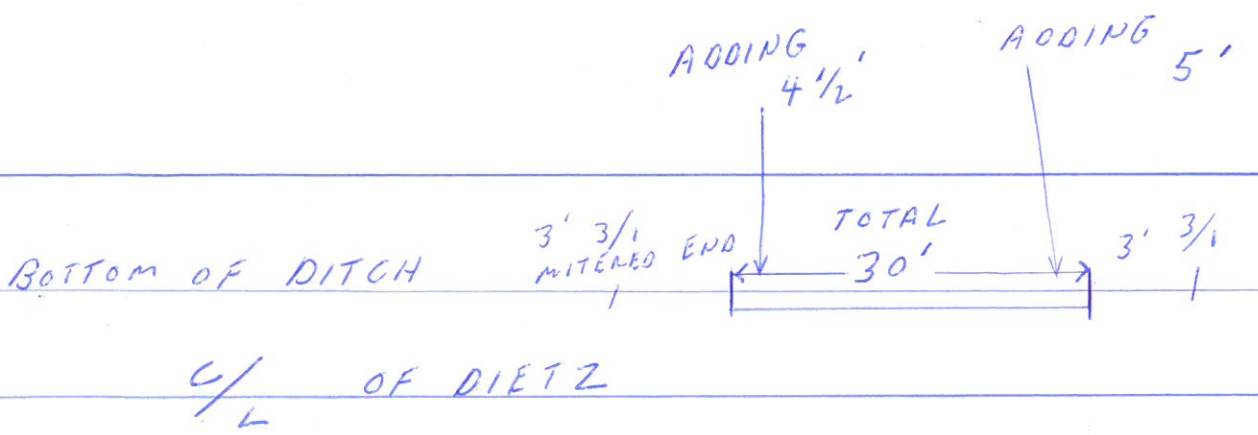

BOTTOM OF DITCH

C/L  
OF DITCH

FOR EXAMPLE PURPOSES ONLY  
ACTUAL CONDITIONS MAY BE DIFFERENT  
AND NECESSITATE A DIFFERENT DESIGN.  
CONSULT THE ACCESS STANDARDS  
HANDBOOK FOR SPECIFIC DETAILS

APPENDIX B  
TEMPORARY EROSION CONTROL DETAILS  
MITERED END SECTION DETAILS



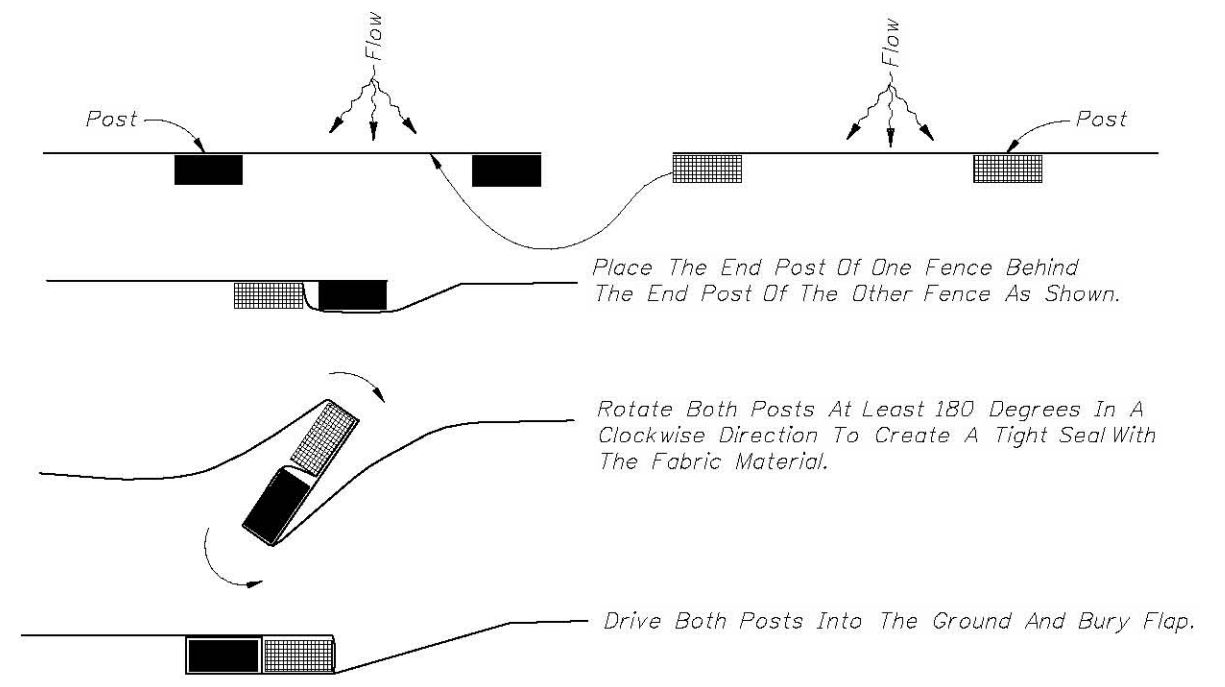
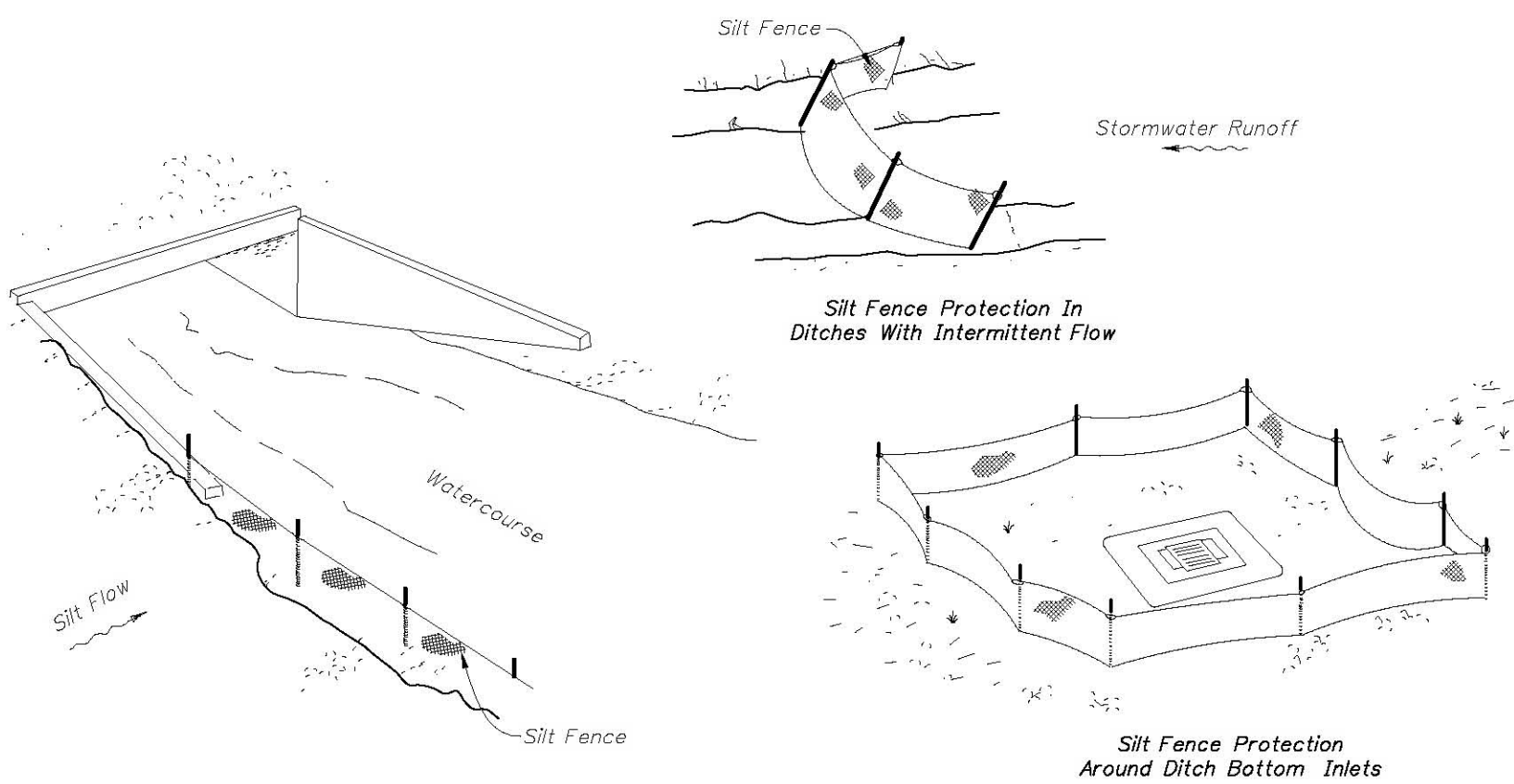
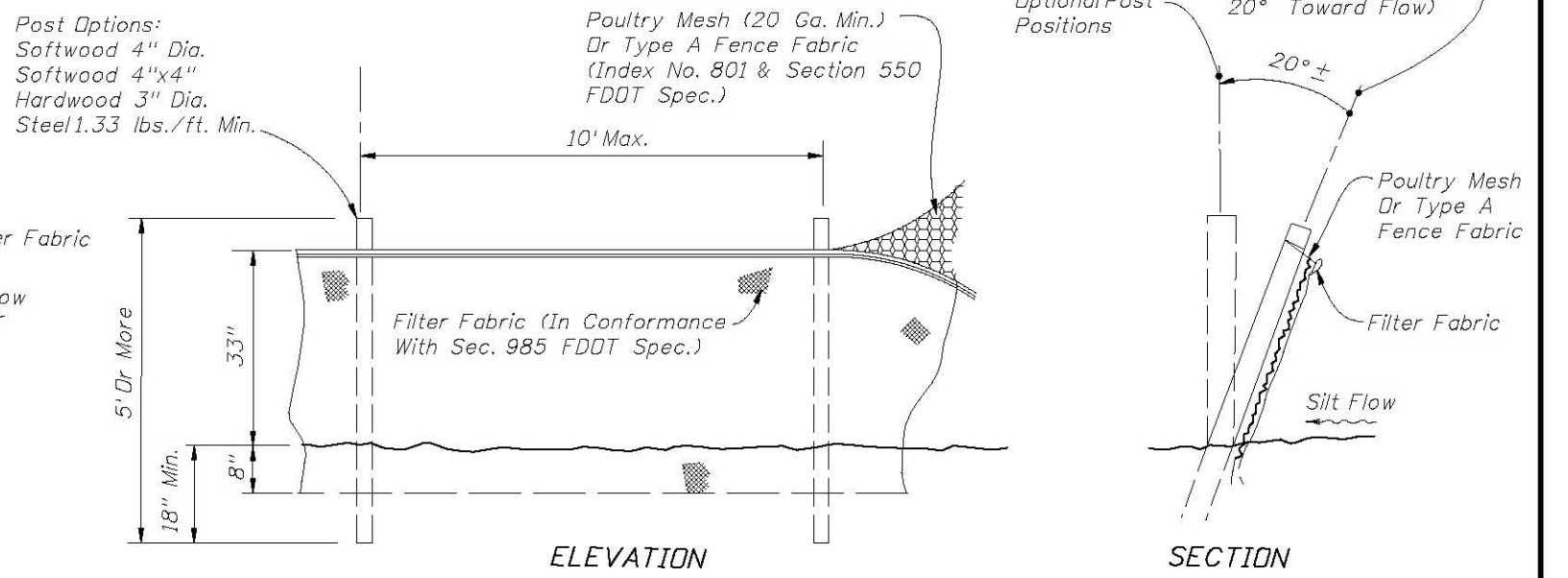
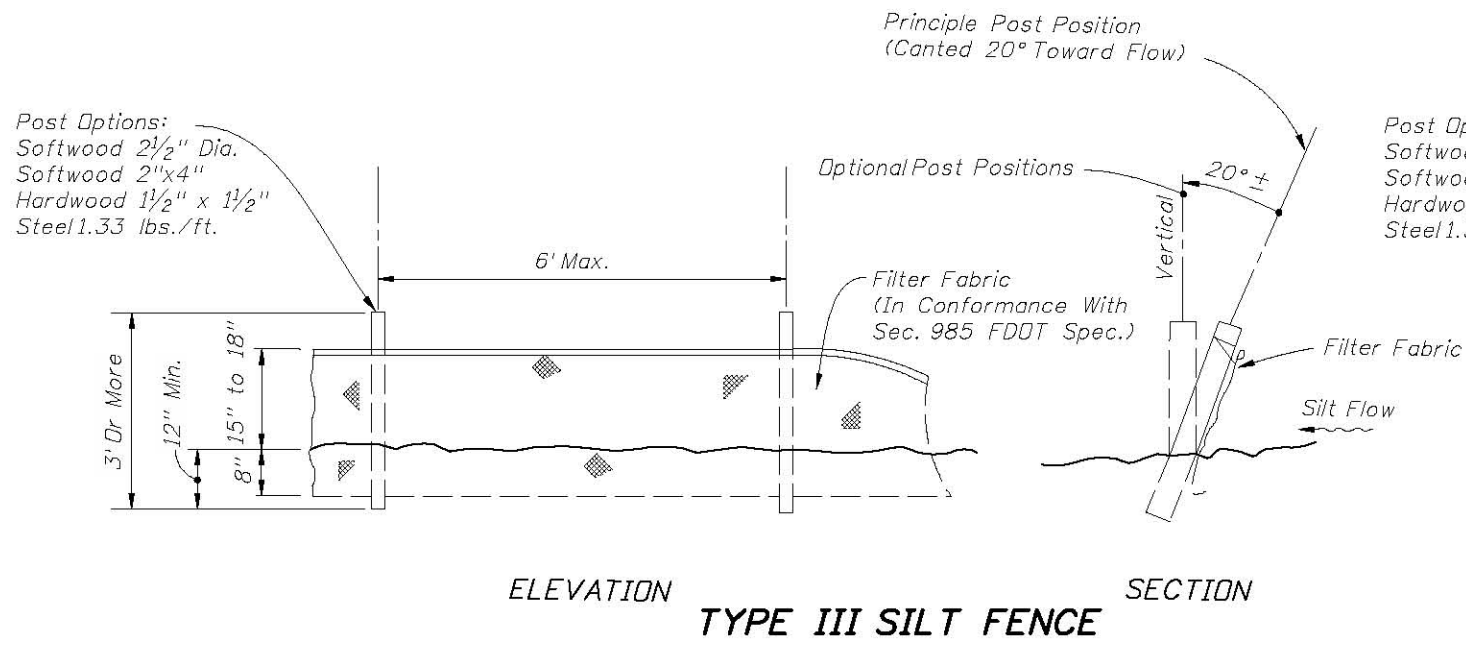

**SILT FENCE APPLICATIONS**

**PLAN VIEW JOINING TWO SILT FENCES**

**NOTES FOR SILT FENCES**

1. Type III Silt Fence to be used at most locations. Where used in ditches, the spacing for Type III Silt fence shall be in accordance with Chart 1, Sheet 1.
2. Type IV Silt Fence to be used where large sediment loads are anticipated. Suggested use is where fill slope is 1:2 or steeper and length of slope exceeds 25 feet. Avoid use where the detained water may back into travel lanes or off the right of way.
3. Do not construct silt fences across permanent flowing watercourses. Silt fences are to be at upland locations and turbidity barriers used at permanent bodies of water.
4. Where used as slope protection, Silt Fence is to be constructed on 0% longitudinal grade to avoid channelizing runoff along the length of the fence.
5. Silt Fence to be paid for under the contract unit price for Staked Silt Fence, (LF).



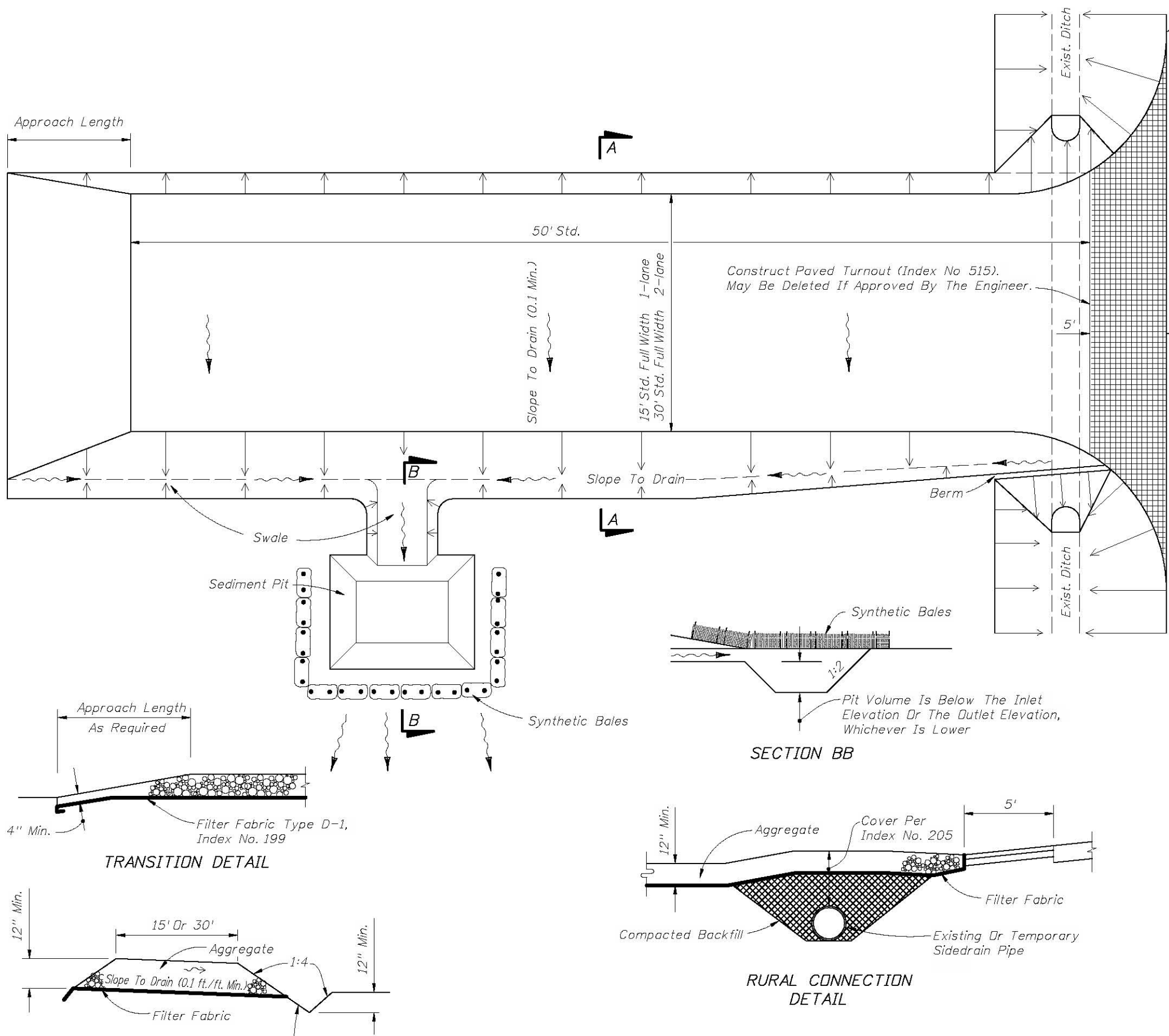

Existing Roadway  
Edge Of Pavement

**GENERAL NOTES**

1. A Soil Tracking Prevention Device (STPD) shall be constructed at locations designated by the engineer for points of egress from unstabilized areas of the project to public roads where off-site tracking of mud could occur. Traffic from unstabilized areas of the construction project shall be directed thru a STPD. Barriers, flagging, or other positive means shall be used as required to limit and direct vehicular egress across the STPD.
2. The Contractor may propose an alternative technique to minimize off-site tracking of sediment. The alternative must be reviewed and approved by the Engineer prior to its use.
3. All materials spilled, dropped, or tracked onto public roads (including the STPD aggregate and construction mud) shall be removed daily, or more frequently if so directed by the Engineer.
4. Aggregates shall be as described in Section 901 excluding 901-2.3. Aggregates shall be FDOT size #1. If this size is not available, the next available smaller size aggregate may be substituted with the approval of the Engineer. Sizes containing excessive small aggregate will track off the project and are unsuitable.
5. The sediment pit should provide a retention volume of 3600 cubic feet/acre of surface area draining to the pit.  
When the STPD is isolated from other drainage areas, the following pit volumes will satisfy this requirement:  
 $15' \times 50' = 100 \text{ ft.}^3$      $30' \times 50' = 200 \text{ ft.}^3$   
As an option to the sediment pit, the width of the swale bottom can be increased to obtain the volume. When the sediment pit or swale volume has been reduced to one half, it shall be cleaned. When a swale is used, synthetic bales or silt fence shall be placed along the entire length.
6. The swale ditch draining the STPD shall have a 0.02% minimum and a 1.0% maximum grade along the STPD and to the sediment pit.
7. Mitered end sections are not required when the sidedrain pipe satisfies the clear zone requirements.
8. The STPD shall be maintained in a condition that will allow it to perform its function. To prevent off-site tracking, the STPD shall be rinsed (daily when in use) to move accumulated mud downward thru the stone. Additional stabilization of the vehicular route leading to the STPD may be required to limit the mud tracked.
9. A STPD shall be paid for under the contract unit price for Soil Tracking Prevention Device, EA. The unit price shall constitute full compensation for construction, maintenance, replacement of materials, removal, and restoration of the area utilized for the STPD; including but not limited to excavation, grading, temporary pipe (including MES when required), filter fabric, aggregate, paved turnout (including asphalt and base construction), ditch stabilization, approach route stabilization, sediment removal and disposal, water, rinsing and cleaning of the STPD and cleaning of public roads, grassing and sod. Synthetic Bale or Bale Type Barrier shall be paid for under the contract unit price for Synthetic Bales, LF. Silt fence shall be paid for under the contract unit price for Staked Silt Fence, LF.
10. The nominal size of a standard STPD is 15' x 50' unless otherwise shown in the plans. If the volume of entering and existing vehicles warrant, a 30' width STPD may be used if approved by the Engineer. When a double width (30') STPD is used, the pay quantity shall be 2 for each location.

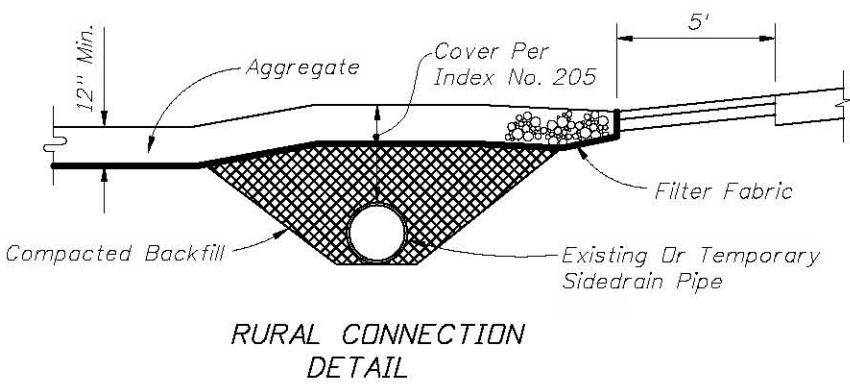
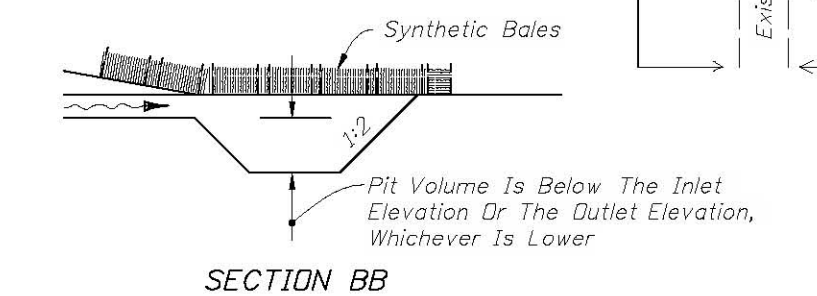
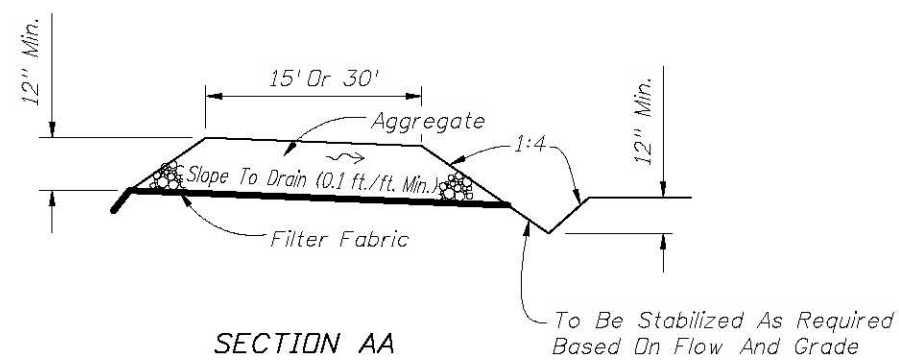
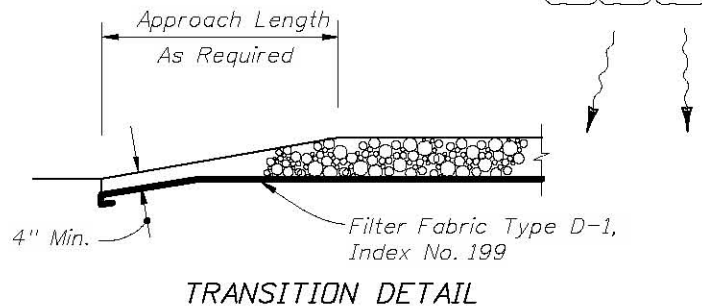

DIMENSIONS AND QUANTITIES

	D	X	A	B	C	E	F	G	H ■	M				N	5 1/2" CONCRETE SLAB (CY) ■				SODDING (SQ. YDS.)			
										Single Pipe	Double Pipe	Triple Pipe	Quad. Pipe		Single Pipe	Double Pipe	Triple Pipe	Quad. Pipe	Single Pipe	Double Pipe	Triple Pipe	Quad. Pipe
1:2 Slope	15"	2'-7"	1.92'	2.18'	4.10'	2.06'	5'	1.22'	2.9'	4.63'	7.21'	9.79'	12.37'	1.19'	0.38	0.58	0.77	0.96	21	24	27	30
	18"	2'-10"	1.97'	2.74'	4.71'	2.56'	6'	1.41'	3.4'	4.92'	7.75'	10.58'	13.42'	1.21'	0.44	0.65	0.87	1.09	22	25	28	31
	24"	3'-5"	2.06'	3.85'	5.91'	3.56'	7'	1.73'	3.4'	5.50'	8.92'	12.33'	15.75'	1.25'	0.54	0.83	1.12	1.42	24	28	32	35
	30"	4'-3"	2.15'	4.95'	7.10'	4.56'	8'	2.00'	3.4'	6.08'	10.33'	14.58'	18.83'	1.29'	0.66	1.09	1.50	1.91	26	31	35	40
	36"	5'-1"	2.25'	6.08'	8.33'	5.56'	9'	2.24'	3.4'	6.67'	11.75'	16.83'	21.92'	1.33'	0.81	1.38	1.95	2.51	28	34	39	45
	42"	6'-0"	2.34'	7.21'	9.55'	6.56'	10'	2.45'	3.4'	7.25'	13.25'	19.25'	25.25'	1.38'	0.97	1.70	2.45	3.19	30	37	43	50
	48"	6'-9"	2.43'	8.33'	10.76'	7.56'	11'	2.65'	3.4'	7.83'	14.58'	21.33'	28.08'	1.42'	1.13	2.04	2.93	3.84	32	39	47	54
	54"	7'-8"	2.52'	9.44'	11.96'	8.56'	12'	2.83'	3.4'	8.42'	16.08'	23.75'	31.42'	1.46'	1.31	2.44	3.58	4.72	34	42	51	59
	60"	8'-6"	2.62'	10.56'	13.18'	9.56'	14'	3.00'	4.4'	9.00'	17.50'	26.00'	34.50'	1.50'	1.51	2.89	4.28	5.68	36	45	55	64
	66"	9'-2"	2.71'	11.68'	14.39'	10.56'	15'	3.18'	4.4'	9.58'	18.75'	27.92'	37.08'	1.54'	1.68	3.25	4.84	6.43	38	48	58	68
72"	10'-0"	2.80'	12.80'	15.60'	11.56'	16'	3.30'	4.4'	10.16'	20.16'	30.16'	40.16'	1.58'	1.89	3.74	5.59	7.45	40	51	62	73	
1:4 Slope	15"	2'-7"	2.27'	4.09'	6.36'	4.03'	8'	1.22'	4.0'	4.63'	7.21'	9.79'	12.37'	1.19'	0.57	0.87	1.15	1.44	23	26	29	32
	18"	2'-10"	2.36'	5.12'	7.48'	5.03'	9'	1.41'	4.0'	4.92'	7.75'	10.58'	13.42'	1.21'	0.66	0.99	1.31	1.65	25	28	31	35
	24"	3'-5"	2.53'	7.18' Δ	9.71'	7.03' Δ	11'	1.73'	4.0'	5.50'	8.92'	12.33'	15.75'	1.25'	0.85	1.30	1.75	2.20	28	32	36	40
	30"	4'-3"	2.70'	9.25'	11.95'	9.03'	13'	2.00'	4.0'	6.08'	10.33'	14.58'	18.83'	1.29'	1.10	1.74	2.39	3.05	31	36	41	46
	36"	5'-1"	2.87'	11.31' ◇	14.18'	11.03' ◇	15'	2.24'	4.0'	6.67'	11.75'	16.83'	21.92'	1.33'	1.32	2.21	3.08	3.96	34	40	46	52
	42"	6'-0"	3.05'	13.37'	16.42'	13.03'	17'	2.45'	4.0'	7.25'	13.25'	19.25'	25.25'	1.38'	1.58	2.76	3.91	5.09	38	44	51	58
	48"	6'-9"	3.22'	15.43'	18.65'	15.03'	19'	2.65'	4.0'	7.83'	14.58'	21.33'	28.08'	1.42'	1.85	3.30	4.73	6.17	41	48	56	63
	54"	7'-8"	3.39'	17.49'	20.88'	17.03'	21'	2.83'	4.0'	8.42'	16.08'	23.75'	31.42'	1.46'	2.14	3.95	5.77	7.58	44	52	61	69
	60"	8'-6"	3.56'	19.55'	23.11'	19.03'	23'	3.00'	4.0'	9.00'	17.50'	26.00'	34.50'	1.50'	2.45	4.66	6.87	9.07	47	56	66	75
	66"	9'-2"	3.73'	21.62'	25.35'	21.03'	25'	3.18'	4.0'	9.58'	18.75'	27.92'	37.08'	1.54'	2.88	5.54	8.18	10.84	49	59	69	80
72"	10'-0"	3.91'	23.68'	27.59'	23.03'	27'	3.30'	4.0'	10.16'	20.16'	30.16'	40.16'	1.58'	3.54	6.61	9.87	13.13	52	63	74	85	

■ See General Note No. 3.  
See Sheet 5 Of 6 For 3" Slab Quantities

■ Values shown for estimating pipe quantities and are for information only.

B E  
Δ 6.42' Δ 6.25' Dimensions permitted to allow use of 8' standard pipe lengths.

◇ 10.40' ◇ 10.10' Dimensions permitted to allow use of 12' standard pipe lengths.

Δ◇ Concrete slab shall be deepened to form bridge across crown of pipe. See section below.

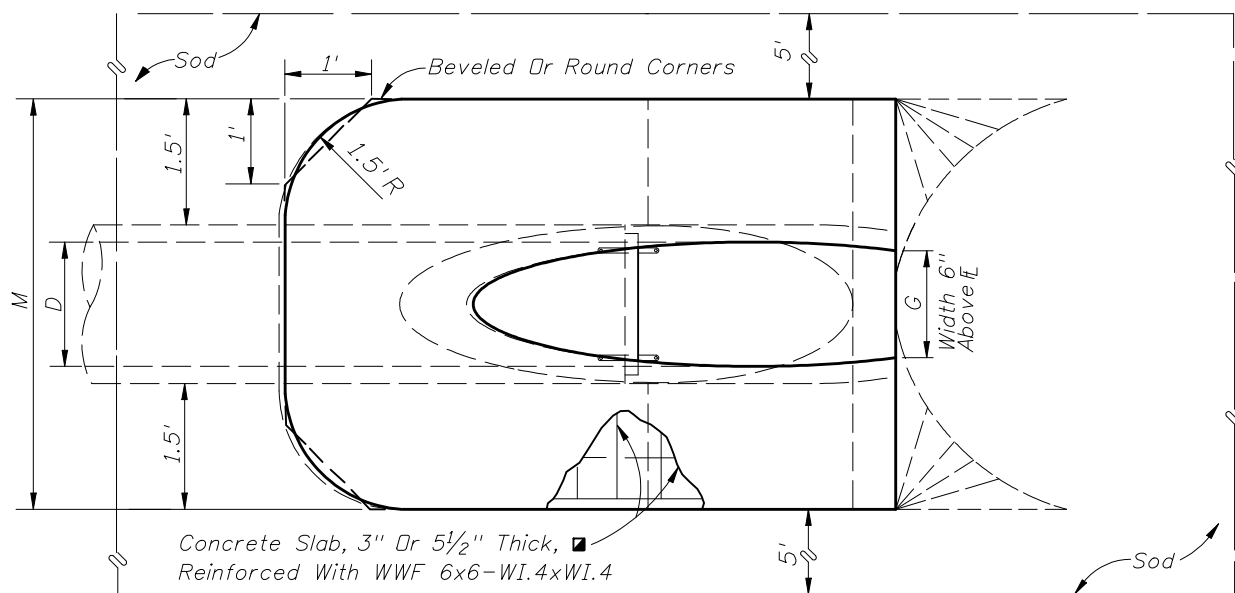

TOP-VIEW SINGLE PIPE

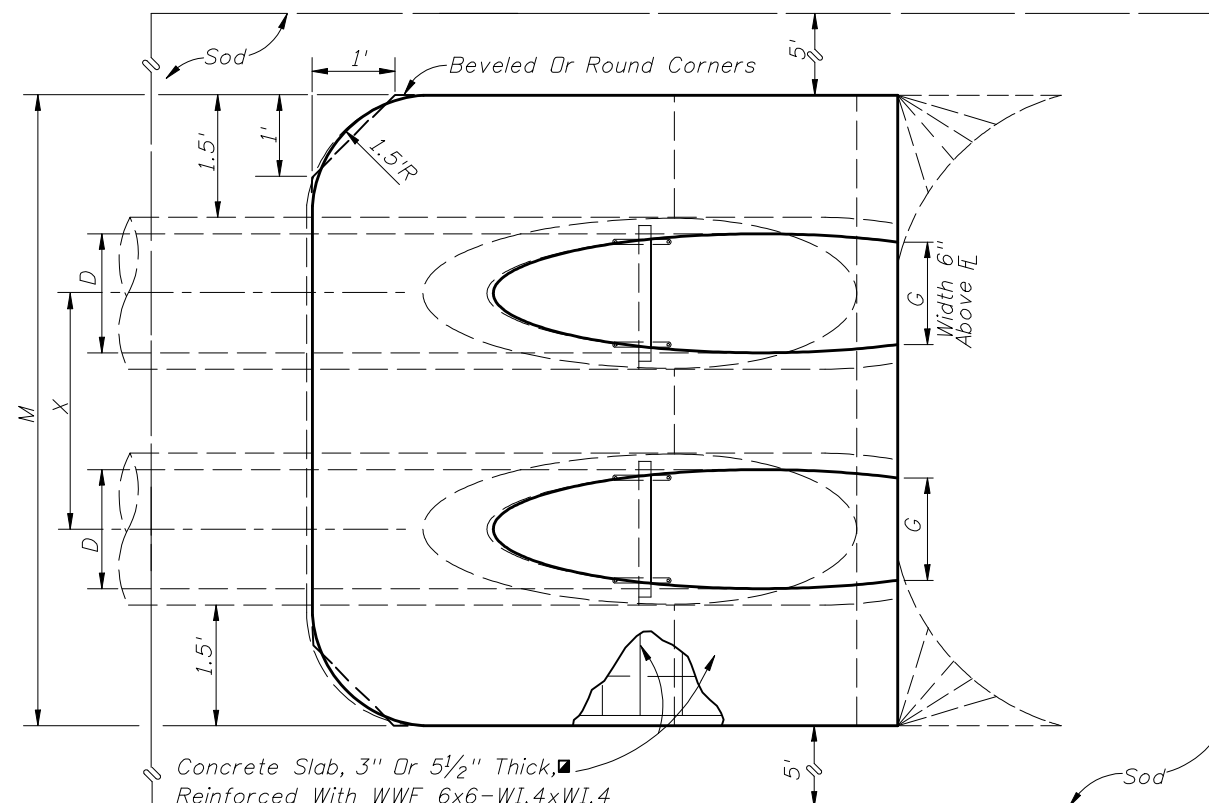

TOP-VIEW MULTIPLE PIPE

NOTE: See sheet 6 for details and notes.

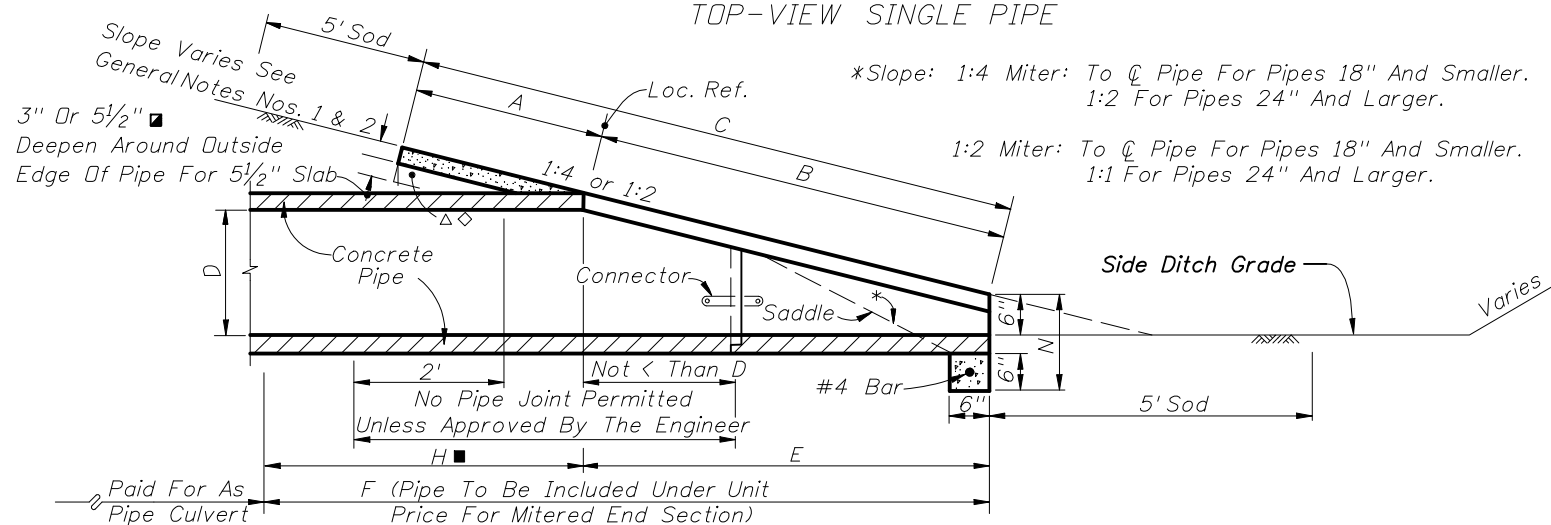

SECTION

SINGLE AND MULTIPLE ROUND CONCRETE PIPE



2010 FDOT Design Standards

CROSS DRAIN MITERED END SECTION

Last Revision 02  
Sheet No. 1 of 6  
Index No. 272

**DIMENSIONS & QUANTITIES**

	Rise R	Span S	X	A	B	C	E	F	G	H	M				N	5 1/2" CONC. SLAB (CY) ▣				SODDING (SQ. YDS.)			
											Single Pipe	Double Pipe	Triple Pipe	Quad. Pipe		Single Pipe	Double Pipe	Triple Pipe	Quad. Pipe	Single Pipe	Double Pipe	Triple Pipe	Quad. Pipe
1:2 Slope	12"	18"	2'-10"	1.97'	1.62'	3.59'	1.56'	4'	1.50'	2.4'	4.92'	7.75'	10.58'	13.42'	1.21'	0.30	0.49	0.67	0.85	21	24	27	30
	14"	23"	3'-4"	2.01'	1.99'	4.00'	1.89'	5'	1.90'	3.1'	5.38'	8.71'	12.04'	15.38'	1.23'	0.37	0.59	0.81	1.02	22	26	29	33
	19"	30"	4'-0"	2.11'	2.92'	5.03'	2.73'	6'	2.37'	3.3'	6.04'	10.04'	14.04'	18.04'	1.27'	0.50	0.80	1.09	1.39	24	28	33	37
	24"	38"	5'-0"	2.20'	3.85'	6.05'	3.56'	7'	2.85'	3.4'	6.79'	11.79'	16.79'	21.79'	1.31'	0.62	1.03	1.45	1.86	26	31	37	42
	29"	45"	5'-11"	2.34'	4.79'	7.13'	4.39'	8'	3.19'	3.6'	7.50'	13.42'	19.33'	25.25'	1.38'	0.75	1.30	1.84	2.39	28	34	41	47
	34"	53"	7'-0"	2.43'	5.72'	8.15'	5.23'	9'	3.57'	3.8'	8.25'	15.25'	22.25'	29.25'	1.42'	0.90	1.61	2.32	3.03	30	37	45	53
	38"	60"	7'-10"	2.52'	6.46'	8.98'	5.89'	9'	3.95'	3.1'	8.92'	16.75'	24.58'	32.42'	1.46'	1.03	1.89	2.74	3.60	31	40	49	57
	43"	68"	8'-11"	2.62'	7.39'	10.01'	6.73'	10'	4.28'	3.3'	9.67'	18.58'	27.50'	36.42'	1.50'	1.19	2.26	3.33	4.40	33	43	53	63
	48"	76"	9'-11"	2.71'	8.33'	11.04'	7.56'	11'	4.59'	3.4'	10.42'	20.33'	30.25'	40.17'	1.54'	1.38	2.65	3.93	5.21	35	46	57	68
	53"	83"	10'-8"	2.80'	9.26'	12.06'	8.39'	12'	4.77'	3.6'	11.08'	21.75'	32.42'	43.08'	1.58'	1.55	3.03	4.50	5.96	37	49	61	73
58"	91"	11'-8"	2.90'	10.19'	13.09'	9.23'	13'	5.01'	3.8'	11.83'	23.50'	35.17'	46.83'	1.63'	1.75	3.47	5.20	6.93	39	52	65	78	
1:4 Slope	12"	18"	2'-10"	2.36'	3.06'	5.42'	3.03'	5'	1.50'	2.0'	4.92'	7.75'	10.58'	13.42'	1.21'	0.45	0.68	0.92	1.14	23	26	29	32
	14"	23"	3'-4"	2.44'	3.75'	6.19'	3.70'	6'	1.90'	2.3'	5.38'	8.71'	12.04'	15.38'	1.23'	0.53	0.83	1.13	1.42	24	28	32	35
	19"	30"	4'-0"	2.62'	5.47'	8.09'	5.36'	8'	2.37'	2.6'	6.04'	10.04'	14.04'	18.04'	1.27'	0.74	1.15	1.57	1.98	27	32	36	40
	24"	38"	5'-0"	2.79'	7.18'	9.97'	7.03'	10'	2.85'	3.0'	6.79'	11.79'	16.79'	21.79'	1.31'	0.97	1.57	2.19	2.81	30	36	41	47
	29"	45"	5'-11"	3.05'	8.90'	11.95'	8.70'	12'	3.19'	3.3'	7.50'	13.42'	19.33'	25.25'	1.38'	1.22	2.07	2.92	3.77	33	40	46	53
	34"	53"	7'-0"	3.22'	10.62'	13.84'	10.36'	13'	3.57'	2.6'	8.25'	15.25'	22.25'	29.25'	1.42'	1.48	2.62	3.77	4.92	36	44	52	59
	38"	60"	7'-10"	3.39'	11.99'	15.38'	11.70'	15'	3.95'	3.3'	8.92'	16.75'	24.58'	32.42'	1.46'	1.72	3.12	4.53	5.92	38	47	56	65
	43"	68"	8'-11"	3.56'	13.71'	17.27'	13.36'	17'	4.28'	3.6'	9.67'	18.58'	27.50'	36.42'	1.50'	2.02	3.78	5.56	7.32	41	51	61	71
	48"	76"	9'-11"	3.73'	15.43'	19.16'	15.03'	19'	4.59'	4.0'	10.42'	20.33'	30.25'	40.17'	1.54'	2.34	4.49	6.64	8.79	44	55	66	77
	53"	83"	10'-8"	3.91'	17.15'	21.06'	16.70'	20'	4.77'	3.3'	11.08'	21.75'	32.42'	43.08'	1.58'	2.66	5.17	7.66	10.16	47	59	71	83
58"	91"	11'-8"	4.08'	18.87'	22.95'	18.36'	22'	5.01'	3.6'	11.83'	23.50'	35.17'	46.83'	1.63'	3.02	5.98	8.95	11.90	50	63	76	89	

▣ See General Note No. 3.  
See Sheet 5 Of 6 For 3" Slab Quantities

■ Values shown for estimating pipe quantities and are for information only.

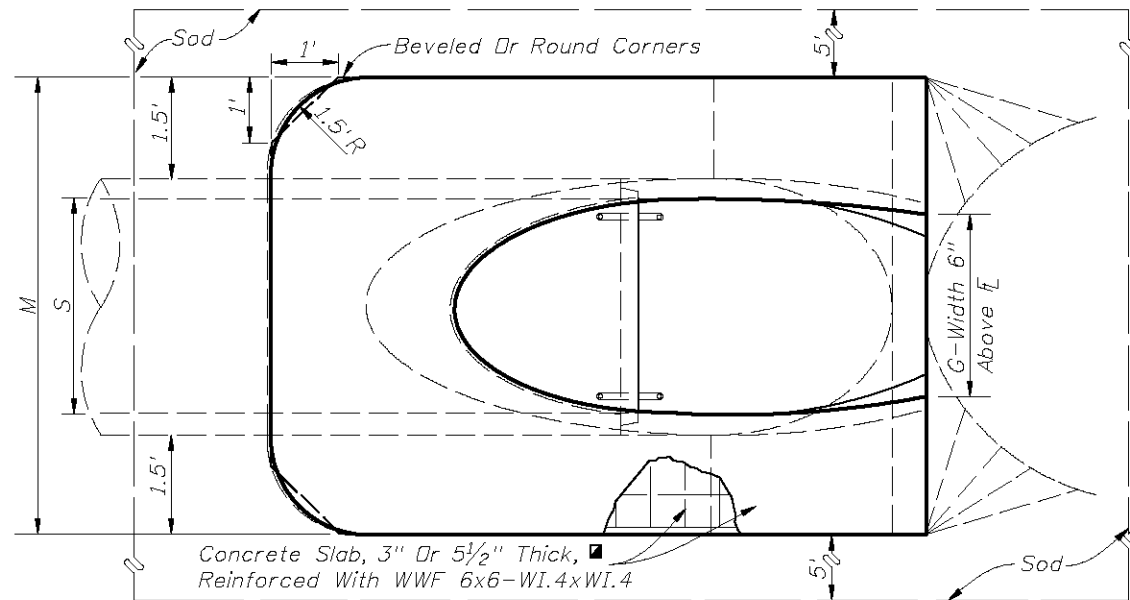

TOP VIEW-SINGLE PIPE

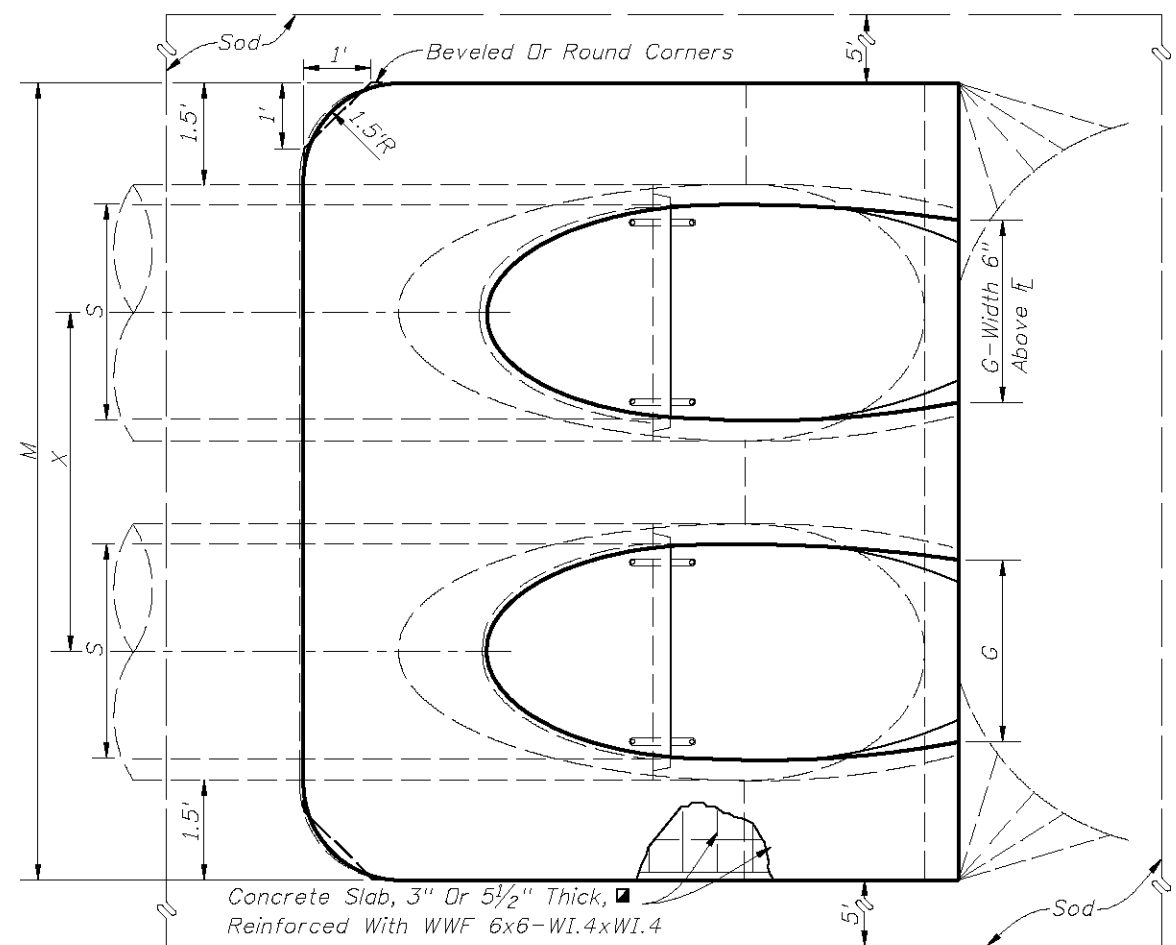

NOTE: See Sheet 6 For Details And Notes.

TOP VIEW - MULTIPLE PIPE

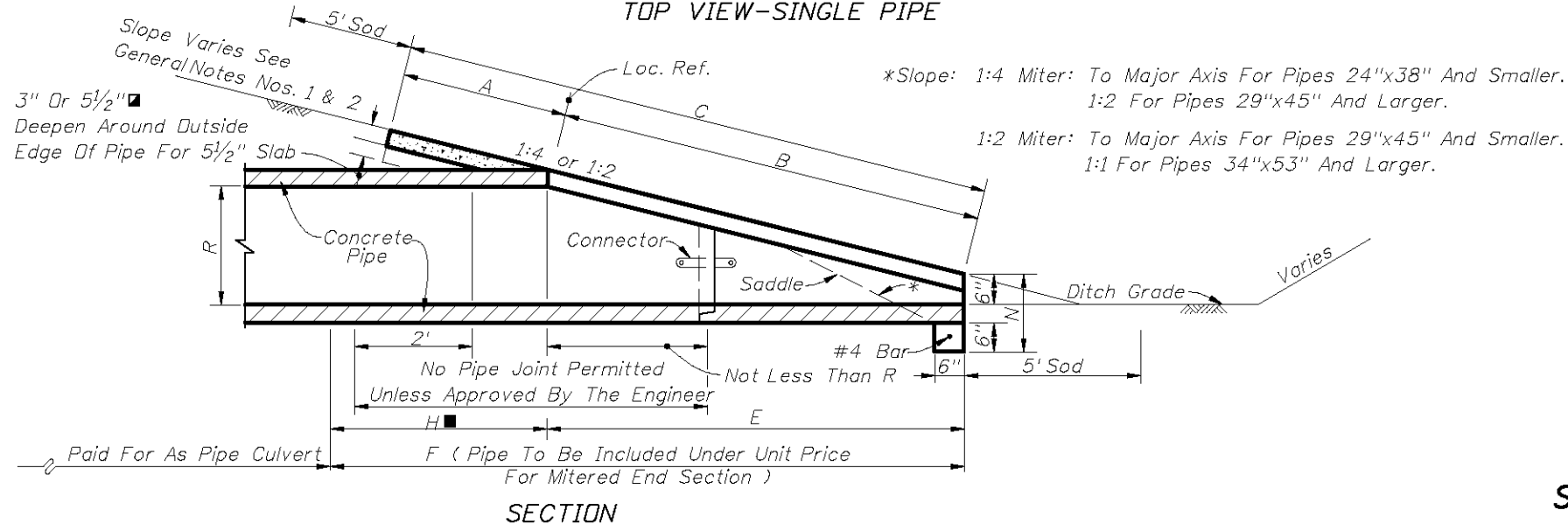

SECTION

**SINGLE AND MULTIPLE ELLIPTICAL CONCRETE PIPE**



2010 FDOT Design Standards

**CROSS DRAIN MITERED END SECTION**

Last Revision 02 Sheet No. 4 of 6

Index No. 272

APPENDIX C  
ROADWAY TYPICAL SECTIONS

PROJECT:  
**SAN CARLOS ESTATES WATER CONTROL DISTRICT**

ADDRESS:  
 P.O. BOX 367807  
 BONITA SPRINGS, FL 34136



CONSULTANT:

**MORRIS DEPEW**  
 ENGINEERS • PLANNERS • SURVEYORS  
 LANDSCAPE ARCHITECTS  
 FL CA #10, 6532 / FL CERT #10, L96891 / LC20000330

**Fort Myers**  
 2891 Center Pointe Drive  
 Unit 100  
 Fort Myers, Florida 33916  
 (239) 337-3993  
 Fax: (239) 337-3994  
 Toll free: 866-337-7341

**Tallahassee**  
 327 Office Plaza  
 Suite 113  
 Tallahassee, Florida 32301  
 (850) 224-6688

**Gainesville**  
 414 SW 140th Terrace  
 Suite 100  
 Newberry, FL 32069  
 (352) 378-3450

**Destin**  
 755 Grand Boulevard  
 Suite B105-152  
 Miramar Beach, FL 32550  
 Toll free: 866-337-7341

SEAL:

---

REVISIONS	DATE

PROJECT MANAGER: BM  
 DRAWING BY: MDH  
 JURISDICTION: SCEWCD  
 DATE: 01/13/2014

TITLE: **BONITA BILL STREET TYPICAL SECTION**

SHEET NUMBER:

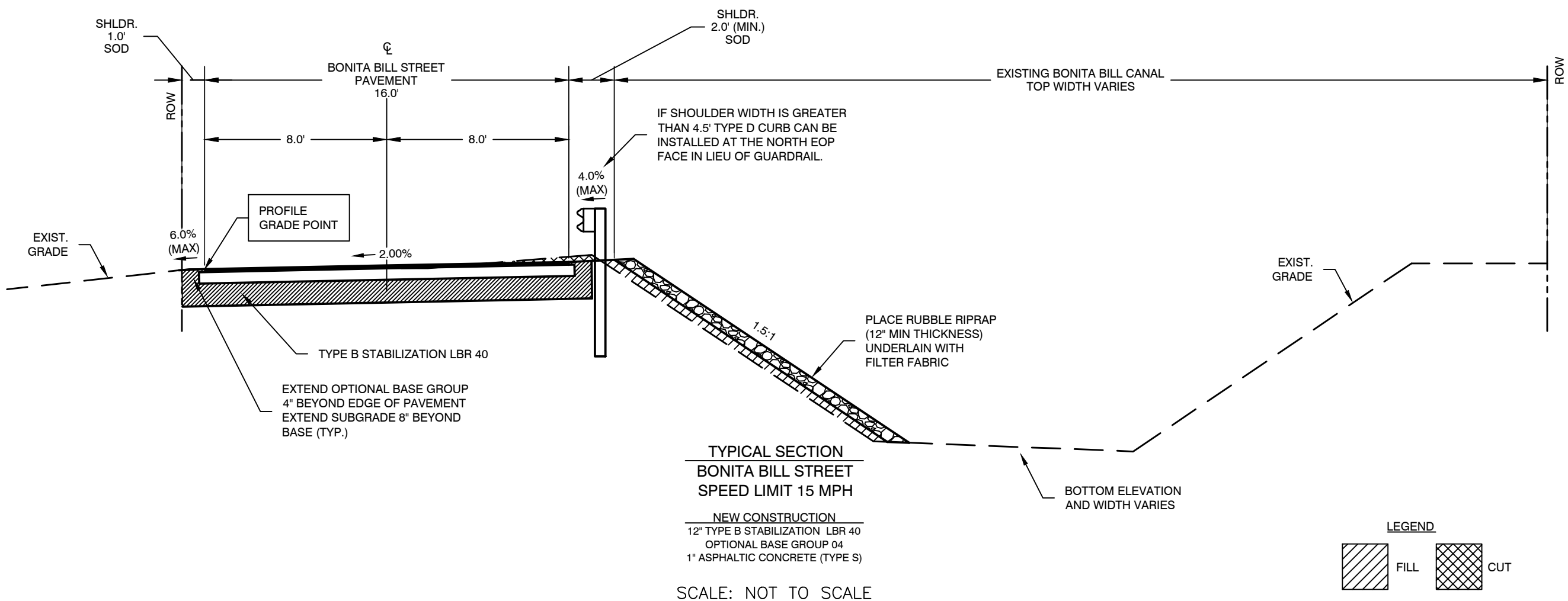
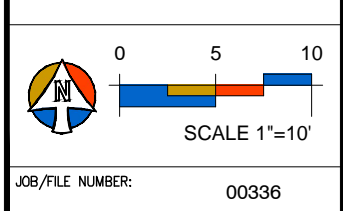

NOTES:  
 1) ROADWAY PROFILE TO BE PROVIDED BY SAN CARLOS ESTATES WATER CONTROL DISTRICT.

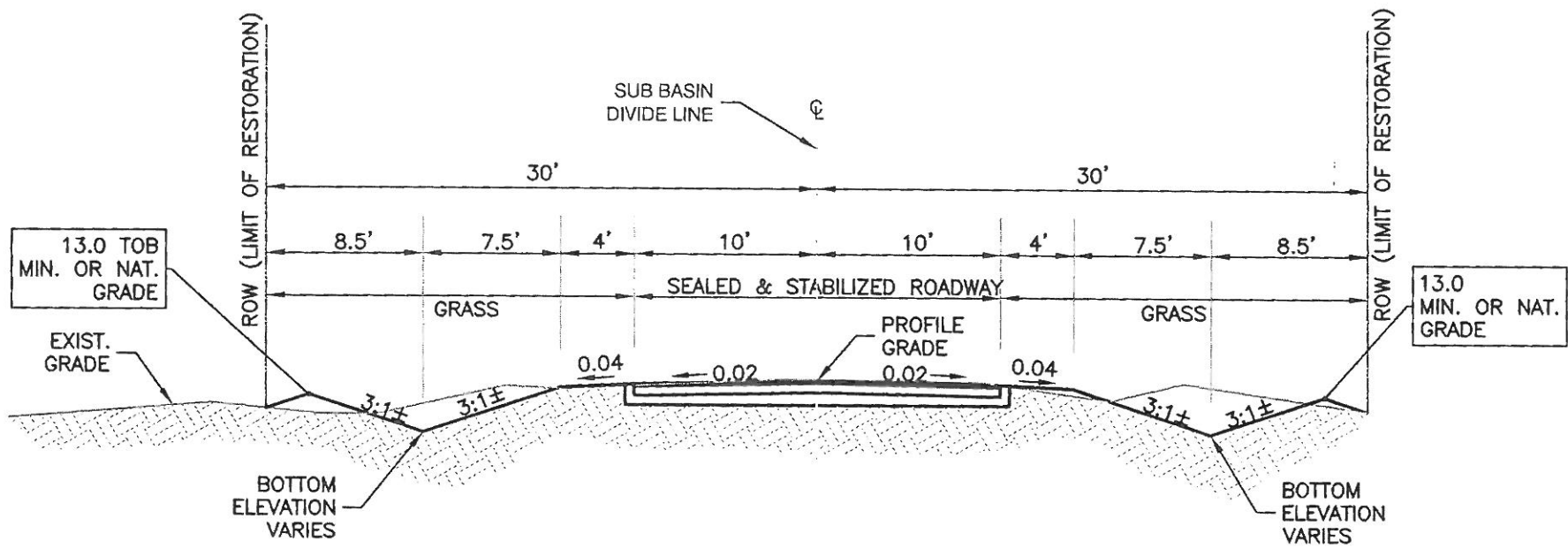

PAVEMENT  
 1" ASPHALTIC CONCRETE (TYPE S)  
 6" LIMEROCK BASE, (LBR 100, 98% DENSITY MOD. PROCTOR)  
 6" STABILIZED SUBGRADE, TYPE B, (LBR 40, 95% DENSITY MOD. PROCTOR)

6

RESTORED TYPICAL ROADWAY SECTION

N.T.S.

APPENDIX D  
SPECIFICATIONS



## EARTHWORK AND RELATED OPERATIONS

### SECTION 120 EXCAVATION AND EMBANKMENT

#### **120-1 Description.**

**120-1.1 General:** Excavate and construct embankments as required for the roadway, ditches, channel changes and borrow material. Use suitable excavated material or authorized borrow to prepare subgrades and foundations. Construct embankments in accordance with Design Standards, Index 505. Compact and dress excavated areas and embankments.

For excavation and backfilling of structures, comply with the requirements of Section 125. Excavate material for clearing and grubbing in accordance with the requirements of Section 110. Material displaced by the storm sewer or drainage structure system is not included in the earthwork quantities shown in the Plans.

**120-1.2 Unidentified Areas of Contamination:** When encountering or exposing any abnormal condition indicating the presence of contaminated materials, cease operations immediately in the vicinity and notify the Engineer. The presence of tanks or barrels; discolored earth, metal, wood, ground water, etc.; visible fumes; abnormal odors; excessively hot earth; smoke; or other conditions that appear abnormal may indicate the presence of contaminated materials and must be treated with extreme caution.

Make every effort to minimize the spread of contamination into uncontaminated areas. Immediately provide for the health and safety of all workers at the job site and make provisions necessary for the health and safety of the public that may be exposed to any potentially hazardous conditions. Ensure provisions adhere to all applicable laws, rules or regulations covering potentially hazardous conditions and will be in a manner commensurate with the gravity of the conditions.

The Engineer will notify the District Contamination Impact Coordinator (DCIC) who will coordinate selecting and tasking the Department's Contamination Assessment/Remediation Contractor (CAR). Provide access to the potentially contaminated area. Preliminary investigation by the CAR Contractor will determine the course of action necessary for site security and the steps necessary under applicable laws, rules, and regulations for additional assessment and/or remediation work to resolve the contamination issue.

The CAR Contractor will delineate the contamination areas, any staging or holding area required; and, in cooperation with the Prime Contractor and Engineer, develop a work plan that will provide the CAR Contractor's operations schedule with projected completion dates for the final resolution of the contamination issue.

The CAR Contractor will maintain jurisdiction over activities inside any outlined contaminated areas and any associated staging holding areas. The CAR Contractor will be responsible for the health and safety of workers within the delineated areas. Provide continuous access to these areas for the CAR Contractor and representatives of regulatory or enforcement agencies having jurisdiction.

Both Contractors will use the schedule as a basis for planning the completion of both work efforts. The Engineer may grant the Contract Time extensions according to the provisions of 8-7.3.2.

Cooperate with the CAR Contractor to expedite integration of the CAR Contractor's operations into the construction project. The Prime Contractor is not expected to

engage in routine construction activities, such as excavating, grading, or any type of soil manipulation, or any construction processes required if handling of contaminated soil, surface water or ground water is involved. All routine construction activities requiring the handling of contaminated soil, surface water or groundwater will be by the CAR Contractor. Adjustments to quantities or to Contract unit prices will be made according to work additions or reductions on the part of the Prime Contractor in accordance with 4-3.

The Engineer will direct the Prime Contractor when operations may resume in the affected area.

## **120-2 Classifications of Excavation.**

**120-2.1 General:** The Department may classify excavation specified under this Section for payment as any of the following: (1) regular excavation, (2) subsoil excavation, (3) lateral ditch excavation, and (4) channel excavation.

If the proposal does not show subsoil excavation or lateral ditch excavation as separate items of payment, include such excavation under the item of regular excavation.

If the proposal shows lateral ditch excavation as a separate item of payment, but does not show channel excavation as a separate item of payment, include such excavation under the item of lateral ditch excavation. Otherwise, include channel excavation under the item of regular excavation.

**120-2.2 Regular Excavation:** Regular excavation includes roadway excavation and borrow excavation, as defined below for each.

**120-2.2.1 Roadway Excavation:** Roadway excavation consists of the excavation and the utilization or disposal of all materials necessary for the construction of the roadway, ditches, channel changes, etc., except as may be specifically shown to be paid for separately and that portion of the lateral ditches within the limits of the roadway right-of-way as shown in the Plans.

**120-2.2.2 Borrow Excavation:** Borrow excavation consists of the excavation and utilization of material from authorized borrow pits, including only material that is suitable for the construction of roadway embankments or of other embankments covered by the Contract.

A Cost Savings Initiative Proposal (CSIP) submittal based on using borrow material from within the project limits will not be considered.

**120-2.3 Subsoil Excavation:** Subsoil excavation consists of the excavation and disposal of muck, clay, rock, or any other material that is unsuitable in its original position and that is excavated below the finished grading template. For stabilized bases and sand bituminous road mixes, consider the finished grading template as the top of the finished base, shoulders and slopes. For all other bases and rigid pavement, consider the finished grading template as the finished shoulder and slope lines and bottom of completed base or rigid pavement. For pond and ditches that identify the placement of a blanket material, consider the finished grading template as the bottom of the blanket material. Subsoil excavation also consists of the excavation of all suitable material within the above limits as necessary to excavate the unsuitable material. Consider the limits of subsoil excavation indicated in the Plans as being particularly variable, in accordance with the field conditions actually encountered.

The quantity of material required to replace the excavated material and to raise the elevation of the roadway to the bottom of the template will be paid for under embankment or borrow excavation (Truck Measure).

**120-2.4 Lateral Ditch Excavation:** Lateral ditch excavation consists of all excavation of inlet and outlet ditches to structures and roadway, changes in channels of streams, and ditches

parallel to the roadway right-of-way. Dress lateral ditches to the grade and cross-section shown in the Plans.

**120-2.5 Channel Excavation:** Channel excavation consists of the excavation and satisfactory disposal of all materials from the limits of the channel as shown in the Plans.

### **120-3 Preliminary Soils Investigations.**

When the Plans contain the results of a soil survey, do not assume such data is a guarantee of the depth, extent, or character of material present.

### **120-4 Removal of Unsuitable Materials and Existing Roads.**

**120-4.1 Subsoil Excavation:** Where muck, rock, clay, or other material within the limits of the roadway is unsuitable in its original position, excavate such material to the cross-sections shown in the Plans or indicated by the Engineer, and backfill with suitable material. Shape backfill material to the required cross-sections. Where the removal of plastic soils below the finished earthwork grade is required, meet a construction tolerance, from the lines shown in the plans as the removal limits, of plus or minus 0.2 feet in depth and plus or minus 6 inches (each side) in width.

**120-4.2 Construction over Existing Old Road:** Where a new roadway is to be constructed over an old one, plow or scarify the old road, and break it up full width, regardless of height of fill. If the Plans provide that paving materials may be incorporated into the fill, distribute such material in a manner so as not to create voids. Recompact the old road meeting the requirements of 120-10.2.

**120-4.3 Obliterating Old Road:** Where the Plans call for obliteration of portions of an old road outside of the proposed new roadway, obliterate such sections of the old road by grading to fill ditches and to restore approximately the original contour of the ground or a contour which produces a pleasing appearance.

### **120-5 Disposal of Surplus and Unsuitable Material.**

**120-5.1 Ownership of Excavated Materials:** Dispose of surplus and excavated materials as shown in the Plans or, if the Plans do not indicate the method of disposal, take ownership of the materials and dispose of them outside the right-of-way.

**120-5.2 Disposal of Muck on Side Slopes:** As an exception to the provisions of 120-5. 1, when approved by the Engineer, in rural undeveloped areas, the Contractor may place muck (A-8 material) on the slopes, or store it alongside the roadway, provided there is a clear distance of at least 6 feet between the roadway grading limits and the muck, and the Contractor dresses the muck to present a neat appearance. In addition, the Contractor may also dispose of this material by placing it on the slopes in developed areas where, in the opinion of the Engineer, this will result in an aesthetically pleasing appearance and will have no detrimental effect on the adjacent developments. Where the Engineer permits the disposal of muck or other unsuitable material inside the right-of-way limits, do not place such material in a manner which will impede the inflow or outfall of any channel or side ditches. The Engineer will determine the limits adjacent to channels within which such materials may be disposed.

**120-5.3 Disposal of Paving Materials:** Unless otherwise noted, take ownership of paving materials, such as paving brick, asphalt block, concrete slab, sidewalk, curb and gutter, etc., excavated in the removal of existing pavements, and dispose of them outside the right-of-way. If the materials are to remain the property of the Department, place them in neat piles as directed. Existing limerock base that is removed may be incorporated in the stabilized portion of

the subgrade. If the construction sequence will allow, incorporate all existing limerock base into the project as allowed by the Contract Documents.

**120-5.4 Disposal Areas:** Where the Contract Documents require disposal of excavated materials outside the right-of-way, and the disposal area is not indicated in the Contract Documents, furnish the disposal area without additional compensation.

Provide areas for disposal of removed paving materials out of sight of the project and at least 300 feet from the nearest roadway right-of-way line of any State maintained road. If the materials are buried, disregard the 300 foot limitation.

## **120-6 Borrow.**

**120-6.1 Materials for Borrow:** Do not open borrow pits until the Engineer has approved their location.

Do not provide borrow materials that are polluted as defined in Chapter 376 of the Florida Statutes (oil of any kind and in any form, gasoline, pesticides, ammonia, chlorine, and derivatives thereof, excluding liquefied petroleum gas) in concentrations above any local, State, or Federal standards.

Prior to placing any borrow material that is the product of soil incineration, provide the Engineer with a copy of the Certificate of Materials Recycling and Post Burn Analysis showing that the material is below all allowable pollutant concentrations.

### **120-6.2 Furnishing of Borrow Areas:**

To obtain the Engineer's approval to use an off-site construction activity area that involves excavation such as a borrow pit or local aggregate pit, request in writing, a review for - cultural resources involvement. Send the request to the Division of Historical Resources (DHR), Department of State, State Historic Preservation Officer, Tallahassee, FL. As a minimum, include in the request the Project Identification Number, the County, a description of the property with Township, Range, Section, etc., the dimensions of the area to be affected, and a location map. Do not start any work at the off-site construction activity area prior to receiving clearance from the DHR that no additional research is warranted.

For certain locations, the DHR will require a Cultural Resources Assessment (CRA) Survey before approval can be granted. When this is required, secure professional archaeological services to complete an historical and archaeological survey report. Submit the report to the DHR with a copy to the Department. The Engineer will determine final approval or rejection of off-site construction activity areas based on input from the DHR.

Before receiving approval or before use of borrow areas, obtain written clearance from the Engineer concerning compliance with the Federal Endangered Species Act and other Wildlife Regulations as specified in 7-1.4 and Section 4(f) of the USDOT Act as specified in 7-1.8.

The Department will adjust Contract Time in accordance with 8-7 for any suspension of operations required to comply with this Article. The Department will not accept any monetary claims due to delays or loss of off-site construction activity areas.

Except where the Plans specifically call for the use of a particular borrow or dredging area, the Contractor may substitute borrow or dredging areas of his own choosing provided: (1) the Engineer determines the materials from such areas meet the Department's standards and other requirements for stability for use in the particular sections of the work in which it is to be placed, and (2) the Contractor absorbs any increase in hauling or other costs. Stake the corners of the proposed borrow area and provide the necessary equipment along with an operator in order for the Engineer to investigate the borrow area. The Engineer will determine

test locations, collect samples, and perform tests to investigate the proposed borrow area based on soil strata and required soil properties. The Engineer will approve use of materials from the proposed area based on test results and project requirements. Final acceptance of materials will be based on Point of Use Test as described in 6-1.2.4.

Before using any borrow material from any substitute areas, obtain the Engineer's approval, in writing, for the use of the particular areas, and, where applicable, ensure that the Engineer has cross-sectioned the surface. Upon such written approval by the Engineer, consider the substitute areas as designated borrow areas.

When furnishing the dredging or borrow areas, supply the Department with evidence that the necessary permits, rights, or waivers for the use of such areas have been secured.

Do not excavate any part of a Contractor furnished borrow area which is less than 300 feet from the right-of-way of the project or any State Road until the Engineer has approved a plan for landscaping and restoring the disturbed area. Perform this landscaping and land restoration at no expense to the Department, prior to final acceptance of the project. Do not provide a borrow area closer than 25 feet to the right-of-way of any state road. In Department furnished borrow pits, do not excavate material within 5 feet of adjacent property lines.

Upon completion of excavation, neatly shape, dress, grass, vegetate, landscape, and drain all exposed areas including haul roads, as necessary so as not to present an objectionable appearance.

Meet the requirements of Section 104 when furnishing borrow areas, regardless of location.

**120-6.3 Borrow Material for Shoulder Build-up:** When so indicated in the Plans, furnish borrow material with a specific minimum bearing value, for building up of existing shoulders. Blend materials as necessary to achieve this specified minimum bearing value prior to placing the materials on the shoulders. Take samples of this borrow material at the pit or blended stockpile. Include all costs of providing a material with the required bearing value in the Contract unit price for borrow material.

**120-6.4 Haul Routes for Borrow Pits:** Provide and maintain, at no expense to the Department, all necessary roads for hauling the borrow material. Where borrow area haul roads or trails are used by others, do not cause such roads or trails to deteriorate in condition.

Arrange for the use of all non-public haul routes crossing the property of any railroad. Incur any expense for the use of such haul routes. Establish haul routes which will direct construction vehicles away from developed areas when feasible, and keep noise from hauling operations to a minimum. Advise the Engineer in writing of all proposed haul routes.

**120-6.5 Authorization for Use of Borrow:** When the item of borrow excavation is included in the Contract, use borrow only when sufficient quantities of suitable material are not available from roadway and drainage excavation, to properly construct the embankment, subgrade, and shoulders, and to complete the backfilling of structures. Do not use borrow material until so ordered by the Engineer, and then only use material from approved borrow pits.

## **120-7 Materials for Embankment.**

**120-7.1 Use of Materials Excavated From the Roadway and Appurtenances:** Assume responsibility for determining the suitability of excavated material for use on the project in accordance with the applicable Contract Documents. Consider the sequence of work and maintenance of traffic phasing in the determination of the availability of this material.

**120-7.2 General Requirements for Embankment Materials:** Construct embankments of acceptable material including reclaimed asphalt pavement (RAP), reclaimed concrete aggregate (RCA) and portland cement concrete rubble, but containing no muck, stumps, roots, brush, vegetable matter, rubbish, reinforcement bar or other material that does not compact into a suitable and enduring roadbed. Do not use RAP or RCA in the top 3 feet of slopes and shoulders that are to be grassed or have other type of vegetation established.

Remove all waste material designated as undesirable. Use material in embankment construction in accordance with plan details or as the Engineer directs.

Complete the embankment using maximum particle sizes (in any dimension) as follows:

In top 12 inches: 3-1/2 inches (in any dimension).

12 to 24 inches: 6 inches (in any dimension).

In the depth below 24 inches: not to exceed 12 inches (in any dimension) or the compacted thickness of the layer being placed, whichever is less.

Spread all material so that the larger particles are separated from each other to minimize voids between them during compaction. Compact around these rocks in accordance with 120-9.2.

When and where approved by the Engineer, the Contractor may place larger rocks (not to exceed 18 inches in any dimension) outside the one to two slope and at least 4 feet or more below the bottom of the base. Compact around these rocks to a firmness equal to that of the supporting soil. Construct grassed embankment areas in accordance with 120-9.2.6. Where constructing embankments adjacent to bridge end bents or abutments, do not place rock larger than 3-1/2 inches in diameter within 3 feet of the location of any end-bent piling.

**120-7.3 Materials Used at Pipes, Culverts, etc.:** Construct embankments over and around pipes, culverts, and bridge foundations with selected materials.

## **120-8 Embankment Construction.**

**120-8.1 General:** Construct embankments in sections of not less than 300 feet in length or for the full length of the embankment. Perform work in accordance with an approved Quality Control (QC) Plan meeting the requirements of 105-3.

For construction of mainline pavement lanes, turn lanes, ramps, parking lots, concrete box culverts and retaining wall systems, a LOT is defined as a single lift of finished embankment not to exceed 500 feet.

For construction of shoulder-only areas, shared use paths, and sidewalks areas, a LOT is defined as a single lift of finished embankment not to exceed 2000 feet.

Isolated compaction operations will be considered as separate LOTS. For multiple phase construction, a LOT shall not extend beyond the limits of the phase.

### **120-8.2 Dry Fill Method:**

**120-8.2.1 General:** Construct embankments to meet compaction requirements in Article 120-9 and in accordance with the acceptance program requirements in 120-10. Restrict the compacted thickness of the last embankment lift to 6 inches maximum.

**120-8.2.1.1 For A-3, and A-2-4 Materials with up to 15% fines:** Construct the embankment in successive layers with lifts up to a maximum compacted thickness of 12 inches. Ensure the percentage of fines passing the No. 200 US Standard sieve in the A-2-4 material does not exceed 15%.

**120-8.2.1.2 For A-1, Plastic materials (As designated in Design Standard Index 505) and A-2-4 Materials with greater than 15% fines:** Construct the embankment in successive layers with lifts up to a maximum compacted thickness of 6 inches.

Alternately, for A-1, Plastic material and A-2-4 Materials with greater than 15% fines, construct embankments using thick lift construction in successive layers of not more than 12 inches compacted thickness, after having demonstrated with a successful test section, the possession and control of compacting equipment sufficient to achieve density required by 120-10.2 for the full depth of a thicker lift, and if the Engineer approves the compaction effort. Notify the Engineer prior to beginning construction of a test section. Construct a test section of the length of one full LOT. Perform five QC tests at random locations within the test section. All five QC tests and a Department Verification test must meet the density required by 120-10.2. Identify the test section with the compaction effort and soil classification in the Density Log Book. In case of a change in compaction effort or soil classification, failing QC test or when the QC tests cannot be verified, construct a new test section. The Contractor may elect to place material in 6 inches compacted thickness at any time. Construct all layers approximately parallel to the centerline profile of the road.

The Engineer reserves the right to terminate the Contractor's use of thick lift construction. Whenever the Engineer determines that the Contractor is not achieving satisfactory results, revert to the 6 inch compacted lifts.

As far as practicable, distribute traffic over the work during the construction of embankments so as to cover the maximum area of the surface of each layer.

Construct embankment in the dry whenever normal dewatering equipment and methods can accomplish the needed dewatering.

**120-8.2.1.3 Equipment and Methods:** Provide normal dewatering equipment including, but not limited to, surface pumps, sump pumps and trenching/digging machinery. Provide normal dewatering methods including, but not limited to, constructing shallow surface drainage trenches/ditches, using sand blankets, sumps and siphons.

When normal dewatering does not adequately remove the water, the Engineer may require the embankment material to be placed in the water or on low swampy ground in accordance with 120-9.2.3.

**120-8.2.2 Placing in Unstable Areas:** Where depositing the material in water, or on low swampy ground that will not support the weight of hauling equipment, construct the embankment by dumping successive loads in a uniformly distributed layer of a thickness not greater than necessary to support the hauling equipment while placing subsequent layers. Once sufficient material has been placed so that the hauling equipment can be supported, construct the remaining portion of the embankment in layers in accordance with the applicable provisions of 120-9.2.2 and 120-9.2.4.

**120-8.2.3 Placing on Steep Slopes:** When constructing an embankment on a hillside sloping more than 20 degrees from the horizontal, before starting the fill, deeply plow or cut into steps the surface of the original ground on which the embankment is to be placed.

**120-8.2.4 Placing Outside Standard Minimum Slope:** The standard minimum slope is defined as the plane described by a two (horizontal) to one (vertical) slope downward from the roadway shoulder line or the gutter line, as applicable. Where material that is unsuitable for normal embankment construction is to be used in the embankment outside the standard minimum slope, place such material in layers of not more than 18 inches in thickness, measured loose. The Contractor may also place material which is suitable for normal embankment, outside

such standard minimum slope, in 18 inch layers. Maintain a constant thickness for suitable material placed within and outside the standard minimum slope, unless placing in a separate operation.

**120-8.3 Hydraulic Method:**

**120-8.3.1 Method of Placing:** When the hydraulic method is used, as far as practicable, place all dredged material in its final position in the embankment by such method. Place and compact any dredged material that is rehandled, or moved and placed in its final position by any other method, as specified in 120-9.2. The Contractor may use baffles or any form of construction he may select provided the slopes of the embankments are not steeper than indicated in the Plans. Remove all timber used for temporary bulkheads or baffles from the embankment, and fill and thoroughly compact the holes thus formed. When placing fill on submerged land, construct dikes prior to beginning of dredging, and maintain the dikes throughout the dredging operation.

**120-8.3.2 Excess Material:** Do not use excess material placed outside the prescribed slopes, below the normal high-water level, to raise the fill. Remove only the portion of this material required for dressing the slopes.

**120-8.3.3 Protection of Openings in Embankment:** Leave openings in the embankments at the bridge sites. Remove any material which invades these openings or existing channels without additional compensation to provide the same depth of channel as existed before the construction of the embankment. Do not excavate or dredge any material within 200 feet of the toe of the proposed embankment.

**120-8.4 Reclaimed Asphalt Pavement (RAP) Method:**

**120-8.4.1 General:** Use only RAP material: 1) stored at facilities with an approved Florida Department of Environmental Protection Stormwater permit; or, 2) transferred directly from a milling project to the Department project. Certify the source if RAP material is from an identifiable Department project. Do not use RAP material in the following areas: 1) construction areas that are below the seasonal high groundwater table elevation; 2) MSE Wall backfill; 3) underneath MSE Walls or 4) the top 6 inches of embankment.

Prior to placement, submit documentation to the Engineer for his approval, outlining the proposed location of the RAP material.

**120-8.4.2 Soil and RAP Mixture:** Place the RAP material at the location and spread uniformly, using approved methods to obtain a maximum layer thickness of 4 inches. Mix this 4 inches maximum layer of RAP with a loose soil layer 8 to 10 inches thick. After mixing, meet all embankment utilization requirements of Design Standards, Index No. 505 for the location used. Do not mix RAP in the uppermost 12 inches in order to comply with 120-8.2.1. The total RAP and other embankment material shall not exceed 12 inches per lift after mixing and compaction if the contractor can demonstrate that the density of the mixture can be achieved. Perform mixing using rotary tillers or other equipment meeting the approval of the Engineer. The Engineer will determine the order in which to spread the two materials. Mix both materials to the full depth. Ensure that the finished layer will have the thickness and shape required by the typical section. Demonstrate the feasibility of this construction method by successfully completing a 500 foot long test section. For embankment construction, meet the requirements of 120-8. For compaction requirements of the soil and RAP mixture, meet the requirements of 120-9.

**120-8.4.3 Alternate Soil and RAP Layer Construction:** Construct soil in 6 to 12 inch compacted lifts and RAP in alternate layers with 6 inch maximum compacted lifts. Use soil with a minimum LBR value of 40 to prevent failure during compaction of the overlying RAP



layer. Demonstrate the feasibility of this construction method by successfully completing a 500 foot long test section. For compaction requirements of both soil and RAP, meet the requirements of 120-9.

### **120-9 Compaction Requirements.**

**120-9.1 Moisture Content:** Compact the materials at a moisture content such that the specified density can be attained. If necessary to attain the specified density, add water to the material, or lower the moisture content by manipulating the material or allowing it to dry, as is appropriate.

#### **120-9.2 Compaction of Embankments:**

**120-9.2.1 General:** Uniformly compact each layer, using equipment that will achieve the required density, and as compaction operations progress, shape and manipulate each layer as necessary to ensure uniform density throughout the embankment.

**120-9.2.2 Compaction Over Unstable Foundations:** Where the embankment material is deposited in water or on low swampy ground, and in a layer thicker than 12 inches (as provided in 120-8.2.2), compact the top 6 inches (compacted thickness) of such layer to the density as specified in 120-10.2.

**120-9.2.3 Compaction Where Plastic Material Has Been Removed:** Where unsuitable material is removed and the remaining surface is of the A-4, A-5, A-6, or A-7 Soil Groups (see AASHTO M-145), as determined by the Engineer, compact the surface of the excavated area by rolling with a sheepsfoot roller exerting a compression of at least 250 psi on the tamper feet, for the full width of the roadbed (subgrade and shoulders). Perform rolling before beginning any backfill, and continue until the roller feet do not penetrate the surface more than 1 inch. Do not perform such rolling where the remaining surface is below the normal water table and covered with water. Vary the procedure and equipment required for this operation at the discretion of the Engineer.

**120-9.2.4 Compaction of Material To Be Used In Base, Pavement, or Stabilized Areas:** Do not compact embankment material which will be incorporated into a pavement, base course, or stabilized subgrade, to be constructed as a part of the same Contract.

**120-9.2.5 Compaction of Grassed Shoulder Areas:** For the upper 6 inch layer of all shoulders which are to be grassed, since no specific density is required, compact only to the extent directed.

**120-9.2.6 Compaction of Grassed Embankment Areas:** For the outer layer of all embankments where plant growth will be established, do not compact. Leave this layer in a loose condition to a minimum depth of 6 inches for the subsequent seeding or planting operations.

**120-9.3 Compaction for Pipes, Culverts, etc.:** Compact the backfill of trenches to the densities specified for embankment or subgrade, as applicable, and in accordance with the requirements of 125-9.2.

Thoroughly compact embankments over and around pipes, culverts, and bridges in a manner which will not place undue stress on the structures, and in accordance with the requirements of 125-9.2.

**120-9.4 Compaction of Subgrade:** If the Plans do not provide for stabilizing, compact the subgrade (as defined in 1-3) in both cuts and fills, to the density specified in 120-10.2. For undisturbed soils, do not apply density requirements where constructing narrow widening strips or paved shoulders 5 feet or less in width.

Where trenches for widening strips are not of sufficient width to permit the use of standard compaction equipment, perform compaction using vibratory rollers, trench rollers, or other type compaction equipment approved by the Engineer.

Maintain the required density until the base or pavement is placed on the subgrade.

## **120-10 Acceptance Program.**

### **120-10.1 General Requirements:**

**120-10.1.1 Initial Equipment Comparison:** Before initial production, perform a comparison test using the QC, Verifications and Independent Assurance gauges. Unless the Engineer instructs, do not perform the initial equipment comparison more than once per project. When comparing the computed dry density of one nuclear gauge to a second gauge, ensure that the difference between the two computed dry densities does not exceed 2 lb/ft<sup>3</sup> between gauges from the same manufacturer, and 3 lb/ft<sup>3</sup> between gauges from different manufacturers. Repair or replace any QC gauge that does not compare favorably with the IA gauge.

Perform a comparison analysis between the QC nuclear gauge and the Verification nuclear gauge any time a nuclear gauge or repaired nuclear gauge is first brought to the project. Repair and replace any QC gauge that does not compare favorably with the Verification gauge at any time during the remainder of the project. Calibrate all QC gauges annually.

**120-10.1.2 Initial Production Lot:** Before construction of any other LOT, prepare a 500 foot initial control section consisting of one full LOT in accordance with the approved QC Plan for the project. Notify the Engineer at least 24 hours prior to production of the initial control section. Perform all QC tests required in 120-10.1.4. When the initial QC test results pass specifications, the Engineer will perform a Verification test to verify compliance with the specifications. Do not begin constructing another LOT until successfully completing the initial production LOT. The Engineer will notify the Contractor of the initial production lot approval within three working days after receiving the Contractor's QC data when test results meet the following conditions:

QC tests must meet the specifications.

Verification test must meet the specifications.

Difference between QC and Verification computed dry density results shall meet the requirements of 120-10.1.1.

If Verification test result fails the density requirements of 120-10.2, correct the areas of non-compliance. The QC and Verification tests will then be repeated. The Engineer will reject the Contractor's QC Plan after three unsuccessful Verification attempts. Submit a revised QC Plan to the Engineer for approval.

**120-10.1.3 Density over 105%:** When a QC computed dry density results in a value greater than 105% of the applicable Proctor maximum dry density, the Engineer will perform an Independent Verification density test within 5 feet. If the Independent Verification density results in a value greater than 105%, the Engineer will investigate the compaction methods, examine the applicable Standard Proctor Maximum Density and material description. The Engineer may collect and test an Independent Verification Standard Proctor Maximum Density sample for acceptance in accordance with the criteria of 120-10.2.

### **120-10.1.4 Quality Control (QC) Tests:**

**120-10.1.4.1 Standard Proctor Maximum Density Determination:**

Determine the QC standard Proctor maximum density and optimum moisture content by sampling and testing the material in accordance with the specified test method listed in 120-10.2.

**120-10.1.4.2 Density Testing Requirements:** Ensure compliance to the requirements of 120-10.2 by Nuclear Density testing in accordance with FM 1-T 238. Determine the in-place moisture content for each density test. Use FM 1-T 238, FM 5-507 (Determination of Moisture Content by Means of a Calcium Carbide Gas Pressure Moisture Tester), or ASTM D-4643 (Laboratory Determination of Moisture Content of Granular Soils by use of a Microwave Oven) for moisture determination.

**120-10.1.4.3 Soil Classification:** Perform soil classification tests on the sample collected in 120-10.1.4.1, in accordance with AASHTO T-88. Classify soils in accordance with AASHTO M-145 in order to determine compliance with embankment utilization requirements. Unless required by the Engineer, do not test or classify materials for stabilized subgrade or base.

**120-10.1.5 Department Verification:** The Engineer will conduct Verification tests in order to accept all materials and work associated with 120-10.1.4. The Engineer will verify the QC results if they meet the Verification Comparison Criteria, otherwise the Engineer will implement Resolution procedures.

The Engineer will select test locations, including Station, Offset, and Lift, using a Random Number generator based on the Lots under consideration. Each Verification test evaluates all work represented by the QC testing completed in those LOTS.

In addition to the Verification testing, the Engineer may perform additional Independent Verification (IV) testing. The Engineer will evaluate and act upon the IV test results in the same manner as Verification test results.

When the project requires less than four QC tests per material type, the Engineer reserves the right to accept the materials and work through visual inspection.

**120-10.1.6 Reduced Testing Frequency:** When no Resolution testing is required for 12 consecutive verified LOTS; or if required, the QC test data was upheld, reduce the QC density testing to one test every two LOTS by identifying the substantiating tests in the Density Log Book and notifying the Engineer in writing prior to starting reduced frequency of testing. Generate random numbers based on the two LOTS under consideration. When QC test frequency is reduced to one every two LOTS, obtain the Engineer's approval to place more than one LOT over an untested LOT. Assure similar compaction efforts for the untested LOTS. If the Verification test fails, and QC test data is not upheld by Resolution testing, the QC testing will revert to the original frequency of one QC test per LOT. Do not apply reduced testing frequency in construction of shoulder-only areas, shared use paths and sidewalks.

**120-10.1.7 Payment for Resolution Tests:** If the Resolution laboratory results compare favorably with the QC results, the Department will pay for Resolution testing. No additional compensation, either monetary or time, will be made for the impacts of any such testing.

If the Resolution laboratory results do not compare favorably with the QC results, the costs of the Resolution testing will be deducted from monthly estimates. No additional time will be granted for the impacts of any such testing.

**120-10.2 Acceptance Criteria:** Obtain a minimum QC density of 100% of the standard Proctor maximum density as determined by AASHTO T-99, Method C, with the following exceptions: 1) embankment constructed by the hydraulic method as specified in 120-8.3; 2)

material placed outside the standard minimum slope as specified in 120-8.2.4 except when a structure is supported on existing embankment; and, 3) other areas specifically excluded herein.

**120-10.3 Additional Requirements:**

**120-10.3.1 Frequency:** Conduct QC sampling and testing at a minimum frequency listed in the table below. The Engineer will perform Verification sampling and tests at a minimum frequency listed in the table below.

Test Name	Quality Control	Verification	Verification of Shoulder-Only Areas, Shared Use Paths, and Sidewalks
Standard Proctor Maximum Density	One per soil type	One per soil type	One per soil type
Density	One per LOT	One per four LOTS and for wet conditions, the first lift not affected by water	One per two LOTS
Soil Classification	One per Standard Proctor Maximum Density	One per Standard Proctor Maximum Density	One per Standard Proctor Maximum Density

**120-10.3.2 Test Selection and Reporting:** Determine test locations including Stations and offsets, using the random number generator approved by the Engineer. Do not use note pads or work sheets to record data for later transfer to the Density Log Book. Notify the Engineer upon successful completion of QC testing on each LOT.

**120-10.4 Verification Comparison Criteria and Resolution Procedures:**

**120-10.4.1 Standard Proctor Maximum Density Determination:** The Engineer will verify the QC results if the results compare within 4.5 lb/ft<sup>3</sup> of the Verification test result. Otherwise, the Engineer will take one additional sample of material from the soil type in question. The State Materials Office (SMO) or an AASHTO accredited laboratory designated by the SMO will perform Resolution testing. The material will be sampled and tested in accordance with AASHTO T-99, Method C.

The Engineer will compare the Resolution test results with the QC test results. If all Resolution test results are within 4.5 lb/ft<sup>3</sup> of the corresponding QC test results, the Engineer will use the QC test results for material acceptance purposes for each LOT with that soil type. If the Resolution test result is not within 4.5 lb/ft<sup>3</sup> of the Contractor's QC test, the Verification test result will be used for material acceptance purposes.

**120-10.4.2 Density Testing:** When a Verification or Independent Verification density test fails the Acceptance Criteria, retest the site within a 5 feet radius and the following actions will be taken:

1. If the QC retest meets the Acceptance Criteria and meets the 120-10.1.1 criteria when compared with the Verification or Independent Verification test, the Engineer will accept those LOTS.
2. If the QC retest does not meet the Acceptance Criteria and compares favorably with the Verification or Independent Verification test, rework and retest the LOT. The Engineer will re-verify those LOTS.

3. If the QC retest and the Verification or Independent Verification test do not compare favorably, complete a new comparison analysis as defined in 120-10.1.1. Once acceptable comparison is achieved, retest the LOTS. The Engineer will perform new verification testing. Acceptance testing will not begin on a new LOT until the Contractor has a gauge that meets the comparison requirements.

Record QC test results in the density log book on approved Department forms provided by the Engineer. Submit the original, completed density log book to the Engineer at final acceptance.

**120-10.4.3 Soil Classification:** The Engineer will verify the QC results if the Verification results identify matching soil classifications. Otherwise, the Engineer will take one additional sample of material from the soil type in question. The SMO or an AASHTO accredited laboratory designated by the SMO will perform Resolution testing. The material will be sampled and tested in accordance with AASHTO T-88.

The Engineer will compare the Resolution test results with the QC test results. If the Resolution test matches the QC classification, the Engineer will use the QC classification for material acceptance purposes. If the Resolution test result does not match the Contractor's QC classification, the Verification test result will be used for material acceptance purposes.

### **120-11 Maintenance and Protection of Work.**

While construction is in progress, maintain adequate drainage for the roadbed at all times. Maintain a shoulder at least 3 feet wide adjacent to all pavement or base construction in order to provide support for the edges.

Maintain all earthwork construction throughout the life of the Contract, and take all reasonable precautions to prevent loss of material from the roadway due to the action of wind or water. Repair, at no expense to the Department except as otherwise provided herein, any slides, washouts, settlement, subsidence, or other mishap which may occur prior to final acceptance of the work. Perform maintenance and protection of earthwork construction in accordance with Section 104.

Maintain all channels excavated as a part of the Contract work against natural shoaling or other encroachments to the lines, grades, and cross-sections shown in the Plans, until final acceptance of the project.

### **120-12 Construction.**

**120-12.1 Construction Tolerances:** Shape the surface of the earthwork to conform to the lines, grades, and cross-sections shown in the Plans. In final shaping of the surface of earthwork, maintain a tolerance of 0.3 foot above or below the plan cross-section with the following exceptions:

1. Shape the surface of shoulders to within 0.1 foot of the plan cross-section.
2. Shape the earthwork to match adjacent pavement, curb, sidewalk, structures, etc.
3. Shape the bottom of ditches so that the ditch impounds no water.
4. When the work does not include construction of base or pavement, shape the entire roadbed (shoulder point to shoulder point) to within 0.1 foot above or below the Plan cross-section.

Ensure that the shoulder lines do not vary horizontally more than 0.3 foot from the true lines shown in the Plans.

**120-12.2 Operations Adjacent to Pavement:** Carefully dress areas adjacent to pavement areas to avoid damage to such pavement. Complete grassing of shoulder areas prior to placing the final wearing course. Do not manipulate any embankment material on a pavement surface.

When shoulder dressing is underway adjacent to a pavement lane being used to maintain traffic, exercise extreme care to avoid interference with the safe movement of traffic.

### **120-13 Method of Measurement.**

**120-13.1 General:** When payment for excavation is on a volumetric basis, the quantity to be paid for will be the volume, in cubic yards, calculated by the method of average end areas, unless the Engineer determines that another method of calculation will provide a more accurate result. The material will be measured in its original position by field survey or by photogrammetric means as designated by the Engineer, unless otherwise specified under the provisions for individual items.

Where subsoil excavation extends outside the lines shown in the Plans or authorized by the Engineer including allowable tolerances, and the space is backfilled with material obtained in additional authorized roadway or borrow excavation, the net fill, plus shrinkage allowance, will be deducted from the quantity of roadway excavation or borrow excavation to be paid for, as applicable.

The quantity of all material washed, blown, or placed beyond the authorized roadway cross-section will be determined by the Engineer and will be deducted from the quantity of roadway excavation or borrow excavation to be paid for, as applicable.

Subsoil excavation that extends outside the lines shown in the Plans or authorized by the Engineer including allowable tolerances will be deducted from the quantity to be paid for as subsoil excavation.

**120-13.2 Roadway Excavation:** The measurement will include only the net volume of material excavated between the original ground surface and the surface of the completed earthwork, except that the measurement will also include all unavoidable slides which may occur in connection with excavation classified as roadway excavation.

The pay quantity will be the plan quantity provided that the excavation was accomplished in substantial compliance with the plan dimensions and subject to the provisions of 9-3.2 and 9-3.4. On designated 3-R Projects, regular excavation will be paid for at the Contract lump sum price provided that the excavation was accomplished in substantial compliance with the plan dimension.

**120-13.3 Borrow Excavation:** Measurement will be made on a loose volume basis, measured in trucks or other hauling equipment at the point of dumping on the road. If measurement is made in vehicles, level the material to facilitate accurate measurement.

Unsuitable material excavated from borrow pits where truck measurement is provided for and from any borrow pits furnished by the Contractor, will not be included in the quantity of excavation to be paid for.

**120-13.4 Lateral Ditch Excavation:** The measurement will include only material excavated within the lines and grades indicated in the Plans or as directed by the Engineer. The measurement will include the full station-to-station length shown in the Plans or directed by the Engineer and acceptably completed. Excavation included for payment under Section 125 will not be included in this measurement.

The pay quantity will be the plan quantity provided that the excavation was accomplished in substantial compliance with the plan dimensions and subject to the provisions of 9-3.2 and 9-3.4.

**120-13.5 Channel Excavation:** The measurement will include only material excavated within the lines and grades indicated in the Plans or in accordance with authorized Plan changes. The measurement will include the full station-to-station length shown in the Plans including any authorized changes thereto.

If shoaling occurs subsequent to excavation of a channel and the Engineer authorized the shoaled material to remain in place, the volume of any such material remaining within the limits of channel excavation shown in the Plans will be deducted from the measured quantity of channel excavation.

**120-13.6 Subsoil Excavation:** The measurement will include only material excavated within the lines and grades indicated in the Plans (including the tolerance permitted therefore) or as directed by the Engineer.

When no item for subsoil excavation is shown in the Contract but subsoil excavation is subsequently determined to be necessary, such unanticipated subsoil excavation will be paid for as provided in 4-4.

**120-13.7 Embankment:** The quantity will be at the plan quantity.

Where payment for embankment is not to be included in the payment for the excavation, and is to be paid for on a cubic yard basis for the item of embankment, the plan quantities to be paid for will be calculated by the method of average end areas unless the Engineer determines that another method of calculation will provide a more accurate result. The measurement will include only material actually placed above the original ground line, within the lines and grades indicated in the Plans or directed by the Engineer. The length used in the computations will be the station-to-station length actually constructed. The original ground line used in the computations will be as determined prior to placing of embankment subject to the provisions of 9-3.2, and no allowance will be made for subsidence of material below the surface of the original ground.

If there are authorized changes in plan dimensions or if errors in plan quantities are detected, plan quantity will be adjusted as provided in 9-3.2.

Where the work includes excavation of unsuitable material below the finished grading template or original ground line, whichever is lower as defined in 120-3.3, the original ground line is defined as the surface prior to beginning excavation, except that this surface is not outside the permissible tolerance of lines and grades for subsoil excavation as indicated in the Plans or as directed by the Engineer. Any overrun or underrun of plan quantity for subsoil excavation which results in a corresponding increase or decrease in embankment will be considered as an authorized plan change for adjustment purposes as defined in 9-3.2.2.

No payment will be made for embankment material used to replace unsuitable material excavated beyond the lines and grades shown in the Plans or ordered by the Engineer.

In no case will payment be made for material allowed to run out of the embankment on a flatter slope than indicated on the cross-section. The Contractor shall make his own estimate on the volume of material actually required to obtain the pay section.

## **120-14 Basis of Payment.**

**120-14.1 General:** Prices and payments for the various work items included in this Section will be full compensation for all work described herein, including excavating, dredging,

hauling, placing, and compacting; dressing the surface of the earthwork; maintaining and protecting the complete earthwork; and hauling.

The Department will not allow extra compensation for any rehandling of materials.

The Department will compensate for the cost of grassing or other permanent erosion control measures directed by the Engineer as provided in the Contract for similar items of roadway work.

**120-14.2 Excavation:**

**120-14.2.1 Items of Payment:** When no classification of material is indicated in the Plans, and bids are taken only on regular excavation, the total quantity of all excavation specified under this Section will be paid for at the Contract unit price for regular excavation.

When separate classifications of excavation are shown in the proposal, the quantities of each of the various classes of materials so shown will be paid for at the Contract unit prices per cubic yard for regular excavation, lateral ditch excavation, subsoil excavation, and channel excavation, as applicable, and any of such classifications not so shown will be included under the item of regular excavation (except that if there is a classification for lateral ditch excavation shown and there is no classification for channel excavation, any channel excavation will be included under the item of lateral ditch excavation). As an exception on designated projects, regular excavation will be paid for at the Contract lump sum price.

**120-14.2.2 Basic Work Included in Payments:** Prices and payments will be full compensation for all work described under this Section, except for any excavation, or embankment which is specified to be included for payment under other items. Such prices and payments will include hauling; any rehandling that may be necessary to accomplish final disposal as shown in the Plans; the dressing of shoulders, ditches and slopes; removal of trash, vegetation, etc., from the previously graded roadway where no item for clearing and grubbing is shown in the Plans; and compacting as required.

**120-14.2.3 Additional Depth of Subsoil Excavation:** Where subsoil excavation is made to a depth of 0 to 5 feet below the depth shown in the Plans, such excavation will be paid for at the unit price bid.

Where subsoil excavation is made to a depth greater than 5 feet, and up to 15 feet, deeper than the depth shown in the Plans, such excavation will be paid for at the unit price bid plus 25% of such unit price. Additional extra depth, more than 15 feet below such plan depth, will be considered as a change in the character of the work and will be paid for as unforeseeable work.

Where no subsoil excavation is shown in a particular location on the original Plans, payment for extra depth of subsoil will begin 5 feet below the lowest elevation on the grading template.

**120-14.2.4 Borrow Excavation:** When the item of borrow excavation is included in the Contract, price and payment will also include the cost of furnishing the borrow areas and any necessary clearing and grubbing thereof, the removal of unsuitable material that it is necessary to excavate in order to obtain suitable borrow material, and also the costs incurred in complying with the provisions of 120-6.3.

**120-14.2.5 Materials Excluded from Payment for the Excavation:** No payment for excavation will be made for any excavation covered for payment under the item of embankment.



No payment will be made for the excavation of any materials which is used for purposes other than those shown in the Plans or designated by the Engineer. No payment will be made for materials excavated outside the lines and grades given by the Engineer, unless specifically authorized by the Engineer. As an exception, in operations of roadway excavation, all slides and falls of insecure masses of material beyond the regular slopes that are not due to lack of precaution on the part of the Contractor, will be paid for at the Contract unit price for the material involved. The removal of slides and falls of material classified as lateral ditch excavation or as subsoil excavation will not be paid for separately, but will be included in the Contract unit price for the pay quantity of these materials, measured as provided in 120-14.

**120-14.3 Embankment:**

**120-14.3.1 General:** Price and payment will be full compensation for all work specified in this Section, including all material for constructing the embankment, all excavating, dredging, pumping, placing and compacting of material for constructing the embankment complete, dressing of the surface of the roadway, maintenance and protection of the completed earthwork, and the removal of rubbish, vegetation, etc., from the roadway where no clearing and grubbing of the area is specified in the Plans. Also, such price and payment, in each case, will specifically include all costs of any roadway, lateral ditch, or channel excavation, unless such excavation is specifically shown to be paid for separately, regardless of whether the materials are utilized in the embankment.

**120-14.3.2 Excluded Material:** No payment will be made for the removal of muck or overburden from the dredging or borrow areas. No payment will be made for embankment material used to replace muck or other unsuitable material excavated beyond the lines and grades shown in the Plans or ordered by the Engineer.

**120-14.3.3 Clearing and Grubbing:** No payment will be made for any clearing and grubbing of the borrow or dredging areas. Where no clearing and grubbing of such areas is specified in the Plans, the cost of any necessary clearing and grubbing will be included in the Contract unit or lump sum price for Embankment.

**120-14.3.4 Cost of Permits, Rights, and Waivers:** Where the Contractor provides borrow or dredging areas of his own choosing, the cost of securing the necessary permits, rights or waivers will be included in the Contract price for embankment.

**120-14.4 Payment Items:** Payment will be made under:

- |                   |   |
|-------------------|---|
| Item No. 120- 1-  | Regular Excavation - per cubic yard.          |
| Item No. 120- 2-  | Borrow Excavation - per cubic yard.           |
| Item No. 120- 3-  | Lateral Ditch Excavation - per cubic yard.    |
| Item No. 120- 4-  | Subsoil Excavation - per cubic yard.          |
| Item No. 120- 5-  | Channel Excavation - per cubic yard.          |
| Item No. 120- 6-  | Embankment - per cubic yard.                  |
| Item No. 120- 71- | Regular Excavation (3-R Projects) - lump sum. |

## **SECTION 125 EXCAVATION FOR STRUCTURES AND PIPE**

### **125-1 Description.**

Excavate for box culverts, pipes, retaining walls, headwalls for pipes and drains, catch basins, drop inlets, manholes, and similar structures. Construct and remove cofferdams, sheeting, bracing, etc.; pump or otherwise dewater foundations; remove and dispose of any existing structures or portions of structures not covered by other items in the Contract, including foundations, abutments, piers, wings, and all other materials, obstructions, etc., found necessary to clear the site for the proposed work; backfill, dispose of surplus material, and perform final cleaning, as may be necessary for the proper execution of the work. This Section does not include excavation for bases or pavements, curbs, curb and gutter, valley gutter, ditch pavement, or rubble gutter. Perform work in accordance with an approved Quality Control (QC) Plan meeting the requirements of 105-3.

**125-1.1 Trench Excavation Safety System and Shoring, Special (Trench Excavation):** When performing trench excavation in excess of 5 feet in depth, comply with the Occupational Safety and Health Administration's (OSHA) trench safety standards, 29 CFR, 1926, Subpart P, and all subsequent revisions or updates adopted by the Department of Labor and Employment Security. Ensure that trench boxes are wide enough to accommodate compaction and density testing.

Submission of bid and subsequent execution of the Contract will serve as certification that all trench excavation in excess of 5 feet in depth will be in compliance with Section 553.62, Florida Statutes.

Consider all available geotechnical information when designing the trench excavation safety system.

Consider these and any more stringent trench safety standards as minimum Contract requirements.

### **125-2 Classification.**

Consider all materials excavated as unclassified and as excavation regardless of the material encountered.

### **125-3 Cofferdams.**

#### **125-3.1 Construction:**

**125-3.1.1 Methods:** Construct all foundations by open excavation, and shore, brace, or protect the foundation openings with cofferdams. Provide cofferdams or cribs for foundation construction below the bottom of the footings. Provide sufficient clearance in the cofferdam interiors to permit construction of forms and inspection of their exteriors, and for pumping equipment.

**125-3.1.2 Protection of Concrete:** Construct cofferdams to protect green concrete against damage from a sudden rising of the water and to prevent damage by erosion. Do not leave timber or bracing in cofferdams or cribs that extend into the substructure masonry except where permitted in writing by the Engineer.

**125-3.1.3 Placing in the Dry:** For placing footings in the dry, the Engineer may require cofferdam sheeting to be driven to an elevation 6 feet below the elevation of the bottom

of the footings and require sufficient pumping equipment to dewater and maintain the cofferdam in a comparatively dry condition.

**125-3.1.4 Working Drawings:** For substructure work, submit drawings showing the proposed method of cofferdam construction and other details left to choice or not fully shown in the Plans. Obtain the Engineer's approval of the type and clearance of cofferdams, insofar as such details affect the character of the finished work. For other details of design that do not affect the character of the finished work, assume responsibility for the successful construction of the work. Retain a Professional Engineer, registered in the State of Florida, to prepare the above construction drawing, and keep a signed and sealed copy on hand at the site at all times.

**125-3.2 Removal:** Unless otherwise provided, remove cofferdams or cribs, with all sheeting and bracing, after completion of the substructure without disturbing or marring the finished masonry.

#### **125-4 Excavation.**

**125-4.1 Requirements for all Excavation:** Perform all excavation to foundation materials, satisfactory to the Engineer, regardless of the elevation shown in the Plans. Remove rock, boulders or other hard lumpy or unyielding material to a depth of 12 inches below the bottom of pipes and box culverts elevations. Remove muck or other soft material to the depth indicated in the Plans or as directed by the Engineer.

##### **125-4.2 Earth Excavation:**

**125-4.2.1 Foundation Material other than the Rock:** When masonry is to rest on an excavated surface other than rock, take special care to avoid disturbing the bottom of the excavation, and do not remove the final foundation material to grade until just before placing the masonry. In case the foundation material is soft or mucky, the Engineer may require excavation to a greater depth and to backfill to grade with approved material.

**125-4.2.2 Foundation Piles:** Where foundation piles are used, complete the excavation of each pit before driving the piles. After the driving is completed, remove all loose and displaced material, leaving a smooth, solid, and level bed to receive the masonry.

**125-4.2.3 Removal of Obstructions:** Remove boulders, logs, or any unforeseen obstacles encountered in excavating. Compensation will be in accordance with the requirements of 4-3.

**125-4.3 Rock Excavation:** Clean all rock and other hard foundation material, remove all loose material, and cut all rock to a firm surface. Either level, step vertically and horizontally, or serrate the rock, as may be directed by the Engineer. Clean out all seams, and fill them with concrete or mortar.

**125-4.4 Pipe Trench Excavation:** Excavate trenches for pipes to the elevation of the bottom of the pipe and to a width sufficient to provide adequate working room. Remove soil not meeting the classification specified as suitable backfill material in 125-8.3.2.2, to a depth of 4 inches below the bottom of the pipe elevation. Where the soils permit, ensure that the trench sides are vertical up to at least the mid-point of the pipe.

For pipe lines placed above the natural ground line, place and compact the embankment, prior to excavation of the trench, to an elevation at least 2 feet above the top of the pipe and to a width equal to four pipe diameters, and then excavate the trench to the required grade.

For pipe trenches utilizing trench boxes, ensure that the trench box used is of sufficient width to permit thorough tamping of bedding material under and around the pipes as specified in 125-8.1.6.

Do not disturb the installed pipe and its embedment when moving trench boxes. Move the trench box carefully to avoid excavated wall displacement or damage. As the trench box is moved, fill any voids left by the trench box and continuously place and compact the backfill material adjacent to and all along the side of the trench box walls to fill any voids created by the trench box.

### **125-5 Preservation of Channel.**

**125-5.1 General:** Unless shown in the Plans, do not excavate outside of caissons, cribs, cofferdams, or sheet piling, and do not disturb the natural stream bed adjacent to the structure. If excavating or dredging at the site of the structure before sinking caissons, cribs, or cofferdams, complete the foundation and backfill all such excavations to the original ground surface or other required elevation, with material satisfactory to the Engineer.

**125-5.2 Removal of Excavated Materials:** Do not allow materials that are deposited adjacent to the stream area to infiltrate the water areas. Leave the stream in its original condition.

### **125-6 Disposal of Surplus.**

Use suitable excavated materials for backfilling over or around the structure. Dispose of unsuitable materials. Meet the disposal requirements pertaining to water pollution contained in Section 104 and in 7-1.1.

### **125-7 Pumping.**

Pump from the interior of any foundation enclosure in such manner as to preclude the possibility of any portion of the concrete materials being carried away. Do not pump while placing concrete, or for a period of at least 24 hours thereafter, unless using a suitable pump separated from the concrete work by a watertight wall.

### **125-8 Backfilling.**

#### **125-8.1 General Requirements for Structures and Pipe:**

**125-8.1.1 General:** Backfill in the dry whenever normal dewatering equipment and methods can accomplish the needed dewatering. A LOT is defined as one lift of backfill material placement, not to exceed 500 feet in length or a single run of pipe connecting two successive structures, whichever is less. Backfill for structures and pipe compacted in one operation will be considered as one LOT within the cover zone. Backfill around structures compacted separately from the pipe will be considered as separate LOTs. Backfill on each side of the pipe for the first lift will be considered a separate LOT. Backfill on opposite sides of the pipe for the remaining lifts will be considered separate LOTs, unless the same compactive effort is applied. Same compactive effort is defined as the same type of equipment (make and model) making the same number of passes on both sides of the pipe. For multiple phase backfill, a LOT shall not extend beyond the limits of the phase.

When placing backfill within trench box each lift of backfill is considered a LOT. Placement of backfill within trench box limits will be considered a complete operation before trench box is moved for next backfill operation. When the trench box is moved for next backfill operation this will start new LOTs for each lift. Follow the density testing frequency in 125-9.3.1.

**125-8.1.2 Equipment and Methods:** Provide normal dewatering equipment including, but not limited to, surface pumps, sump pumps, wellpoints and header pipe and trenching/digging machinery. Provide normal dewatering methods including, but not limited to,

constructing shallow surface drainage trenches/ditches, using sand blankets, perforated pipe drains, sumps and siphons.

**125-8.1.3 Backfill Materials:** Backfill to the original ground surface or subgrade surface of openings made for structures, with a sufficient allowance for settlement. The Engineer may require that the material used for this backfill be obtained from a source entirely apart from the structure. Use only material accepted by the Engineer.

Do not allow heavy construction equipment to cross over culvert or storm sewer pipes until placing and compacting backfill material to the finished earthwork grade or to an elevation at least 4 feet above the crown of the pipe.

**125-8.1.4 Use of A-7 Material:** In the backfilling of trenches, A-7 material may be used from a point 12 inches above the top of the pipe up to the elevation shown in the Design Standards as the elevation for undercutting of A-7 material.

**125-8.1.5 Time of Placing Backfill:** Do not place backfill against any masonry or concrete abutment, wingwall, or culvert until the Engineer has given permission to do so, and in no case until the masonry or concrete has been in place seven days or until the specified 28 day compressive strength occurs.

**125-8.1.6 Placement and Compaction:** Place the material in horizontal layers not exceeding 6 inches compacted thickness, in depth above water level, behind abutments, wingwalls and end bents or end rest piers, under the haunches of the pipes and around box culverts and all structures including pipe culverts. When the backfill material is deposited in water, compact as specified in 125-8.2.5 and 125-8.3.4.

The Contractor may elect to place material in thicker lifts of no more than 12 inches compacted thickness above the Soil Envelope if he can demonstrate with a successful test section that density can be achieved. Notify the Engineer prior to beginning construction of a test section. Construct a test section of the length of one LOT. Perform five QC tests at random locations within the test section. All five tests must meet the density required by 125-9.2 and be verified by the Department. Identify the test section with the compaction effort and soil classification in the Logbook. In case of a change in compaction effort or soil classification, construct a new test section. When a QC test fails the requirements of 125-9.2 or when the QC tests cannot be verified, construct a new test section. The Contractor may elect to place material in 6 inches compacted thickness at any time.

### **125-8.2 Additional Requirements for Structures Other than Pipe:**

**125-8.2.1 Density:** Where the backfill material is deposited in water, obtain a 12 inch layer of comparatively dry material, thoroughly compacted by tamping, before verifying the layer and density requirements. Meet the requirements of 125-9.2.

**125-8.2.2 Box Culverts:** For box culverts over which pavement is to be constructed, compact around the structure to an elevation not less than 12 inches above the top of the structure, using rapid-striking mechanical tampers.

**125-8.2.3 Other Limited Areas:** Compact in other limited areas using mechanical tampers or approved hand tampers, until the cover over the structure is at least 12 inches thick. When hand tampers are used, deposit the materials in layers not more than 4 inches thick using hand tampers suitable for this purpose with a face area of not more than 100 square inches. Take special precautions to prevent any wedging action against the masonry, and step or terrace the slope bounding the excavation for abutments and wingwalls if required by the Engineer.

**125-8.2.4 Culverts and Piers:** Backfill around culverts and piers on both sides simultaneously to approximately the same elevation.

**125-8.2.5 Compaction Under Wet Conditions:** Where wet conditions do not permit the use of mechanical tampers, compact using hand tampers. Use only A-3 material for the hand tamped portions of the backfill. When the backfill has reached an elevation and condition such as to make the use of the mechanical tampers practical, perform mechanical tamping in such manner and to such extent as to transfer the compaction force into the sections previously tamped by hand.

**125-8.3 Additional Requirements for Pipe 15 Inches Inside Diameter or Greater:**

**125-8.3.1 General:** Trenches for pipe may have up to four zones that must be backfilled.

**Lowest Zone:** The lowest zone is backfilled for deep undercuts up to within 4 inches of the bottom of the pipe.

**Bedding Zone:** The zone above the lowest zone is the bedding zone. Usually it will be the backfill which is the 4 inches of soil below the bottom of the pipe. When rock or other hard material has been removed to place the pipe, the bedding zone will be the 12 inches of soil below the bottom of the pipe.

**Cover Zone:** The next zone is backfill that is placed after the pipe has been laid and will be called the cover zone. This zone extends to 12 inches above the top of the pipe. The cover zone and the bedding zone are considered the Soil Envelope for the pipe.

**Top Zone:** The top zone extends from 12 inches above the top of the pipe to the base or final grade.

**125-8.3.2 Material:**

**125-8.3.2.1 Lowest Zone:** Backfill areas undercut below the bedding zone of a pipe with coarse sand, or other suitable granular material, obtained from the grading operations on the project, or a commercial material if no suitable material is available.

**125-8.3.2.2 Soil Envelope:** In both the bedding zone and the cover zone of the pipe, backfill with materials classified as A-1, A-2, or A-3. Material classified as A-4 may be used if the pipe is concrete pipe.

**125-8.3.2.3 Top Zone:** Backfill the area of the trench above the soil envelope of the pipe with materials allowed on Design Standards, Index No. 505.

**125-8.3.3 Compaction:**

**125-8.3.3.1 Lowest Zone:** Compact the soil in the lowest zone to approximately match the density of the soil in which the trench was cut.

**125-8.3.3.2 Bedding Zone:** If the trench was not undercut below the bottom of the pipe, loosen the soil in the bottom of the trench immediately below the approximate middle third of the outside diameter of the pipe.

If the trench was undercut, place the bedding material and leave it in a loose condition below the middle third of the outside diameter of the pipe. Compact the outer portions to meet the density requirements of the acceptance criteria. Place the material in lifts no greater than 6 inches (compacted thickness).

**125-8.3.3.3 Cover Zone:** Before placing the cover zone material, lay pipe according to Section 430. Excavate for pipe bells before laying pipe. Place the material in 6 inch layers (compacted thickness), evenly deposited on both sides of the pipe, and compact with mechanical tampers suitable for this purpose. Hand tamp material below the pipe haunch that cannot be reached by mechanical tampers. Meet the requirements of in 125-9.2.

**125-8.3.3.4 Top Zone:** Place the material in layers not to exceed 12 inches in compacted thickness. Meet the requirements of the density acceptance criteria.

**125-8.3.4 Backfill Under Wet Conditions:** Where wet conditions are such that dewatering by normal pumping methods would not be effective, the procedure outlined below may be used when specifically authorized by the Engineer in writing. The Department will pay for any select material which is not available from the grading as Unforeseeable Work. The Department will not pay for select material that might be used by the Contractor for his own convenience instead of dewatering.

The Department will permit the use of granular material below the elevation at which mechanical tampers would be effective, but only material classified as A-3. Place and compact the material using timbers or hand tampers until the backfill reaches an elevation such that its moisture content will permit the use of mechanical tampers. When the backfill has reached such elevation, use normally acceptable backfill material. Compact the material using mechanical tampers in such manner and to such extent as to transfer the compacting force into the material previously tamped by hand.

The Department will permit the use of coarse aggregate below the elevation at which mechanical tampers would be effective. Use coarse aggregate as specified in Section 901 for Aggregate Size Number 89, 8, 78, 7, 68, 6, or 57. Place the coarse aggregate such that it will be stable and firm. Fully wrap the aggregate with a layer of Type D-4 filter fabric, as specified in Section 985. Do not place coarse aggregate within 4 feet of the ends of the trench or ditch. Use normally accepted backfill material at the ends.

## **125-9 Acceptance Program.**

**125-9.1 General Requirements:** Meet the requirements of 120-10, except replace the requirements of 120-10.1.6 with 125-9.1.1, 120-10.2 with 125-9.2, 120-10.3 with 125-9.3, and 120-10.4 with 125-10.

**125-9.1.1 Reduced Testing Frequency:** When no resolution testing is required for six consecutive LOTs, or if required, the QC test data was upheld, reduce the QC density testing to one test every two LOTs or one every four LOTs for trench box operations. Identify the substantiating tests in the Density Log Book and notify the Engineer in writing prior to starting reduced frequency of testing. Generate random numbers for selecting test locations for the LOTs under consideration. When QC test frequency is reduced to one every two LOTs, obtain the Engineer's approval to place more than one LOT over an untested LOT. Assure similar compaction efforts for the untested sections. If the Verification test fails, and QC test data is not upheld by Resolution testing the QC testing will revert to the original frequency.

### **125-9.2 Acceptance Criteria:**

**125-9.2.1 Density:** Obtain a minimum QC density in any LOT of 100% of the Standard Proctor maximum density as determined by AASHTO T99, Method C, or the requirements of 125-8.3.3.1 when applicable. When the cover height below the bottom of base under asphalt pavement, below concrete pavement, or below unpaved ground, exceeds 15 inches, compact the pipe backfill in the cover zone to a density of at least 95% of the Standard Proctor maximum density as determined by AASHTO T99, Method C.

For density requirements around drainage structures, obtain a minimum Quality Control (QC) density in any LOT of 100% of the Standard Proctor maximum density as determined by AASHTO T99 for a distance of one pipe diameter but not less than 3 feet from the outside face of the structure.

**125-9.2.2 Exceptions to Structures and Pipe Density Requirements:** Compact the backfill to a firmness approximately equal to that of the soil next to the pipe trench in locations outside the plane described by a two (horizontal) to one (vertical) slope downward from the roadway shoulder line or the gutter line as applicable. Apply 125-9.2.1 when compacting side-drain pipe backfill under driveways serving a property that is not a single residential lot.

**125-9.3 Additional Requirements:**

**125-9.3.1 Frequency:** Conduct QC Standard Proctor maximum density sampling and testing at a minimum frequency of one test per soil type. The verification test will be at a minimum of one test per soil type:

Test Name	Quality Control	Verification
Standard Proctor Maximum Density	One per soil type	One per soil type
Density	One per LOT	One per four consecutive LOTs and for wet conditions, the first lift not affected by water
Soil Classification	One per Standard Proctor Maximum density	One per Standard Proctor Maximum density

**125-10 Verification Comparison Criteria and Resolution Procedures.**

**125-10.1 Standard Proctor Maximum Density Determination:** The Engineer will verify the QC results if the results compare within 4.5 PCF of the verification test result. Otherwise, the Engineer will take one additional sample of material from the soil type in question. The State Materials Office or an AASHTO accredited laboratory designated by the State Materials Office will perform resolution testing. The material will be sampled and tested in accordance with AASHTO T99, Method C.

The Engineer will compare the resolution test result with the QC test results. If the resolution test result is within 4.5 PCF of the corresponding QC test results, the Engineer will use the QC test results for material acceptance purposes for each LOT with that soil type. If the resolution test result is not within 4.5 PCF of the Contractor’s QC test, the verification test result will be used for material acceptance purposes.

**125-10.2 Density Testing:** When a verification or independent verification density test fails the acceptance criteria, retest the site within a 5 feet radius and the following actions will be taken:

1. If the QC retest meets the acceptance criteria and compares favorably with the verification or independent verification test, the Engineer will accept those LOTs.
2. If the QC retest does not meet the acceptance criteria and compares favorably with the verification or independent verification test, rework and retest the LOT. The Engineer will re-verify those LOTs.
3. If the QC retest and the verification or independent verification test do not compare favorably, complete a new equipment-comparison analysis as defined in 120-10.1.2. Once acceptable comparison is achieved, retest the LOTs. The Engineer will perform new verification testing. Acceptance testing will not begin on a new LOT until the Contractor has a gauge that meets the comparison requirements.

**125-10.3 Soil Classification:** Meet the requirements of 120-10.4.3.



### **125-11 Site Restoration.**

Wherever the existing site is disturbed solely for the purpose of constructing or removing box culverts, pipes, inlets, manholes, etc., completely replace and restore the site to the Engineer's satisfaction, without additional compensation.

### **125-12 Cleaning Up.**

Upon completion of the work, leave the structure and all adjacent areas in a neat and presentable condition, clear up all temporary structures, rubbish and surplus materials and leave the space under the structure unobstructed and in such shape that drift will not collect nor scour or be induced. Pile all material from existing structures that have been removed neatly on the bank, unless otherwise directed by the Engineer. Pull false work piling unless the Engineer permits it to be cut or broken off in which case it will be cut or broken off at least 2 feet below the ground line or stream bed.

### **125-13 Method of Measurement.**

When direct payment for excavation for structures is provided in the proposal, and such payment is on a unit basis, such excavation will be measured in its original position by the cross-section method to determine the amount of material. The cubic yard volume of excavation used as a basis of payment will then be that material actually removed below the original ground line or stream bed, but not including that shown in the Plans to be paid for either as regular excavation, subsoil excavation, lateral ditch excavation or channel excavation, or which is included in the item for grading, and except that no payment will be made for material removed in excavating for footings or foundations outside of an area which is bounded by vertical planes 12 inches outside of the limits of the footing and parallel thereto. For pipe trenches the width used to be in the calculation shall be the diameter of the pipe, plus 24 inches.

### **125-14 Basis of Payment.**

**125-14.1 When No Direct Payment Provided:** When direct payment for excavation for structures is not provided for in the proposal, all work specified in this Section, other than as specified in 125-14.3 through 125-14.7, shall be included in the Contract price for the concrete or for other items covering the applicable structure.

**125-14.2 Direct Payment:** When direct payment for work under this Section is provided, the Contract price per cubic yard (measured as provided in 125-13), as shown in the proposal, shall be full compensation for all the work specified in this Section, except such work as is specifically stipulated to be paid for separately, in 125-14.3 through 125-14.7.

**125-14.3 Excavation Below Plan Grade:** When excavation of material below plan grade is called for in the Plans or authorized by the Engineer, and payment for Excavation for Structures is on a cubic yard basis, the material excavated below plan grade will be included in the measurement for this item.

Payment for the material used for the backfill will be made as specified in 125-14.7.

**125-14.4 Strengthening Foundations:** The work of strengthening the foundations (as provided in 125-4.2) shall be paid for as provided in 4-4, unless such work is covered by a bid item.

**125-14.5 Backfilling for Additional Support:** The work of providing additional support by backfilling with sand or other satisfactory material, where called for by the Engineer (as specified in 125-8), shall be paid for as provided in 4-4.

**125-14.6 Removal and Replacement of Existing Pavement:** For pavement, curb, etc., which is removed only in order to construct pipe culverts or storm sewers, as specified in 125-11, all costs of such removal and replacement shall be included in the costs of the pipe or other structure for which it is removed, unless otherwise provided for in the contract.

**125-14.7 Removal and Replacement of Material Unsuitable for Backfill:** When it cannot reasonably be anticipated from information contained in the Plans, that material excavated for the structure will be unsuitable for use as backfill, and such material proves to be unsuitable for this use, the work of disposing of such material away from the site will be paid for as Unforeseeable Work, and the work of bringing in substitute material for the backfill will be paid for as specified for the particular case shown below:

(a) No additional payment will be made for backfill materials obtained from surplus material available from the normal excavation or grading operations.

(b) When the necessary material is not available from the normal excavation or grading operations, and the Contract includes an item for borrow excavation, backfill material authorized to be obtained from designated borrow areas will be included in the volume of borrow excavation to be paid for.

(c) When the necessary material is not available from the normal excavation or grading operations and no separate item for borrow excavation is included in the Contract, any backfill material obtained by increasing the volume of excavation within the roadway right of way will be measured and paid for as regular excavation subject to the provisions of 9-3.2.2.

(d) When authorization is given for obtaining the material from outside the right of way and from other than designated borrow areas, such excavation will be paid for as unforeseeable work.

(e) Where pipe bedding is provided, as specified in 125-8, by the use of select granular material, the quantity of such select material obtained either as commercial material or from material from the grading operations other than in the immediate vicinity of the pipe to be bedded, as authorized by the Engineer, will be paid for at the Contract price per cubic yard for select bedding material. No payment for this material will be made for material available from the excavation for the pipe culvert or from other material available from the grading operations at a location not sufficiently remote as to require loading on trucks.

**125-14.8 Pay Items:** Payment for the work under this Section, when provided for directly, shall be made under:

Item No. 125- 1- Excavation for Structures - per cubic yard.

Item No. 125- 3- Select Bedding Material - per cubic yard.

## **SECTION 160 STABILIZING**

### **160-1 Description.**

Stabilize designated portions of the roadbed to provide a firm and unyielding subgrade, having the required bearing value specified in the Plans. Perform work in accordance with an approved Quality Control (QC) Plan meeting the requirements of Section 105.

### **160-2 Materials.**

**160-2.1 Commercial Material:** Meet the requirements of Section 914.

**160-2.2 Local Material:** Meet the requirements of Section 914. Test material from each source, or if authorized by the Engineer, test blended materials. Submit test results to the Engineer at least 14 days prior to the stabilization operation.

**160-2.3 Existing Base:** When the material from an existing base is used as all, or a portion, of the stabilizing additives, no further testing is required unless directed by the Engineer.

**160-2.4 Granular Subbase:** The Engineer may allow, at no additional cost to the Department, the substitution of 6 inches of granular subbase meeting the requirements of 290-2 and 290-3, when 12 inches of stabilization requiring a limerock bearing ratio (LBR) value of 40 is specified.

### **160-3 Construction Methods.**

**160-3.1 General:** Prior to the beginning of stabilizing operations, construct the area to be stabilized to an elevation such that, upon completion of stabilizing operations, the completed stabilized subgrade will conform to the lines, grades, and cross-section shown in the Plans. Prior to spreading any additive stabilizing material, bring the surface of the roadbed to a plane approximately parallel to the plane of the proposed finished surface.

Construct mainline pavement lanes, turn lanes, ramps, parking lots, concrete box culverts and retaining wall systems meeting the requirements of 120-8.1, except replace “embankment” with “subgrade”.

Construct shoulder-only areas, sidewalk, and shared use path areas meeting the requirements of 120-8.1 except replace “embankment” with “subgrade” and meet the acceptance criteria of 160-4.2.

Isolated mixing operations will be considered as separate LOTs. Curb pads and shoulders compacted separately shall be considered separate LOTs. Isolated compaction operations will be considered as separate LOTs. For multiple phase construction, a LOT shall not extend beyond the limits of the phase.

**160-3.2 Application of Stabilizing Material:** After substantially completing the roadbed grading operations, determine the type and quantity (if any) of stabilizing material necessary for compliance with the bearing value requirements. Before using any Fossil Fuel Combustion Products (FFCPs), provide documentation, at the preconstruction meeting or no later than 30 days prior to delivery of FFCP’s to the project, signed and sealed by the Specialty Engineer that these materials meet the requirements of 403.7047 F.S. Notify the Engineer of the approximate quantity to be added before spreading. When additive stabilizing materials are required, spread the material uniformly over the area to be stabilized.

**160-3.2.1 Sampling and Testing of Local Material:** Randomly select locations for sampling using a random number generator approved by the Engineer in accordance with

FM 1-T 267 and test at the minimum frequency listed in the table below before mixing. The Engineer will reject the material for failing QC test results. The Engineer will sample for Verification and Resolution testing at the minimum frequency listed in the table below. The Engineer will perform Verification tests at the minimum frequency listed in the table below.

Test Name	Quality Control	Verification	Resolution
Liquid Limit (LL), Plastic Index (PI), and Organic Content	One per two LOTs	One per eight LOTs	One per eight LOTs

**160-3.2.1.1 Verification Comparison Criteria and Resolution**

**Procedures:** If the QC and the Department’s Verification tests meet the requirements of Section 914 then the Engineer will accept the corresponding LOTs. Otherwise, the Engineer will submit the Resolution sample to the State Materials Office (SMO) or an AASHTO accredited laboratory designated by SMO to perform Resolution testing.

If the Resolution Test results meet the requirements of Section 914 then the Engineer will accept the LOTs in question. Otherwise remove the material and apply new material meeting the requirements of Section 914 and retest in accordance with 160-3.2.

**160-3.3 Mixing:** Perform mixing using rotary tillers, a plant or other equipment meeting the approval of the Engineer. The subgrade may be mixed in one course if the equipment and method of construction provides the uniformity, particle size limitation, compaction and other desired results of 160-4. Thoroughly mix the area to be stabilized throughout the entire depth and width of the stabilizing limits.

Perform the mixing operations, as specified, (either in place or in a plant) regardless of whether the existing soil, or any select soils placed within the limits of the stabilized sections, have the required bearing value without the addition of stabilizing materials.

**160-3.4 Maximum Particle Size of Mixed Materials:** At the completion of the mixing, ensure that the gradation of the material within the limits of the area being stabilized is such that 97% will pass a 3 1/2 inch sieve and that the material does not have a plasticity index greater than eight or liquid limit greater than 30. Remove any materials not meeting the plasticity requirements from the stabilized area. Break down or remove from the stabilized area materials, including clay lumps or lumps made of clay-size particles (any particle size 2 microns or less), not meeting the gradation requirements.

**160-3.5 Bearing Value:** Meet the bearing value requirements for the subgrade in accordance with 160-4.

**160-3.6 Compaction:** After completing the mixing operations and satisfying the requirements for bearing value, uniformity, and particle size. Compact the materials at a moisture content permitting the specified compaction in 160-4.2.3. If the moisture content of the material is improper for attaining the specified density, either add water or allow the material to dry until reaching the proper moisture content for the specified compaction.

**160-3.7 Finish Grading:** Shape the completed stabilized subgrade to conform with the finished lines, grades, and cross-section indicated in the Plans. Check the subgrade using elevation stakes or other means approved by the Engineer.

**160-3.8 Requirements for Condition of Completed Subgrade:** After completing the stabilizing and compacting operations, ensure that the subgrade is firm and substantially unyielding to the extent that it will support construction equipment and will have the bearing value required by the Plans.

Remove all soft and yielding material, and any other portions of the subgrade which will not compact readily, and replace it with suitable material so that the whole subgrade is brought to line and grade, with proper allowance for subsequent compaction.

**160-3.9 Maintenance of Completed Subgrade:** After completing the subgrade as specified above, maintain it free from ruts, depressions, and any damage resulting from the hauling or handling of materials, equipment, tools, etc. The Contractor is responsible for maintaining the required density until the subsequent base or pavement is in place including any repairs, replacement, etc., of curb and gutter, sidewalk, etc., which might become necessary in order to recompact the subgrade in the event of underwash or other damage occurring to the previously compacted subgrade. Perform any such recompaction at no expense to the Department. Construct and maintain ditches and drains along the completed subgrade section.

**160-4 Acceptance Program.**

**160-4.1 General Requirements:** Meet the requirements of 120-10, except use 160-4.2 instead of 120-10.2, 160-4.3 instead of 120-10.3, and 160-4.4 instead of 120-10.4.

**160-4.2 Acceptance Criteria:**

**160-4.2.1 Bearing Value Requirements:**

**160-4.2.1.1 General:** Within the entire limits of the width and depth of the areas to be stabilized, obtain the required minimum bearing value for each LOT. For any area where the bearing value obtained is deficient from the value indicated in the Plans, in excess of the tolerances established herein, spread and mix additional stabilizing material in accordance with 160-3.3. Perform this reprocessing for the full width of the roadway being stabilized and longitudinally for a distance of 50 feet beyond the limits of the area in which the bearing value is deficient.

Determine the quantity of additional stabilizing material to be used in reprocessing.

**160-4.2.1.2 Under-tolerances in Bearing Value Requirements:** The under-tolerances are allowed for the following specified Bearing Values:

Specified Bearing Value	Under-tolerance
LBR 40	5.0
LBR 35	4.0
LBR 30 (and under)	2.5

The following unsoaked bearing value requirement is based on tests performed on samples obtained after completing mixing operations:

Specified Bearing Value	Unsoaked Bearing Value Required	Under-tolerance
LBR 40	LBR 43	0.0

**160-4.2.2 Mixing Depth Requirements:** Do not exceed individual plan depth thickness by more than 2 inches or exceed LOT-average depth thickness by more than 1 inch measured to the nearest 0.25 inch. No undertolerance of mixing depth is allowed.

As an exception to the above mixing requirements, where the subgrade is of rock, the Engineer may waive the mixing operations (and the work of stabilizing), and the Department will not pay for stabilization for such sections of the roadway.

**160-4.2.3 Density Requirements:**

**160-4.2.3.1 General:** Within the entire limits of the width and depth of the areas to be stabilized, other than as provided in 160-4.2.3.2, obtain a minimum density at any location of 98% of the Modified Proctor maximum density as determined by FM 1-T 180, Method D.

**160-4.2.3.2 Exceptions to Density Requirements:** The Contractor need not obtain the minimum density specified in 160-4.2.3.1 if within the following limits:

(a) The width and depth of areas which are to be subsequently incorporated into a base course under the same contract.

(b) The upper 6 inches of areas to be grassed under the same contract. Compact these areas to a reasonably firm condition as directed by the Engineer.

**160-4.2.4 Frequency:** Conduct QC sampling and testing at a minimum frequency listed in the table below. The Engineer will perform Verification sampling and tests at a minimum frequency listed in the table below.

Test Name	Quality Control	Verification	Verification for Shoulder-Only, Shared Use Path and Sidewalk Construction
Modified Proctor Maximum Density	One per two consecutive LOTs	One per eight consecutive LOTs	One per four LOTs
Density	One per LOT	One per four LOTs	One per two LOTs
Stabilizing Mixing Depth	Three per 500 feet	Witness one per LOT	Witness one per LOT
LBR	One per two consecutive LOTs	One per eight consecutive LOTs	One per four LOTs
Gradation, LL/PI & Soil Classification (Local materials)	Not Required	One per eight consecutive LOTs	One per four LOTs

**160-4.3 Additional Requirements:**

**160-4.3.1 Quality Control Testing:**

**160-4.3.1.1 Bearing Values:** Test the stabilized subgrade sample collected in 160-4.3.1.3. Determine the LBR in accordance with FM 5-515 and 160-4.2.4.

**160-4.3.1.1.1 Unsoaked LBR:** If unsoaked LBR is desired, submit request for approval to the Engineer. Upon approval by the Engineer to consider the use of unsoaked LBR, randomly sample and test from three locations in the initial Lot for both soaked and unsoaked LBR in accordance with FM 5-515. Ensure all of the tests demonstrate the material achieves the LBR values in 160-4.2.1.2. Continue testing unsoaked LBR at the frequency shown

in 160-4.2.4. Discontinue unsoaked LBR testing if any unsatisfactory QC LBR test result is obtained or resolution determines an unsatisfactory LBR.

**160-4.3.1.2 Mixing Depths:** Meet required plan mixing-depths by measuring from the proposed final grade line. Determine test locations, including stations and offsets, using the Random Number generator approved by the Department. Notify the Engineer a minimum of 24 hours before checking mixing depths. Record results on forms supplied by the Department.

**160-4.3.1.3 Modified Proctor Maximum Density Requirement:** Collect enough material to split and create three separate samples. Determine test locations, including stations and offsets, using the Random Number generator approved by the Department for the two LOTs under consideration. Retain the Verification and Resolution samples for the Department until the Engineer accepts the LOTs represented by the samples.

**160-4.3.2 Department Verification Tests:**

**160-4.3.2.1 Bearing Value & Soil Classification:** The Engineer will collect a sample at a location other than the location where the sample was collected in 160-4.3.1.3, and test the stabilized subgrade for determination of the LBR in accordance with FM 5-515. The Engineer will select test locations, including stations and offsets, using a Random Number generator, based on the LOTs under consideration.

If local material is used for stabilizing, the Engineer will determine compliance with embankment utilization requirements and 160-3.4 by testing and classifying the stabilized subgrade in accordance with AASHTO T88 and AASHTO M 145 at the frequency shown in 160-4.2.4.

**160-4.3.2.1.1 Unsoaked LBR:** The Engineer will sample and test the initial LOT for one soaked and one unsoaked LBR if consideration of the unsoaked LBR has been approved.

**160-4.3.2.2 Mixing Depth:** The Engineer will witness the Contractor's mixing depth checks to ensure compliance with 160-4.2.2. The Engineer will select test locations, including stations and offsets, using a Random Number generator.

**160-4.3.2.3 Modified Proctor Maximum Density:** The Engineer will randomly select one of the retained split samples and test in accordance with FM 1-T 180, Method D.

**160-4.4 Verification Comparison Criteria and Resolution Procedures:**

**160-4.4.1 Bearing Value & Soil Classification:** If the Department's Verification test meets the requirements of 160-4.2.1 and embankment utilization requirements, the Engineer will accept the corresponding LOTs. Otherwise, the Engineer will collect an additional sample in the same LOT the Verification sample was obtained. SMO or an AASHTO accredited laboratory designated by SMO will perform Resolution testing on the additional sample. The material will be sampled and tested in accordance with FM 5-515. If local material is used for stabilization, the sample will be tested in accordance with AASHTO T-88, and AASHTO M-145.

If the Resolution Testing results meet the requirements of 160-4.2.1 and embankment utilization requirements then the Engineer will accept the LOTs in question. Otherwise reprocess the corresponding LOTs in accordance with 160-3 and retest in accordance with 160-4.3.1.1.

**160-4.4.2 Mixing Depth Thickness:** The Department will witness the mixing depth checks.

1. If the depth checks meet the requirements of 160-4.2.2 the Engineer will accept that 500-foot section.
2. If the depth checks confirm shallow depth, re-mix the 500-foot section to an appropriate depth and re-measure in accordance with 160-4.3.1.2. The Engineer will repeat the witness process.
3. If the depth checks confirm extra deep mixing, conduct an additional QC density test after compaction for the bottom 12 inches of the subgrade for that 500-foot section in addition to a QC density test for the top 12 inches. The additional density test must meet the requirements of 160-4.2.3.

**160-4.4.3 Modified Proctor Maximum Density Determination:** The Engineer will compare the Verification test results of 160-4.3.2.3 to the corresponding Quality Control test results. If the test result is within 4.5 lb/ft<sup>3</sup> of the QC test result, the LOTs will be verified. Otherwise, the Engineer will collect the Resolution split sample corresponding to the Verification sample tested. SMO or an AASHTO accredited laboratory designated by SMO will perform Resolution testing. The material will be sampled and tested in accordance with FM 1-T 180, Method D.

The Engineer will compare the Resolution Test results with the QC test results. If the Resolution Test result is within 4.5 lb/ft<sup>3</sup> of the corresponding QC test result, the Engineer will use the QC test results for material acceptance purposes for each corresponding pair of LOTs. If the Resolution test result is not within 4.5 lb/ft<sup>3</sup> of the corresponding QC test, the Engineer will collect the remaining Verification split samples for testing. Verification Test results will be used for material acceptance purposes for the LOTs in question.

**160-4.4.4 Density:** When a Verification or Independent Verification density test does not meet 160-4.2.3 (Acceptance Criteria), retest at a site within a 5 feet radius of the Verification test location and observe the following:

1. If the QC retest meets the Acceptance Criteria and compares favorably with the Verification or Independent Verification test, the Engineer will accept the LOTs in question.
2. If the QC retest does not meet the Acceptance Criteria and compares favorably with the Verification or Independent Verification test, rework and retest the material in that LOT. The Engineer will re-verify the LOTs in question.
3. If the QC retest and the Verification or Independent Verification test do not compare favorably, complete a new equipment-comparison analysis as defined in 120-10.1.2. Once acceptable comparison is achieved, retest the LOTs. The Engineer will perform new verification testing. Acceptance testing will not begin on a new LOT until the Contractor has a gauge that meets the comparison requirements.

### **160-5 Method of Measurement.**

The quantity to be paid for will be the plan quantity, in square yards, completed and accepted.

### **160-6 Basis of Payment.**

Price and payment will constitute full compensation for all work and materials specified in this Section, including furnishing, spreading and mixing of all stabilizing material required and any reprocessing of stabilization areas necessary to attain the specified bearing value. The Department will make full payment for any areas where the existing subgrade materials meet the design bearing value requirements without the addition of stabilizing additives, as well as areas



where the Contractor may elect to place select high-bearing materials from other sources within the limits of the stabilizing.

If the item of borrow excavation is included in the Contract, any stabilizing materials obtained from designated borrow areas will be included in the pay quantity for borrow excavation.

Payment will be made under:

Item No. 160- 4- Stabilization - per square yard.

## BASE COURSES

### SECTION 200 ROCK BASE

#### **200-1 Description.**

Construct a base composed of base rock. Perform work in accordance with an approved Quality Control Plan meeting the requirements of 105-3.

#### **200-2 Materials.**

**200-2.1 General:** Meet the requirements of either Section 911, 913, 913A or 915 for the particular type of base to be constructed. The Contractor may use more than one source of base rock on a single Contract provided that a single source is used throughout the entire width and depth of a section of base. Obtain approval from the Engineer before placing material from more than one source. Place material to ensure total thickness single source integrity at any station location of the base. Intermittent placement or “blending” of sources is not permitted. Base rock may be referred to hereinafter as “rock”.

The reuse of existing base may be considered provided it meets the requirements of this Section. Submit as a Cost Savings Initiative Proposal in accordance with Section 4.

**200-2.2 Existing Rock:** Meet the following requirements for use of existing rock on the same project:

1. Notify the Engineer in writing prior to excavating existing rock.
2. Submit a process control plan, herein referred to as “Plan” consisting of the following:
  - a. Locations where existing rock will be removed from the roadway.
  - b. Locations where existing rock will be used for new construction.
  - c. Method of excavation, transport, and placement to ensure excavated rock will be kept separate from other approved stockpiles. Excavation methods that may result in damage to the rock rendering it unfit to be used as base will not be approved.
  - d. Proposed measures to prevent contamination and segregation.
  - e. Proposed locations and methods for constructing stockpiles for sampling and testing.
  - f. Method for sampling and reporting test results.
3. The Engineer will coordinate the review of the “Plan” with the District Materials Office.
4. Upon the Engineer’s review of the “Plan”, build a preliminary stockpile, not to exceed 1,000 cubic yards.
5. Collect and test a minimum of three samples from the preliminary stockpile. Once the stockpile has been sampled, do not add any additional material to the stockpile. Determine compliance with 200-2.1, with the exception of carbonate contents. Reject any stockpile if the Limerock Bearing Ratio (LBR) is less than 100. The District Materials Office will sample and test the preliminary stockpile to verify compliance with this Section.
6. If all test results meet the requirements of this Section, the Engineer will notify the Contractor in writing of the approved status of the preliminary stockpile based on the analysis of test data performed by the District Materials Office.

7. If the use of existing rock is approved, continue to produce additional stockpiles not exceeding 1,000 cubic yards. Ensure the rock meets the requirements of this Section by sampling and testing each new stockpile at a minimum frequency of one sample per 400 cubic yards. Once a stockpile has been sampled, do not add additional material to that stockpile. The District Materials Office may also perform sampling and testing. Materials will be accepted if test results meet the requirements of this Section.

8. After 10 consecutive quality control LBR test results meet the requirements of the Section and no individual LBR test is less than 120, the sampling and testing frequency may be reduced to a minimum frequency of one sample per 800 cubic yards for each stockpile. Notify the Engineer in writing prior to reducing testing frequency. If any quality control LBR test result falls below 120 or a stockpile is rejected, revert to original sampling frequency of one sample per 400 cubic yards.

9. Construct a new preliminary stockpile if there is a change in material, conditions not addressed in the “Plan” are encountered, or if production varies from the approved “Plan”.

### **200-3 Equipment.**

Use mechanical rock spreaders, equipped with a device that strikes off the rock uniformly to laying thickness, capable of producing even distribution. For crossovers, intersections and ramp areas; roadway widths of 20 feet or less; the main roadway area when forms are used and any other areas where the use of a mechanical spreader is not practicable; the Contractor may spread the rock using bulldozers or blade graders.

### **200-4 Transporting Rock.**

Transport the rock to its point of use, over rock previously placed, if practicable, and dump it on the end of the preceding spread. Hauling and dumping on the subgrade will be permitted only when, in the Engineer’s opinion, these operations will not be detrimental to the subgrade.

### **200-5 Spreading Rock.**

**200-5.1 Method of Spreading:** Spread the rock uniformly. Remove all segregated areas of fine or coarse rock and replace them with properly graded rock.

**200-5.2 Number of Courses:** When the specified compacted thickness of the base is greater than 6 inches, construct the base in multiple courses of equal thickness. Individual courses shall not be less than 3 inches. The thickness of the first course may be increased to bear the weight of the construction equipment without disturbing the subgrade.

If, through field tests, the Contractor can demonstrate that the compaction equipment can achieve density for the full depth of a thicker lift, and if approved by the Engineer, the base may be constructed in successive courses of not more than 8 inches compacted thickness.

The Engineer will base approval on results of a test section constructed using the Contractor’s specified compaction effort. Notify the Engineer prior to beginning construction of a test section. Construct a test section of the length of one LOT. Perform five QC density tests at random locations within the test section. At each test site, test the bottom 6 inches in addition to the entire course thickness. All QC tests and a Department Verification test must meet the density required by 200-7.2.1. Identify the test section with the compaction effort and thickness in the Logbook. Remove the materials above the bottom 6 inches, at no expense to the

Department. The minimum density required on the thicker lift will be the average of the five results obtained on the thick lift in the passing test section. Maintain the exposed surface as close to “undisturbed” as possible; no further compaction will be permitted during the test preparation. If unable to achieve the required density, remove and replace or repair the test section to comply with the specifications at no additional expense to the Department. The Contractor may elect to place material in 6 inches compacted thickness at any time.

Once approved, a change in the source of base material will require the construction of a new test section. Do not change the compaction effort once the test section is approved. The Engineer will periodically verify the density of the bottom 6 inches during thick lift operations.

The Engineer may terminate the use of thick lift construction and instruct the Contractor to revert to the 6 inches maximum lift thickness if the Contractor fails to achieve satisfactory results or meet applicable specifications.

**200-5.3 Rock Base for Shoulder Pavement:** Unless otherwise permitted, complete all rock base shoulder construction at any particular location before placing the final course of pavement on the traveled roadway. When dumping material for the construction of a rock base on the shoulders, do not allow material capable of scarring or contaminating the pavement surface on the adjacent pavement. Immediately sweep off any rock material that is deposited on the surface course.

## **200-6 Compacting and Finishing Base.**

**200-6.1 General:** Construct mainline pavement lanes, turn lanes, ramps, parking lots, concrete box culverts and retaining wall systems meeting the requirements of 120-8.1, except replace “embankment” with “base”.

Construct shoulder-only areas, shared use paths, and sidewalks. Meet the requirements of 120-8.1 except replace “embankment” with “base” meeting the acceptance criteria of 200-7.2. Shoulders compacted separately shall be considered separate LOTs.

**200-6.1.1 Single Course Base:** After spreading, scarify the entire surface, then shape the base to produce the required grade and cross-section, free of scabs and laminations, after compaction.

**200-6.1.2 Multiple Course Base:** Clean the first course of foreign material, then blade and bring it to a surface cross-section approximately parallel to the finished base. Before spreading any material for the upper courses, allow the Engineer to make density tests for the lower courses to determine that the required compaction has been obtained. After spreading the material for the top course, scarify finish and shape its surface to produce the required grade and cross-section, free of scabs and laminations, after compaction.

**200-6.2 Moisture Content:** When the material does not have the proper moisture content to ensure the required density, wet or dry it as required. When adding water, uniformly mix it in to the full depth of the course that is being compacted. During wetting or drying operations, manipulate, as a unit, the entire width and depth of the course that is being compacted.

**200-6.3 Thickness Requirements:** Within the entire limits of the length and width of the finished base, meet the specified plan thickness in accordance with the requirements of 200-7.3.1.2.

## **200-6.4 Correction of Defects:**

**200-6.4.1 Contamination of Base Material:** If, at any time, the subgrade material becomes mixed with the base course material, dig out and remove the mixture, and reshape and compact the subgrade. Then replace the materials removed with clean base material, and shape and compact as specified above. Perform this work at no expense to the Department.

**200-6.4.2 Cracks and Checks:** If cracks or checks appear in the base, either before or after priming, which, in the opinion of the Engineer, would impair the structural efficiency of the base, remove the cracks or checks by rescarifying, reshaping, adding base material where necessary, and recompacting.

**200-6.5 Compaction of Widening Strips:** Where base construction consists of widening strips and the trench width is not sufficient to permit use of standard base compaction equipment, compact the base using vibratory compactors, trench rollers or other special equipment which will achieve the density requirements specified herein.

When multiple course base construction is required, compact each course prior to spreading material for the overlaying course.

**200-7 Acceptance Program.**

**200-7.1 General Requirements:** Meet the requirements of 120-10, except use 200-7.2 instead of 120-10.2, 200-7.3 instead of 120-10.3 and 200-7.4 instead of 120-10.4.

**200-7.2 Acceptance Criteria:**

**200-7.2.1 Density:** Within the entire limits of the width and depth of the base, obtain a minimum density in any LOT of 98% of modified Proctor maximum density as determined by FM 1-T 180, Method D or the Pit Proctor when using the Pit Proctor option. For shoulder only areas and bike/shared use paths, obtain a minimum density of 95% of the modified Proctor maximum density as determined by FM 1-T 180, Method D or the Pit Proctor when using the Pit Proctor option.

**200-7.2.2 Frequency:** Conduct QC sampling and testing at a minimum frequency listed in the table below. The Engineer will perform Verification sampling and tests at a minimum frequency listed in the table below.

Mainline Pavement Lanes, Turn Lanes, Ramps, Parking Lots, Concrete Box Culverts and Retaining Wall Systems		
Test Name	Quality Control	Verification
Modified Proctor Maximum Density	One per eight consecutive LOTs	One per 16 consecutive LOTs
Density	One per LOT	One per four LOTs
Roadway Surface	Ten per LOT	Witness
Roadway Thickness	Three per LOT	Witness

Shoulder-Only, Shared Use Path and Sidewalk Construction		
Test Name	Quality Control	Verification
Modified Proctor Maximum Density	One per two LOTs	One per four LOTs
Density	One per LOT	One per two LOTs
Surface	Five per 500 feet	Witness
Thickness	Three per 1000 consecutive feet	Witness

**200-7.2.3 Pit Proctor:** In lieu of Modified Proctor Maximum Density testing at the roadway, notify the Engineer in writing of a Contractor option to use the Pit Proctor supplied by the Department. The Modified Proctor maximum density frequency requirements of 200-7.2.2

shall not apply. The Department will determine the Pit Proctor from statistical analysis of the base rock Modified Proctor maximum density at Department approved mines. For posting of Mines and Pit Proctors for each calendar quarter refer to the State Materials Office internet website at <http://www.dot.state.fl.us/statematerialsoffice/>. Use the current posted Pit Proctor value in lieu of the Modified Proctor maximum density required by 200-7.2.1. Use the current posted Pit Proctor value for density acceptance during the quarter corresponding to the posting. Notify the Engineer in writing if returning to the provisions of 200-7.2 and 200-7.2.2 but do not re-elect to use the Pit Proctor until the start of the next calendar quarter.

**200-7.3 Additional Requirements:**

**200-7.3.1 Quality Control Testing:**

**200-7.3.1.1 Modified Proctor Maximum Density Requirement:** Collect enough material to split and create three separate samples and retain two for the Engineer's Verification and Resolution testing until the Engineer accepts the 16 LOTs represented by the samples.

**200-7.3.1.2 Depth and Surface Testing Requirements:** Notify the Engineer a minimum of 24 hours before checking base depths and surface checking. Determine test locations including Stations and Offsets, using the Random Number generator approved by the Department. Do not perform depth and surface checks until the Engineer is present to witness. Enter test results into the Department's database. Perform thickness check on the finished base or granular subbase component of a composite base. Provide traffic control, coring/boring equipment, and an operator for the coring/boring equipment. Traffic control is to be provided in accordance with the standard maintenance of traffic requirements of the Contract.

The thickness is considered deficient, if the measured depth is over 1/2 inch less than the specified thickness. Correct all deficient areas of the completed base by scarifying and adding additional base material. As an exception, if authorized by the Department, such areas may be left in place without correction and with no payment.

Check the finished surface of the base course with a template cut to the required crown and with a 15 foot straightedge laid parallel to the centerline of the road. Correct all irregularities greater than 1/4 inch to the satisfaction of the Engineer by scarifying and removing or adding rock as required, and recompact the entire area as specified hereinbefore.

**200-7.3.1.3 Surface & Thickness Reduced Testing Frequency:** When no Resolution testing is required for 12 consecutive verified LOTs, or if required, the QC test data was upheld, reduce the QC surface and/or thickness checks to one half the minimum requirements as stated in 200-7.2.2 (eg. Reduce frequency from ten per LOT to ten per two LOTs) by identifying the substantiating tests and notifying the Engineer in writing prior to starting reduced frequency of testing. If the Verification test fails, and Quality Control test data is not upheld by Resolution testing the Quality Control testing will revert to the original frequency of 200-7.2.2. The results of the Independent Verification testing will not affect the frequency of the Quality Control testing.

**200-7.3.2 Department Verification Tests:**

**200-7.3.2.1 Maximum Density:** The Engineer will randomly select one of the remaining two split samples and test in accordance with FM 1-T 180, Method D.

**200-7.3.2.2 Thickness and Surface Testing Requirements:** The Department will witness the base depth and surface checks to ensure compliance with 200-7.3.1.2. If the QC test results are not deficient as defined in 200-7.3.1.2, the LOT or 500-foot

section will be accepted. If the QC test results are deficient, resolve deficiencies in accordance with 200-7.3.1.2. Repeat acceptance testing. Provide traffic control, coring/boring equipment, and an operator for the coring/boring equipment.

**200-7.4 Verification Comparison Criteria and Resolution Procedures:**

**200-7.4.1 Modified Proctor Maximum Density:** The Engineer will compare the Verification test results of 200-7.3.2.1 to the corresponding Quality Control test results. If the test result is within  $4.5 \text{ lb/ft}^3$  of the QC test result, the LOTs will be verified. Otherwise, the Engineer will collect the Resolution split sample corresponding to the Verification sample tested. The State Materials Office or an AASHTO accredited laboratory designated by the State Materials Office will perform Resolution testing. The material will be sampled and tested in accordance with FM 1-T 180, Method D.

The Engineer will compare the Resolution Test results with the Quality Control test results. If the Resolution Test result is within  $4.5 \text{ lb/ft}^3$  of the corresponding Quality Control test result, the Engineer will use the Quality Control test results for material acceptance purposes for each corresponding set of LOTs. If the Resolution test result is not within  $4.5 \text{ lb/ft}^3$  of the corresponding Quality Control test, the Engineer will collect the remaining Verification split sample for testing. Verification Test results will be used for material acceptance purposes for the LOTs in question.

**200-7.4.2 Pit Proctor:** When using the Pit Proctor option, the Engineer will, at a minimum frequency of one per 16 LOTS, select a random location to collect an Independent Verification (IV) sample and test material to obtain a Modified Proctor maximum density as determined by FM 1-T 180, Method D. The Engineer will collect enough material to split and hold a sample for Resolution testing. The Engineer will compare the IV results with the Pit Proctor. If the IV result is lower than or equal to the Pit Proctor plus 4.5 pcf, keep the option to use the Pit Proctor. If the IV result is more than 4.5 pcf higher than the Pit Proctor the Engineer will test the Resolution sample and compare the Resolution result with the Pit Proctor. If the Resolution result is higher than but within 4.5 pcf of the Pit Proctor, keep the option to use the Pit Proctor. Otherwise return to the provisions of 200-7.2.2, 200-7.3.1.1, 200-7.3.2.1, and 200-7.4.1.

**200-7.4.3 Density:** When a Verification or Independent Verification density test does not meet the requirements of 200-7.2.1 (Acceptance Criteria), retest at a site within a 5 feet radius of the Verification test location and observe the following:

1. If the Quality Control retest meets the Acceptance Criteria and compares favorably with the Verification or Independent Verification test, the Engineer will accept the LOTs in question.

2. If the Quality Control retest does not meet the Acceptance Criteria and compares favorably with the Verification or Independent Verification test, rework and retest the material in that LOT. The Engineer will re-verify the LOTs in question.

3. If the Quality Control retest and the Verification or Independent Verification test do not compare favorably, complete a new equipment-comparison analysis as defined in 120-10.1.1. Once acceptable comparison is achieved, retest the LOTs. The Engineer will perform new verification testing. Acceptance testing will not begin on a new LOT until the Contractor has a gauge that meets the comparison requirements.

**200-7.4.4 Thickness and Surface Testing Requirements:** Resolve deficiencies in accordance with 200-7.3.1.2.

## **200-8 Priming and Maintaining.**

**200-8.1 Priming:** Apply the prime coat only when the base meets the specified density requirements and when the moisture content in the top half of the base does not exceed the optimum moisture of the base material. At the time of priming, ensure that the base is firm, unyielding and in such condition that no undue distortion will occur.

**200-8.2 Maintaining:** Maintain the true crown and template, with no rutting or other distortion, while applying the surface course.

## **200-9 Calculations for Average Thickness of Base.**

For bases that are not mixed in place, the Engineer will determine the average thickness from the measurements specified in 200-10.1, calculated as follows:

(a) When the measured thickness is more than 1/2 inch greater than the design thickness shown on the typical cross-section in the Plans, it will be considered as the design thickness plus 1/2 inch.

(b) Average thickness will be calculated per typical cross-section for the entire job as a unit.

(c) Any areas of base left in place with no payment will not be included in the calculations.

(d) Where it is not possible through borings to distinguish the base materials from the underlying materials, the thickness of the base used in the measurement will be the design thickness.

## **200-10 Method of Measurement.**

**200-10.1 General:** The quantity to be paid for will be the plan quantity, adjusted as specified below.

**200-10.2 Authorized Normal Thickness Base:** The surface area of authorized normal thickness base to be adjusted will be the plan quantity as specified above, omitting any areas not allowed for payment under the provisions of 200-6.3 and omitting areas which are to be included for payment under 200-10.3. The adjustment shall be made by adding or deducting, as appropriate, the area of base represented by the difference between the calculated average thickness, determined as provided in 200-9, and the specified normal thickness, converted to equivalent square yards of normal thickness base.

**200-10.3 Authorized Variable Thickness Base:** Where the base is constructed to a compacted thickness other than the normal thickness as shown on the typical section in the Plans, as specified in the Plans or ordered by the Engineer for providing additional depths at culverts or bridges, or for providing transitions to connecting pavements, the volume of such authorized variable thickness compacted base will be calculated from authorized lines and grades, or by other methods selected by the Engineer, converted to equivalent square yards of normal thickness base for payment.

## **200-11 Basis of Payment.**

Price and payment will be full compensation for all the work specified in this Section, including correcting all defective surface and deficient thickness, removing cracks and checks as provided in 200-6.4.2, the prime coat application as directed in 300-8, and the additional rock required for crack elimination.

Payment shall be made under:

Item No. 285- 7- Optional Base - per square yard.



**SECTION 204  
GRADED AGGREGATE BASE**

**204-1 Description.**

Construct a base course composed of graded aggregate.

**204-2 Materials.**

Use graded aggregate material, produced from Department approved sources, which yields a satisfactory mixture meeting all the requirements of these Specifications after it has been crushed and processed as a part of the mining operations.

The Contractor may furnish the material in two sizes of such gradation that, when combined in a central mix plant pugmill, the resultant mixture meets the required specifications.

Use graded aggregate base material of uniform quality throughout, substantially free from vegetable matter, shale, lumps and clay balls, and having a Limerock Bearing Ratio value of not less than 100. Use material retained on the No. 10 sieve composed of aggregate meeting the following requirements:

Soundness Loss, Sodium, Sulfate: AASHTO T104 ..... 15%  
Percent Wear: AASHTO T96 (Grading A)

Group 1 Aggregates ..... 45%  
Group 2 Aggregates ..... 65%

Group 1: This group of aggregates is composed of limestone, marble, or dolomite.

Group 2: This group of aggregates is composed of granite, gneiss, or quartzite.

Use graded aggregate base material meeting the following gradation:

Sieve Size	Percent by Weight Passing
2 inch	100
1 1/2 inch	95 to 100
3/4 inch	65 to 90
3/8 inch	45 to 75
No. 4	35 to 60
No. 10	25 to 45
No. 50	5 to 25
No. 200	0 to 10

For Group 1 aggregates, ensure that the fraction passing the No. 40 sieve has a Plasticity Index (AASHTO T90) of not more than 4.0 and a Liquid Limit (AASHTO T89) of not more than 25, and contains not more than 67% of the weight passing the No. 200 sieve.

For Group 2 aggregates, ensure that the material passing the No. 10 sieve has a sand equivalent (AASHTO T176) value of not less than 28.

The Contractor may use graded aggregate of either Group 1 or Group 2, but only use one group on any Contract. (Graded aggregate may be referred to hereinafter as “aggregate”.)

**204-3 Equipment.**

Provide equipment meeting the requirements of 200-3.

**204-4 Transporting Aggregate.**

Transport aggregate as specified in 200-4.

**204-5 Spreading Aggregate.**

Spread aggregate as specified in 200-5.

**204-6 Compacting and Finishing Base.**

**204-6.1 General:** Meet the requirements of 200-7.1 with density requirements of 204-6.3.

**204-6.1.1 Single-Course Base:** Construct as specified in 200-6.1.1.

**204-6.1.2 Multiple-Course Base:** Construct as specified in 200-6.1.2.

**204-6.2 Moisture Content:** Meet the requirements of 200-6.2.

**204-6.3 Density Requirements:** After attaining the proper moisture conditions, uniformly compact the material to a density of not less than 100% of the maximum density as determined by FM 1-T 180. Ensure that the minimum density that will be acceptable at any location outside the traveled roadway (such as intersections, crossovers, turnouts, etc.) is 98% of the maximum density.

**204-6.4 Density Tests:** Meet the requirements of 200-7.2.

**204-6.5 Correction of Defects:** Meet the requirements of 200-6.4.

**204-6.6 Dust Abatement:** Minimize the dispersion of dust from the base material during construction and maintenance operations by applying water or other dust control materials.

**204-7 Testing Surface.**

Test the surface in accordance with the requirements of 200-7.

**204-8 Priming and Maintaining.**

Meet the requirements of 200-8.

**204-9 Thickness Requirements.**

Meet the requirements of 285-6.

**204-10 Calculations for Average Thickness of Base.**

Calculations for determining the average thickness of base will be made in accordance with 285-7.

**204-11 Method of Measurement.**

**204-11.1 General:** The quantity to be paid for will be the area, in square yards, completed and accepted.

**204-11.2 Authorized Normal Thickness Base:** The surface area of authorized normal thickness base will be calculated as specified in 9-1.3, omitting any areas not allowed for payment under the provisions of 204-9 and omitting areas which are to be included for payment under 204-11.3. The area for payment, of authorized normal thickness base, will be the surface area determined as provided above, adjusted by adding or deducting, as appropriate, the area of base represented by the difference between the calculated average thickness, determined as provided in 204-10, and the specified normal thickness, converted to equivalent square yards of normal thickness base.

**204-11.3 Authorized Variable Thickness Base:** As specified in 200-10.3.

**SECTION 331**  
**TYPE S ASPHALT CONCRETE, QUALITY**  
**ASSURANCE AND ACCEPTANCE PROCEDURES**

**331-1 Description.**

**331-1.1 General:** Construct a Type S Asphalt Concrete course (using the Quality Assurance acceptance system) using the type of mixture specified in the Contract, or when offered as alternates, as selected. If offered as alternates, meet the layer thickness criteria specified in 331-1.2. Type S mixes are identified as Type S-I, Type S-II, or Type S-III. The composition and physical test properties for all mixes including Type S Asphalt Concrete are shown in Tables 331-1 and 331-2. This Section establishes Acceptance Procedures for materials and work performed under Sections 280, 290, 331, 332, 333, 335, and 337.

Where Type S Asphalt Concrete is specified in the Contract, if approved by the Engineer, the equivalent fine Type SP Asphalt Concrete mixture (Traffic Level C) meeting the requirements of Section 334 may be selected as an alternate at no additional cost to the Department. The equivalent mixes are as follows:

Type S-I ..... Type SP-12.5  
 Type S-II ..... Type SP-19.0  
 Type S-III ..... Type SP-9.5

Meet the requirements for plant and equipment specified in Section 320. Meet the general construction requirements specified in Section 330.

Table 331-1 Bituminous Concrete Mixtures (Gradation Design Range)								
Type	Total Aggregate Passing Sieves <sup>1</sup>							
	3/4 inch [19.0 mm]	1/2 inch [12.5 mm]	3/8 inch [9.5 mm]	No. 4 [4.75 mm]	No. 10 [2.0 mm]	No. 40 [425 μm]	No. 80 [180 μm]	No. 200 [75 μm]
S-I <sup>5</sup>	100	88-98	75-93	47-75	31-53	19-35	7-21	2-6
S-II <sup>2</sup>	83-98	71-87	62-78	47-63	33-49	19-35	9-18	2-6
S-III <sup>5</sup>		100	88-98	60-90	40-70	20-45	10-30	2-6
Type II		100	90-100	80-100	55-90			2-12
Type III		100	80-100	65-100	40-75	20-45	10-30	2-10
SAHM		100						0-12
ABC-1		100						0-12
ABC-2		100			55-90			0-12
ABC-3 <sup>3</sup>	70-100			30-70	20-60	10-40		2-10
FC-2 <sup>4</sup>		100	85-100	10-40	4-12			2-5
FC-3 <sup>5</sup>		100	88-98	60-90	40-70	20-45	10-30	2-6

<sup>1</sup> In inches [mm] or sieves [μm].  
<sup>2</sup> 100% passing 1 1/4 inch [31.5 mm] sieve and 94 to 100% passing 1 inch [25.0 mm] sieve.  
<sup>3</sup> 100% passing 1 1/2 inch [37.5 mm] sieve.  
<sup>4</sup> The Engineer may increase the design range for the No. 10 [2.00 mm] sieve for lightweight aggregates.  
<sup>5</sup> The Engineer may retain up to 1% on the maximum sieve size.

Table 331-2 Non SI Units Marshall Design Properties For Bituminous Concrete Mixes
--

Mix Type	Minimum Marshall Stability (lbs.)	Flow** (0.01 in.)	Minimum VMA (%)	Air Voids (%)	Minimum Effective Asphalt Content (%)	VFA Voids Filled with Asphalt (%)
S-I	1,500*	8-13	14.5	4-5	***	65-75
S-II	1,500*	8-13	13.5	4-5	***	65-75
S-III	1,500*	8-13	15.5	4-6	***	65-75
Type II	500-750	7-15	18	5-16	6.0	-
Type III	750-1,000	7-15	15	5-12	5.5	-
SAHM	300-500	7-15	15	5-16	6.0	-
ABC-1	500	7-15	15	5-16	6.0	-
ABC-2	750	7-15	15	5-14	5.5	-
ABC-3	1,000	8-13	14	4-7	***	65-78
FC-2	-	-	-	-	-	-
FC-3	1,500	8-13	15.5	4-6	***	65-75

\*The minimum Marshall Stability for Type S mixes used on limited access facilities (Interstate, Turnpike, and Expressways) shall be 1,800 lbs.  
\*\*The maximum Flow value during production shall not exceed one point more than shown in the Table.  
\*\*\*The ratio of the percentage by weight of total aggregate passing the No. 200 sieve to the effective asphalt content expressed as a percentage by weight of total mix shall be in the range of 0.6 to 1.2.

Table 331-2 SI Units Marshall Design Properties For Bituminous Concrete Mixes						
Mix Type	Minimum Marshall Stability (kN)	Flow** (mm)	Minimum VMA (%)	Air Voids (%)	Minimum Effective Asphalt Content (%)	VFA Voids Filled with Asphalt (%)
S-I	6.7*	2.0-3.3	14.5	4-5	***	65-75
S-II	6.7*	2.0-3.3	13.5	4-5	***	65-75
S-III	6.7*	2.0-3.3	15.5	4-6	***	65-75
Type II	2.2-3.3	1.8-3.8	18	5-16	6.0	-
Type III	3.3-4.4	1.8-3.8	15	5-12	5.5	-
SAHM	1.3-2.2	1.8-3.8	15	5-16	6.0	-
ABC-1	2.2	1.8-3.8	15	5-16	6.0	-
ABC-2	3.3	1.8-3.8	15	5-14	5.5	-
ABC-3	4.4	2.0-3.3	14	4-7	***	65-78
FC-2	-	-	-	-	-	-
FC-3	6.7	2.0-3.3	15.5	4-6	***	65-75

\*The minimum Marshall Stability for Type S mixes used on limited access facilities (Interstate, Turnpike, and Expressways) shall be 8.0 kN.  
\*\*The maximum Flow value during production shall not exceed 0.25 mm more than shown in the Table.  
\*\*\*The ratio of the percentage by weight of total aggregate passing the 75µm sieve to the effective asphalt content expressed as a percentage by weight of total mix shall be in the range of 0.6 to 1.2.

The Engineer will accept the work on a LOT to LOT basis in accordance with the applicable requirements of Sections 5, 6, and 9. The size of the LOT will be as specified in 331-6 for the bituminous mixture produced at the plant and as stipulated in 331-7 for the material placed on the roadway.

**331-1.2 Layer Thicknesses:**

**331-1.2.1 Structural Layers:** The allowable layer thicknesses for Type S Asphalt Concrete mixtures used in structural and overbuild applications is as follows:

Type S-III..... 3/4 – 1 1/4 inches [20 – 30 mm]

Type S-I ..... 1 1/4 – 2 1/2 inches [30 – 60 mm]

Type S-II..... 2 – 2 3/4 inches [50 – 70 mm]

In addition to the minimum and maximum thickness requirements, the following restrictions are placed on Type S mixtures when used as a structural course:

Type S-III – Limited to the final (top) structural layer, one layer only.

Type S-I – May not be used in the first layer of courses over 3 1/2 inches [90 mm] thick, nor in the first layer of courses over 2 3/4 inches [70 mm] thick on limited access facilities.

Type S-II – May not be used in the final (top) structural layer.

**331-1.2.2 Additional Requirements:** The following requirements also apply to Type S Asphalt Concrete mixtures:

1. A minimum 1 1/2 inch [40 mm] initial lift is required over an Asphalt Rubber Membrane Interlayer (ARMI).

2. When construction includes the paving of adjacent shoulders (#5 feet [#1.5 m] wide), the layer thickness for the upper pavement layer and shoulder shall be the same and paved in a single pass, unless shown differently in the plans.

3. All overbuild layers shall be Type S asphalt concrete. Use the minimum and maximum layer thicknesses as specified in 331-1.2.1 unless shown differently in the plans. On variable thickness overbuild layers, the minimum allowable thickness may be reduced by 1/2 inch [13 mm], and the maximum allowable thickness may be increased 1/2 inch [13 mm], unless shown differently in the plans. Other variations from these thicknesses must be approved by the Engineer.

## **331-2 Materials.**

**331-2.1 General Requirements:** Meet the material requirements specified in Division III. Specific references are as follows:

Superpave PG Asphalt Binder or Recycling Agent ..... 916-1, 916-2

Mineral Filler ..... 917-1, 917-2

Coarse Aggregate, Stone, Slag or Crushed Gravel ..... Section 901

Fine Aggregate ..... Section 902

Asphalt concrete mixes containing crushed gravel as coarse aggregate component must show no potential for stripping during laboratory testing for mix design verification.

Crushed Reclaimed Portland Cement Concrete Pavement may be used as a coarse aggregate or screenings component subject to meeting all applicable specifications.

### **331-2.2 Specific Requirements:**

**331-2.2.1 Condition of Aggregate:** Use clean aggregate containing no deleterious substances. Do not use coarse or fine aggregate which contains more than 0.5% of phosphate.

**331-2.2.2 Fine Aggregate and Mineral Filler:** In laboratory tests, and for the purpose of proportioning the paving mixture, consider all material passing the No. 10 [2.00 mm] sieve and retained on the No. 200 [75 µm] sieve as fine aggregate, and the material passing the No. 200 [75 µm] sieve as mineral filler.

**331-2.2.3 Screenings:** Do not use any screenings in the combination of aggregates containing more than 15% of material passing the No. 200 [75 µm] sieve. When two screenings are blended to produce the screening component of the aggregate, one of such screenings may contain up to 18% of material passing the No. 200 [75 µm] sieve, as long as the combination of the two does not

contain over 15% material passing the No. 200 [75 µm] sieve. Screenings may be washed to meet these requirements.

**331-2.2.4 Use of Reclaimed Asphalt Pavement (RAP):** Subject to certain requirements, Reclaimed Asphalt Pavement (RAP) may be used as a component material of the asphalt mixture. Where the material is recovered from a FDOT project, the Composition of Existing pavement may be available on the Department's web site. The URL for obtaining this information, if available, is: [www11.myflorida.com/statematerialsoffice/Bituminous/CentralBitLab/AsphaltCompositions/Compositions.htm](http://www11.myflorida.com/statematerialsoffice/Bituminous/CentralBitLab/AsphaltCompositions/Compositions.htm)

RAP may be used as a component material of the bituminous mixture subject to the following:

1. Assume responsibility for the design of asphalt mixes which incorporate RAP as a component part.
2. Do not allow RAP to exceed 60% by weight of total aggregates for Asphalt Base Courses nor more than 50% by weight of total aggregates for Structural and Leveling Courses. Do not use RAP in Friction Courses.
3. Mount a grizzly or grid with openings of a sufficient size to prevent clogging of the cold feed over the RAP cold bin.

Use a grizzly or grid over the RAP cold bin, in-line roller crusher, screen, or other suitable means to prevent oversized RAP material from showing up in the completed recycled mixture.

If oversized RAP material appears in the completed recycled mix, cease plant operations and take appropriate corrective action.

4. Ensure that the RAP material as stockpiled is reasonably uniform in characteristics and contains no aggregate particles which are soft or conglomerates of fines.
5. Ensure that the RAP has a minimum average asphalt content of 4% by weight of total mix. The Department reserves the right to sample the stockpile in order that this requirement is met.

When material milled from the project is used as a component of the asphalt mixture and a Composition of Existing Pavement is known, use the following procedures for obtaining representative samples for the mix design:

1. Cut ten 6-inch [150 mm] cores in area(s) approved by the Engineer. Fill the core holes immediately prior to opening to traffic.
2. Representative samples may also be obtained by milling the existing pavement to the full depth shown on the plans for pavement removal for a length of approximately 200 feet [60 m]. Immediately replace the pavement removed with the specified mix in the Contract.
3. Submit a request in writing to the Engineer for any variance from the above outlined methods of obtaining samples for mix designs.

When the RAP to be used as a component in a mix design is stockpiled from a previous DOT project and the Composition of Existing Pavement is known, design the mix and submit to the Department for verification.

When the composition of stockpiled RAP to be used as a component in a mix design is not known, design the mix as follows:

1. Submit a bag of RAP, composed of samples from several locations in the stockpile(s), to the Department at least four weeks prior to the planned start of mix design. The Engineer will run viscosities on the reclaimed asphalt pavement and furnish the information to the Contractor.
2. Run a minimum of six extraction gradation analyses of the RAP. Take the samples at random locations around the stockpile(s).

3. Request the Engineer to make a visual inspection of the stockpile(s) of RAP. Based on visual inspection, the Engineer will determine the suitability of the stockpiled materials.

4. When the proposed mix design is submitted to the Department for verification, submit the data from the extraction gradation analyses required above.

**331-2.2.5 Binder for Mixes with RAP:** Use a PG 67-22 where RAP is less than 20% by weight of total aggregate; use a PG 64-22 where RAP is 20% or greater but less than 30% by weight of total aggregate; use appropriate recycle agent where RAP is 30% or greater.

The Engineer reserves the right to change binder type and grade at design based on the characteristics of the RAP binder, and reserves the right to request reasonable changes during the production based on the requirements of 331-4.4.4.

**331-2.2.6 Use of Recycled Crushed Glass:** Recycled crushed glass may be used as a component of the bituminous mixture subject to the following:

1. Consider the recycled crushed glass a local material and meet all requirements specified in 902-6.

2. The percentage of recycled crushed glass in any bituminous mixture does not exceed 15% of the total aggregate weight.

3. The asphalt binder used with mixtures containing recycled crushed glass contains 0.5% anti-stripping agent from an approved source. The addition of the specified amount of anti-stripping agent must be certified by the supplier.

4. Test bituminous mixtures containing recycled crushed glass in accordance with AASHTO T 283 as part of the mix design approval. The minimum tensile strength ratio must not be less than 80%. An increase in the amount of anti-stripping agent may be necessary in order to meet this requirement.

5. Recycled crushed glass must not be used in friction course mixtures nor in structural course mixtures which are to be used as the final wearing course.

### **331-3 Permissible Variation for the Coarse Aggregate.**

Size and uniformly grade or combine the aggregate or aggregates shipped to the job in such proportions that the resulting mixture meets the grading requirements of the mix design.

### **331-4 General Composition of Mixture.**

**331-4.1 General:** Use a bituminous mixture composed of a combination of aggregate (coarse, fine or mixtures thereof), mineral filler, if required, and bituminous material. Ensure that not more than 20% by weight of the total aggregate used is silica sand or local materials as defined in Section 902. Consider the silica sand and local materials contained in any RAP material, if used in the mix, in this limitation. Size, grade and combine the several aggregate fractions in such proportions that the resulting mixture meets the grading and physical properties of the verified mix design.

RAP meeting the requirements of 331-2.2.4 may be approved as a substitution for a portion of the combination of aggregates, subject to all applicable specification requirements being met.

**331-4.2 Grading Requirements:** In all cases, use a mix design within the design ranges specified in Table 331-1.

#### **331-4.3 Mix Design:**

**331-4.3.1 General:** Prior to the production of any asphalt paving mixture, submit a mix design and representative samples of all component materials to the Department at least two weeks before the scheduled start of production. The Engineer will verify the mix design before use. Send a copy of the proposed mix design to the Engineer at the same time. (Open-graded mixes will be designed by the Engineer.) Furnish the following information:

1. The specific project on which the mixture will be used.

2. The source and description of the materials to be used.

3. The gradation and approximate proportions of the raw materials as intended to be combined in the paving mixture. The gradation of the component materials shall be representative of the material at the time of use.

4. A single percentage of the combined mineral aggregate passing each specified sieve. Degradation of the aggregate due to processing (particularly No. 200 [75 µm]) should be accounted for and identified for the applicable sieves.

5. A single percentage of asphalt by weight of total mix intended to be incorporated in the completed mixture, shown to the nearest 0.1%. For structural mixes (S-I, S-II and S-III) establish the optimum asphalt content at a level corresponding to a minimum of 4.5% air voids. For FC-3 mixes, establish optimum asphalt content at a level corresponding to a minimum of 5.0% air voids.

6. A single temperature at which the mixture is intended to be discharged from the plant.

7. The laboratory density of the asphalt mixture for all mixes except Open-Graded Friction Courses.

8. Evidence that the completed mixture will meet all specified physical requirements.

9. The name of the individual responsible for the Quality Control of the mixture during production.

**331-4.3.2 Revision of Mix Design:** Submit all requests for revisions to approved mix designs, along with supporting documentation, in writing to the Engineer. In order to expedite the revision process, a verbal revision request or discussion of the possibility of a revision request may be made, but must be followed up with a written request. The verified mix design will remain in effect until a change is authorized by the Engineer. In no case will the effective date of the revision be established earlier than the date of the first communication with the Engineer regarding the revision.

Provide a new mix design for any change in source of aggregate.

**331-4.3.3 Resistance to Plastic Flow:** Include with the submitted mix design test data showing that the material as produced will meet the requirements specified in Table 331-2 when tested in accordance with FM 1-T 245. Further, determine the bulk specific gravity of the laboratory compacted bituminous mixture in accordance with FM 1-T 166.

Determine the percent of unfilled voids and the percent of aggregate voids filled with asphalt using the maximum specific gravity of the bituminous mixture and on the asphalt content of each group of specimens prepared from the same sample. Determine maximum specific gravity of the bituminous mixture by FM 1-T 209.

**331-4.3.4 Revocation of Mix Design:** The Engineer will consider any marked variations from original test data for a mix design or any evidence of inadequate field performance of a mix design as sufficient evidence that the properties of the mix design have changed, and the Engineer will no longer allow the use of the mix design.

#### **331-4.4 Contractor's Quality Control:**

**331-4.4.1 Personnel:** In accordance with the requirements of 331-5.2 provide the necessary quality control personnel. Ensure that the Quality Control Technician is certified by the Department and possesses a valid certificate of qualification. When it becomes evident to the Department that the Quality Control Technician cannot perform as required by the position, the Department will revoke the certification and require replacement with a certified technician.

**331-4.4.2 Extraction Gradation Analysis:** Sample the bituminous mixture at the plant in accordance with FM 1-T 168. Determine the percent bitumen content of the mixture in accordance with FM 5-563, and determine the percent passing the standard sieves in accordance with FM 1-T 030. In the event the calibration factor for the mix exceeds 0.50%, conduct the extraction and gradation analysis in accordance with FM 5-544 and FM 5-545, respectively. Show all test results to the nearest 0.01. Carry all



calculations to the nearest 0.001 and rounded to the nearest 0.01, in accordance with the Department's rules of rounding.

Run a minimum of one extraction gradation analysis of the mixture for each day's or part of a day's production and immediately following any change in the production process. Take the quality control sample of mixture for the extraction gradation analysis each day as soon as the plant operations have stabilized. Obtain the results in a timely manner (no later than the end of the day) so that adjustments can be made if necessary.

On initial use of a Type S or FC-3 mix design at a particular plant, as a minimum, run an additional extraction gradation analysis if more than 500 tons [450 metric tons] of mixture are produced on the first day of production.

Extraction gradation analysis will not be required on the days when mix production is less than 100 tons [90 metric tons]. However, when mix production is less than 100 tons [90 metric tons] per day on successive days, run the test when the accumulative tonnage on such days exceeds 100 tons [90 metric tons].

Use the target gradation and asphalt content as shown on the mix design. Any changes in target will require a change in the mix design in accordance with 331-4.3.2.

If the percentage of bitumen deviates from the optimum asphalt content by more than 0.55% or the percentage passing any sieve falls outside the limits shown in Table 331-3, make the necessary correction. If the results for two consecutive tests deviate from the optimum asphalt content by more than 0.55% or exceeds the limits as shown in Table 331-3 for any sieve, stop the plant operations until the problem has been corrected. In addition, if the results of two consecutive tests show an amount greater than 99.0% passing the 1/2 inch [12.5 mm] sieve for Type S-I, an amount greater than 99.0% passing the 3/4 inch [19.0 mm] sieve for Type S-II, or an amount greater than 99.0% passing the 3/8 inch [9.5 mm] sieve for Types S-III or FC-3, stop the plant operation until the problem has been corrected.

Maintain control charts showing the results of the extraction gradation analysis (bitumen content and sieve analysis).

Sieve Size	Percent Passing
1 inch [25.0 mm]	7
3/4 inch [19.0 mm]	7
1/2 inch [12.5 mm]	7
3/8 inch [9.5 mm]	7
No. 4 [4.75 mm]	7
No. 10 [2.00 mm]	5.5
No. 40* [*425 μm]	4.5
No. 80* [*180 μm]	3
No. 200 [75 μm]	2

\*Does not apply to SAHM, ABC-1 or Type II.

**331-4.4.3 Plant Calibration:** At or before the start of mix production, perform a wash gradation on a set of hot bin samples for batch or continuous mix plants or belt cut for drum mix plants to verify calibration of the plant. When approved by the Engineer, extraction gradation analysis of the mix may be used to verify calibration of the plant. This extraction gradation analysis may also be used to fulfill the quality control requirements for the first day's production.

**331-4.4.4 Viscosity of Asphalt in Mixes Containing RAP:** When RAP is a component material, the viscosity of the asphalt material in the bituminous mixture, determined by the Engineer in accordance with ASTM D 2171, shall be  $6,000 \pm 2,000$  poises [ $600 \pm 200$  Pa·s]. This determination will

be made on samples obtained by the Department on a random basis at a frequency of approximately one per 2,000 tons [1,800 metric tons] of mix.

If the viscosity determined by the Engineer is out of the specified range, adjust the binder formulation or blend of RAP in the mix to bring the viscosity within tolerance.

### **331-5 Acceptance Procedures.**

The Department will approve all materials for acceptance through the Department's Acceptance Procedures specified herein. The Engineer is responsible for determining the acceptability of the construction and materials incorporated therein. The Contractor is responsible for the quality of construction and materials incorporated therein. Accomplish all quality control sampling and testing on a random basis in accordance with the approved Quality Control Plan. The Department will perform all necessary sampling and testing for acceptance purposes on a random basis as specified herein, in addition to monitoring and observing the Contractor's quality control test procedures and results. Maintain effective quality control until final project acceptance.

A LOT is defined as an isolated quantity of a specified material produced from a single source or operation, or it is a measured amount of specified construction produced by the same process. In order to change the process, thereby necessitating the termination of the current LOT and starting a new LOT, submit a written request, with justification, to the Engineer for approval. Obtain the Engineer's approval prior to making the process change.

Perform all quality control sampling and testing of materials in strict conformance with the Florida Method of Sampling and Testing as found in the Field Sampling and Testing Manual. The Department will perform all acceptance sampling and testing of materials in strict conformance with the Florida Method of Sampling and Testing as found in the Field Sampling and Testing Manual. This manual, developed and distributed by the FDOT Materials Office, contains the detailed sampling and testing procedures from AASHTO and ASTM as modified by the Department.

#### **331-5.1 Acceptance Plans:**

**331-5.1.1 Payment Based on Acceptance Results:** The Department will adjust the payment for each LOT of material, product, item of construction or completed construction on the basis of acceptance test results in accordance with the requirements specified hereinafter in the applicable Sections.

**331-5.1.2 Resampling of LOTs:** The Department requires that LOTs of materials, products, items of construction or completed construction meet the requirements of these Specifications at the time of submission. The Department will not take check samples for acceptance purposes.

**331-5.1.3 Referee System:** The Department has established a referee system to verify the validity of the acceptance test results on LOTs at the asphalt plant. The Department will evaluate the acceptance test results with data from split samples run by the District and Central Labs. The Engineer will make a final determination and disposition of the acceptance test results. Acceptance results will be considered non-representative if the test results from the Field and Referee samples differ by more than 0.44% for asphalt content when obtained by the use of FM 5-563 or 0.56% for FM 5-544. Acceptance results for gradation will be considered non-representative if the test results from the Field and Referee samples differ by more than the precision values given in Figure 2 of FM 1-T 030 when using FM 5-563 or Figure 2 of FM 5-545 when using FM 5-544. When the referee analysis indicates that one or more test results are not representative, the Engineer will discard the non-representative test value(s) and base payment calculations for the LOT (including the subplot with the non-representative test values) on the remaining subplot(s) test data as defined in 331-6.

**331-5.2 Quality Control by the Contractor:** Provide and maintain a quality control system that provides reasonable assurance that all materials, products and completed construction submitted for acceptance meet Contract requirements. Develop and maintain a quality control system in conformance with the following requirements:

## **CONTRACTOR QUALITY CONTROL SYSTEM**

### **I. SCOPE:**

These Specifications establish minimum requirements and activities for a Contractor quality control system. These requirements pertain to the inspections and tests necessary to substantiate material and product conformance to Contract requirements and to all inspections and tests required by the Contract.

### **II. FUNCTIONS AND RESPONSIBILITIES:**

1. The Department. The Department will verify the Contractor's design mixes, inspect plants and monitor control of the operations to ensure conformance with these Specifications. The Department will design all open-graded friction mixes (FC-2 and FC-5).

At no time will the Engineer issue instructions to the Contractor or producer as to the setting of dials, gauges, scales and meters. However, the Department's representatives may question and warn the Contractor against the continuance of any operations or sequence of operations that obviously do not result in satisfactory compliance with the requirements of these Specifications.

2. The Contractor. Submit in writing the proposed Quality Control Plan for each asphalt plant for the Engineer's approval. Maintain the approved Quality Control Plan in effect for the plant to which it is assigned until the Engineer rejects it in writing. Include in the plan the sampling, testing, inspection and the anticipated frequencies of each to maintain process control. A recommended series of sampling, testing and inspecting activities are shown in Table 331-4.

Table 331-4
<b>RECOMMENDATIONS FOR A CONTRACTOR QUALITY CONTROL PLAN</b>

### **A. All Types of Plants**

#### **1. Stockpiles**

- a. Place materials in the correct stockpile.
- b. Use good stockpiling techniques.
- c. Inspect stockpiles for separation, contamination, segregation, etc.

#### **2. Incoming Aggregate**

- a. Obtain gradations and bulk specific gravity (BSG) values from the aggregate supplier.
- b. Determine gradation of all component materials.
- c. Compare gradations and BSG to mix design.

#### **3. Cold Bins**

- a. Calibrate the cold gate/feeder belt settings.
- b. Observe operation of cold feed for uniformity.

#### **4. Dryer**

- a. Observe pyrometer for aggregate temperature control.
- b. Observe efficiency of the burner.

#### **5. Hot Bins**

- a. Determine gradation of aggregates in each bin.
- b. Determine theoretical combined grading.

#### **6. Bituminous Mixture**

- a. Determine asphalt content.
- b. Determine mix gradation.
- c. Check mix temperature.
- d. Verify modifier addition.

## B. Batch Plants

1. For batch weights, determine percent used and weight to be pulled from each bin to ensure compliance with the mix design.
2. Check mixing time.
3. Check operations of weigh bucket and scales.

## C. Continuous Mix Plant

1. Determine gate calibration chart for each bin.
2. Determine gate settings for each bin to ensure compliance with the mix design.
3. Determine gallons [cubic meters] per revolution or gallons [cubic meters] per minute to ensure compliance with the mix design.

## D. Drum Mixer Plant

1. Calibrate the cold feed and prepare a calibration chart for each cold gate.
2. Develop information for the synchronization of the aggregate feed, reclaimed asphalt pavement (RAP) feed and the bituminous material feed.
3. Calibrate the weigh bridge on the changing conveyor.

The activities shown in Table 331-4 are the normal activities necessary to control the production of bituminous concrete at an acceptable quality level. The Department recognizes, however, that depending on the type of process or materials, some of the activities listed may not be necessary and, in other cases, additional activities may be required. The frequency of these activities will also vary with the process and the materials. When the process varies from the defined process average and variability targets, increase the frequency of these activities until the proper conditions are restored. Take one sample and test for every 1,000 tons [900 metric tons] of incoming aggregate (including RAP) as it is stockpiled. Test RAP material for extracted gradation and asphalt content.

Plot and keep up-to-date control charts for all quality control sampling and testing.

Provide control charts for the following:

- a. gradation of incoming aggregates
- b. gradation and asphalt content of RAP
- c. combined gradations of hot bins
- d. extracted asphalt content
- e. mix gradation
- f. gradation of cold feed (drum mixers)

Post all current control charts in the asphalt lab where they can be seen.

Formulate all design mixes with the exception of open-graded friction mixes (FC-2 and FC-5). Submit design mixes to the Engineer for verification prior to their use. Provide process control of all materials during handling, blending, mixing and placing operations.

## III. QUALITY CONTROL SYSTEM:

1. General Requirements. Furnish and maintain a quality control system that provides reasonable assurance that all materials and products submitted to the Engineer for acceptance meet the Contract requirements. Perform, or have performed, the inspection and tests required to substantiate product conformance to Contract requirements, and also perform, or have performed, all inspections and tests otherwise required by the Contract. Keep a quality control technician, who has been certified by the Department as a Qualified Asphalt Plant Technician (Plant Level II), available at the asphalt plant at all times when producing asphalt mix for the Department. Place a person in responsible charge of the paving operations who is qualified by the Department as a Qualified Asphalt Paving Technician (Paving Level II). Document the quality control procedures, inspection and tests, and make that information available for review by the Engineer throughout the life of the Contract.

2. Documentation. Maintain adequate records of all inspections and tests. Record the nature and number of tests made, the number and type of deficiencies found, the quantities approved and rejected,

and the nature of corrective action taken, as appropriate. The Department may review and approve all documentation procedures prior to the start of the work. The Department will take ownership of all charts and records documenting the Contractor's quality control tests and inspections upon completion of the work.

3. Charts and Forms. Record all conforming and nonconforming inspections and test results on approved forms and charts, and keep them up to date and complete and make them available at all times to the Engineer during the performance of the work. Prepare charts of test properties for the various materials and mixtures on forms that are in accordance with the applicable requirements of the Department. The Engineer will furnish a copy of each applicable chart and form. Provide a supply of the charts and forms from the copy furnished. Obtain the Engineer's approval of non-standard forms and charts prior to using them.

4. Corrective Actions. Take prompt action to correct any errors, equipment malfunctions, process changes or other problems that result or could result in the submission of materials, products or completed construction that do not meet the requirements of these Specifications. When it becomes evident to the Department that the Contractor is not controlling his process and is making no effort to take corrective actions, the Department will require the Contractor to cease plant operations until such time as the Contractor can demonstrate that he can and is willing to control the process.

5. Laboratories with Measuring and Testing Equipment. Furnish a fully equipped asphalt laboratory (permanent or portable) at the production site, and meeting the following requirements:

a. Area - Provide an effective working area for the laboratory that is a minimum of 180 ft<sup>2</sup> [17 m<sup>2</sup>]. This area does not include the space for desks, chairs and file cabinets.

b. Lighting - Provide lighting in the lab adequate to illuminate all areas of work.

c. Temperature Control - Equip the lab with heating and air conditioning units that provide a satisfactory working environment.

d. Ventilation - Equip the lab with fume hoods and exhaust fans that will remove all hazardous fumes from within the laboratory in accordance with OSHA requirements.

e. Equipment and Supplies - Furnish the lab with the necessary sampling and testing equipment, and supplies, for performing Contractor quality control and Department acceptance sampling and testing. A detailed list of equipment and supplies required for each test is included in the Field Sampling and Testing Manual.

When running plants at a high production rate, furnish additional testing equipment as necessary to allow the completion of the Contractor's quality control tests and the Department's Acceptance tests within the specified time frame.

6. Sampling and Testing. Use the sampling and testing methods and procedures that the Department provides to determine quality conformance of the materials and products. The Department will use these same methods and procedures for its acceptance tests. Include the sampling for other material characteristics on a random basis and the plotting of the test results on control charts in the Quality Control Plan.

7. Alternative Procedures. The Contractor may use alternative sampling methods, procedures and inspection equipment when such procedures and equipment provide, as a minimum, the quality assurance required by the Contract Documents. Prior to applying such alternative procedures, describe them in a written proposal and demonstrate for the Engineer's approval that their effectiveness is equal to or better than the Contract requirements. In case of dispute as to whether certain proposed procedures provide equal assurance, use the procedures stipulated by the Contract Documents.

8. Nonconforming Materials. Establish and maintain an effective and positive system for controlling nonconforming materials, including procedures for identification, isolation and disposition. Reclaim or rework nonconforming materials in accordance with procedures acceptable to the Engineer. Discuss the details of this system at the preconstruction conference, and make these details a part of the record of the conference.

9. Department Inspection at Subcontractor or Supplier Facilities. The Department reserves the right to inspect materials not manufactured within the Contractor's facility. The Department's inspection does not constitute acceptance and does not, in any way, replace the Contractor's inspection or otherwise relieve the Contractor of his responsibility to furnish an acceptable material or product. When the Department inspects the subcontractor's or supplier's product, such inspection does not replace the Contractor's responsibility to inspect such subcontractor's or supplier's product.

Inspect subcontracted or purchased materials when received, as necessary, to ensure conformance to Contract requirements. Report to the Engineer any nonconformance found on Department source-inspected material, and require the supplier to take necessary corrective action.

### **331-5.3 Defective Materials:**

**331-5.3.1 Acceptance or Rejection:** Following the application of the appropriate acceptance plan, the Engineer will make the final decision as to the acceptance, rejection or acceptance at an adjusted payment of the LOTs.

**331-5.3.2 Disposition of LOTs:** For nonconforming LOTs of materials, products, items of construction or complete construction that are not adaptable to correction by reworking, either remove and replace the nonconforming work, or accept no payment or an adjusted payment as stated in these Specifications, or, if not stated, as directed by the Engineer.

**331-5.4 General Basis of Adjusted Payment For Deficiencies:** When the Engineer determines that a deficiency exists, the Engineer will apply the applicable payment factor as shown in these Specifications to the entire LOT. When the Engineer determines that multiple deficiencies exist, the Engineer will apply an adjustment to the LOT of material that is identified by each deficiency. The Engineer will apply the adjustment for each deficiency separately as it occurs. The Engineer will not allow an adjustment to be affected by any other adjustment occurring for the same LOT. As an exception to the foregoing requirements, when there are two or more deficiencies in the gradation acceptance tests (% pass No. 4 [4.75 mm] sieve, % pass No. 10 [2.0 mm] sieve, % pass No. 40 [425 µm sieve], % pass No. 200 [75 µm] sieve) the Engineer will only apply the greater adjustment. The Engineer will express all reductions in payment in terms of equivalent pay items at no pay. When the item is measured by the ton [metric ton], the Engineer will convert the LOT in the field, which is measured in feet [meters], to equivalent tons [metric tons] and by using the average calculated spread for that LOT. When the pay item is measured by the square yard [square meter], the Engineer will convert the LOT at the production point, which is measured in tons [metric tons], to equivalent square yards [square meters] at the design thickness and by using the laboratory density as a conversion factor.

## **331-6 Acceptance of the Mixture at the Plant.**

**331-6.1 General:** The Engineer will accept the bituminous mixture at the plant, with respect to gradation and asphalt content, on a LOT to LOT basis. The material will be tested for acceptance in accordance with the provisions of 331-5 and the following requirements. However, the Engineer will reject any load or loads of mixture which are unacceptable for reason of being excessively segregated, aggregates improperly coated, or of excessively high or low temperature for use in the work.

For initial use of a Type S or FC-3 mix design with a Florida limestone source north of the 28th parallel at a particular plant, limit the first day's production to a maximum of 300 tons [275 metric tons]. Resume production upon notification of acceptable Marshall properties as determined in accordance with 331-6.4

A standard size LOT at the asphalt plant will consist of 4,000 tons [3,600 metric tons] with four equal sublots of 1,000 tons [900 metric tons] each. As an exception, the first LOT for the initial use of a Type S or FC-3 mix design with a particular plant will consist of four sublots, the first subplot of 500 tons [450 metric tons] or the first day's production (300 tons [275 metric tons] maximum for mix design with a Florida limestone source north of the 28th parallel), the second subplot of 500 tons [450 metric tons], and the remaining two sublots of 1,000 tons [900 metric tons] each.

A partial LOT may occur due to the following:

- (1) the completion of a given mix type on a project.
- (2) an approved LOT termination by the Engineer due to a change in process, extended delay in production, or change in mix design.

If the partial LOT contains one or two sublots with their appropriate test results, then the previous full-size LOT will be redefined to include this partial LOT and the evaluation of the LOT will be based on either five or six subplot determinations. If the partial LOT contains three sublots with their appropriate test results, this partial LOT will be redefined to be a whole LOT and the evaluation of it will be based on three subplot determinations.

When the total quantity of any mix is less than 3,000 tons [2,700 metric tons], the partial LOT will be evaluated for the appropriate number of sublots from n=1 to n=3. When the total quantity of any mix type is less than 500 tons [450 metric tons], the Department will accept the mix on the basis of visual inspection. The Department may run extraction and gradation analysis for information purposes; however, the provisions for partial payment will not apply.

On multiple project contracts, the LOT(s) at the asphalt plant will carry over from project to project.

**331-6.2 Acceptance Procedures:** Control all operations in the handling, preparation, and mixing of the asphalt mix so that the percent bitumen and the percents passing the No. 4, No. 10, No. 40 and No. 200 [4.75 mm, 2.00 mm, 425 µm and 75 µm] sieves will meet the approved job mix formula within the tolerance shown in Table 331-6.

Table 331-6 Tolerances for Acceptance Tests	
Characteristic	Tolerance*
Asphalt Content (Extraction)	±0.55%
Asphalt Content (Printout)	±0.15%
Passing No. 4 [4.75 mm] sieve	±7.00%
Passing No. 10 [2.00 mm] sieve	±5.50%
Passing No. 40 [425 µm] sieve**	±4.50%
Passing No. 200 [75 µm] sieve	±2.00%

\*Tolerances for sample size of n=1. See Table 331-7 for other sample sizes n=2 through n=6.  
 \*\*Applies only to Types S-I, S-II, S-III, and FC-3.

Acceptance of the mixture will be on the basis of test results on consecutive random samples from each LOT. One random sample will be taken from each subplot. The bituminous mixture will be sampled and tested at the plant as specified in 331-4.4.2.

Calculations for the acceptance test results for bitumen content and gradation (percentages passing No. 4, No. 10, No. 40 and No. 200 [4.75 mm, 2.00 mm, 425 µm and 75 µm] sieves) will be shown to the nearest 0.01. Calculations for arithmetic averages will be carried to the nearest 0.001 and rounded to the nearest 0.01 in accordance with the Department's rules of rounding.

Payment will be made on the basis of Table 331-7, "Acceptance Schedule of Payment". The process will be considered out of control when the deviation of any individual test result from the mix design falls in the 80% pay factor for the "one test" column of Table 331-7. When this happens, the LOT will be automatically terminated and production stopped. The approval of the Engineer will be required prior to resuming production of the mix. Acceptance of the LOT will then be determined in accordance with Table 331-7.

All acceptance tests will be completed on the same day the sample was taken, when possible, and on no occasion will they be completed later than the following work day.

Table 331-7 Acceptance Schedule of Payment (Asphalt Plant Mix Characteristics)						
Average of Accumulated Deviations of the Acceptance Tests from the Mix Design.						
Pay Factor	1-Test	2-Tests	3-Tests	4-Tests	5-Tests	6-Tests
Asphalt Cement Content (Extraction - FM 5-544 or 5-563)						
1.00	0.00-0.55	0.00-0.43	0.00-0.38	0.00-0.35	0.00-0.33	0.00-0.31
0.95	0.56-0.65	0.44-0.50	0.39-0.44	0.36-0.40	0.34-0.37	0.32-0.36
0.90	0.66-0.75	0.51-0.57	0.45-0.50	0.41-0.45	0.38-0.42	0.36-0.39
0.80*	over 0.75	over 0.57	over 0.50	over 0.45	over 0.42	over 0.39
Asphalt Cement Content (Printout)						
1.00	0.00-0.15	0.00-0.15	0.00-0.15	0.00-0.15	0.00-0.15	0.00-0.15
0.95	0.16-0.25	0.16-0.25	0.16-0.25	0.16-0.25	0.16-0.25	0.16-0.25
0.90	0.26-0.35	0.26-0.35	0.26-0.35	0.26-0.35	0.26-0.35	0.26-0.35
0.80*	over 0.35	over 0.35	over 0.35	over 0.35	over 0.35	over 0.35
No. 4 [4.75 mm] sieve**						
1.00	0.00-7.00	0.00-5.24	0.00-4.46	0.00-4.00	0.00-3.68	0.00-3.45
0.98	7.01-8.00	5.25-5.95	4.47-5.04	4.01-4.50	3.69-4.13	3.46-3.86
0.95	8.01-9.00	5.96-6.66	5.05-5.62	4.51-5.00	4.14-4.58	3.87-4.27
0.90	9.01-10.00	6.67-7.36	5.63-6.20	5.01-5.50	4.59-5.02	4.28-4.67
0.80*	over 10.00	over 7.36	over 6.20	over 5.50	over 5.02	over 4.67
No. 10 [2.00 mm] sieve**						
1.00	0.00-5.50	0.00-4.33	0.00-3.81	0.00-3.50	0.00-3.29	0.00-3.13
0.98	5.51-6.50	4.34-5.04	3.82-4.39	3.51-4.00	3.30-3.74	3.14-3.54
0.95	6.51-7.50	5.05-5.74	4.40-4.96	4.01-4.50	3.75-4.18	3.55-3.95
0.90	7.51-8.50	5.75-6.45	4.97-5.54	4.51-5.00	4.19-4.63	3.96-4.36
0.80*	over 8.50	over 6.45	over 5.54	over 5.00	over 4.63	over 4.36
No. 40 [425 µm] sieve**						
1.00	0.00-4.50	0.00-3.91	0.00-3.65	0.00-3.50	0.00-3.39	0.00-3.32
0.98	4.51-5.50	3.92-4.62	3.66-4.23	3.51-4.00	3.40-3.84	3.33-3.72
0.95	5.51-6.50	4.63-5.33	4.24-4.81	4.01-4.50	3.85-4.29	3.73-4.13
0.90	6.51-7.50	5.34-6.04	4.82-5.39	4.51-5.00	4.30-4.74	4.14-4.54
0.80*	over 7.50	over 6.04	over 5.39	over 5.00	over 4.74	over 4.54
No. 200 [75µm] sieve**						
1.00	0.00-2.00	0.00-1.71	0.00-1.58	0.00-1.50	0.00-1.45	0.00-1.41
0.95	2.01-2.40	1.72-1.99	1.59-1.81	1.51-1.70	1.46-1.63	1.42-1.57
0.90	2.41-2.80	2.00-2.27	1.82-2.04	1.71-1.90	1.64-1.80	1.58-1.73
0.80*	over 2.80	over 2.27	over 2.04	over 1.90	over 1.80	over 1.73
*If approved by the Engineer based on an engineering determination that the material is acceptable to remain in place, the Contractor may accept the indicated partial pay. Otherwise, remove and replace the material at no cost to the Department at any item.						
**When there are two or more reduced payments for these items in one LOT of material, only the greatest reduction in payment will be applied. CAUTION: This rule applies only to these four gradation test results.						
NOTES:						
(1) The No. 40 [425 µm] sieve applies to Type S-I, S-II, S-III and FC-3.						
(2) Deviations are absolute values with no plus or minus signs.						

**331-6.3 Automatic Batch Plant With Printout:** Acceptance determinations for asphalt content for mixtures produced by automatic batch plants with printout will be based on the calculated bitumen



content using the printout of the weights of asphalt actually used. Acceptance determinations for gradations (No. 4, No. 10, No. 40 and No. 200 [4.75 mm, 2.00 mm, 425  $\mu\text{m}$  and 75  $\mu\text{m}$ ] sieves) will be based on the actual test results from extraction gradation analyses. Payment will be made based on the provisions of Table 331-7.

**331-6.4 Additional Tests:** The Engineer reserves the right to run any test at any time for informational purposes and for determining the effectiveness of the Contractor's quality control.

**331-6.4.1 Determination of Marshall and Volumetric Properties:** The Engineer will determine the Marshall and Volumetric Properties of the mix at a minimum frequency of one set per LOT, to determine whether or not the produced mix is meeting the specification requirements. The Department will sample and prepare test specimens and test them in accordance with FM 5-511 for Marshall stability and flow, FM 1-T 209 for maximum specific gravity, and FM 1-T 166 for density. Volumetric properties will be determined for Type S and FC-3 mixes only.

**331-6.4.2 Failing Marshall Properties:** When the average value of the specimens fails to meet specification requirements for stability or flow, the Engineer may stop the plant operations until all specification requirements can be met or until another verified mix design has been approved. Make revisions to a mix design in accordance with 331-4.3.2. If the Lab Density of the mix during production differs from the value shown on the verified mix design by more than 2 lbs/ft<sup>3</sup> [32 kg/m<sup>3</sup>] for two consecutive tests, the Engineer will revise the target value.

**331-6.4.3 Failing Volumetric Properties (Type S and FC-3 mixes only):** When the Engineer determines the air void content to be less than 3.0%, or greater than 6.5%, make appropriate adjustments to the mix. When the air void content is determined to be less than 2.5% or greater than 7.0% on any one test, or less than 3.0% on two consecutive tests, cease operations until the problem has been resolved.

**331-6.4.4 Resuming Production:** In the event that plant operations are stopped due to a failure to meet specification requirements, obtain the Engineer's approval before resuming production of the mix. Limit production to a maximum of 300 tons [270 metric tons]. At this time, the Marshall and volumetric properties of the mix will be verified. After the Marshall and volumetric properties are verified, full scale production of the mix may be resumed.

**331-6.5.5 Disposition of In-Place Material:** Any material in-place that is represented by the failing test results (low stability, high flow, or less than 2.5% air voids) will be evaluated by the Engineer to determine if removal and replacement is necessary. Remove and replace any in-place material, if required, at no cost to the Department.

### **331-7 Acceptance of the Mixture at the Roadway**

**331-7.1 Density Control Nuclear Method:** Determine the in-place density of each course of asphalt mix construction using the Nuclear Density Backscatter Method as specified by FM 1-T 238 (Method B). For a completed course, obtain an average in-place LOT density of at least 98% of the valid control strip density.

Do not perform density testing on patching courses, leveling and intermediate courses less than 1 inch [25 mm] thick (or a specified spread rate less than 100 lb/yd<sup>2</sup> [55kg/m<sup>2</sup>]), overbuild courses where the minimum thickness is less than 1 inch [25 mm], projects less than 1,000 feet [300 m], sections with variable width, or open-graded friction courses. Compact these courses, with the exception of open-graded friction courses in accordance with 330-10.1.2.

**331-7.2 Control Strips:** In order to determine the density of compacted asphalt mixtures for the purpose of acceptance, first establish a control strip. Construct one or more control strips for the purpose of determining the control strip density. Construct a control strip at the beginning of asphalt construction and one thereafter for each successive course. Construct a new control strip for any change in the composition of the mix design, underlying pavement structure, compaction equipment, or procedures. The Engineer may require an additional control strip when the Engineer deems it necessary to establish a new

control strip density or confirm the validity of the control strip density being used at that time. The Contractor may also request a confirmation of the control strip density. Construct the control strip as a part of a normal day's run.

Construct a control strip 300 feet [100 m] in length and of an adequately uniform width to maintain a consistent compactive effort throughout the section. When constructing the control strip, start it between 300 and 1,000 feet [100 and 300 m] from the beginning of the paving operation. Construct a control strip of a thickness that is the same as that specified for the course of which it is a part. Construct the control strip using the same mix, the same paving and rolling equipment, and the same procedures as those used in laying the asphalt course of which the control strip is to become a part. Leave every control strip in place to become a portion of the completed roadway.

In order to determine the acceptability of the control strip, make ten nuclear density determinations at random locations within the control strip after completing the compaction of the control strip. Do not make any determinations within 12 inches [300 mm] of any unsupported edge. Use the average of these ten determinations for the Control Strip Density. For purposes of determining the percent of laboratory density, as required in Table 331-8, the Engineer will develop a correction factor at four nuclear density locations from 6 inch [150 mm] diameter cores or by direct transmission nuclear determination where applicable. Cut the cores prior to opening the roadway to traffic. The Engineer will calculate the percent of lab density to the nearest 0.01% and round it to the nearest 0.1%. Should the percent of lab density in a control strip exceed 99.0%, notify the Engineer immediately.

In the event that a control strip does not meet the minimum density requirements specified in Table 331-8, take appropriate corrective actions and construct a new control strip. If three consecutive control strips fail to meet specification requirements, the Engineer will limit production and placement of the mix to 800 to 1,000 feet [250 to 300 m], regardless of the thickness and width the Contractor is placing, until the Contractor obtains a passing control strip.

Once the Contractor has obtained a passing control strip after a failing control strip (for the same mix, layer, and project), the Department will use the passing control strip to accept all previously laid mix. In the event the Contractor does not obtain a passing control strip, and this particular mix, layer, etc., is completed on the project, the Engineer will evaluate density in accordance with FM 5-543.

Mix Type	Density	Minimum Control Strip Density* (% of Lab Density)	Surface Tolerance
S-I, S-II, S-III, Type II, Type III, SAHM	per 331-7	96	per 330-12
ABC-1, ABC-2, ABC-3	per 280-8.6	96	per 200-7
FC-2	No density required	N/A	per 330-12
FC-3	per 331-7	96	per 330-12

\* The minimum control strip density requirement for shoulders is 95% of lab density.

**331-7.3 LOTs:** For the purpose of acceptance and partial payment, the Engineer will divide each day's production into LOTs. The Engineer will close out all LOTs at the end of the day. The standard size of a LOT is 5,000 feet [1,500 m] of any pass made by the paving train regardless of the width of the pass or the thickness of the course. A subplot will be 1,000 feet [300 m] or less. The Engineer will consider pavers traveling in echelon as two separate passes. When at the end of a production day, the completion

of a given course, layer, or mix, or at the completion of the project, and a LOT size is determined to be less than 5,000 feet [1,500 m], it will be considered a partial LOT. Handle partial LOTs as follows:

If the length of the partial LOT is 2,000 feet [600 m] or less, and a previous full-size LOT from the same day, mix, layer, and project is available, then the previous full-size LOT will be redefined to include this partial LOT and the number of tests required for the combined LOT will be as shown in Table 331-9.

If the partial LOT is 2,000 feet [600 m] or less, and a previous full-size LOT from the same day, mix, layer, and project is not available, the Engineer will evaluate the partial LOT separately and perform the number of tests required for the partial LOT as shown in Table 331-9.

If the partial LOT is greater than 2,000 feet [600 m] long, the Engineer will evaluate the partial LOT separately and perform the number of tests required for the partial LOT as shown in Table 331-9.

Table 331-9	
Testing Requirements for Partial LOTs	
LOT Size	Number of Tests
Less than 3,000 feet [900 m]	3
3,001 to 4,000 feet [901 to 1,200 m]	4
4,001 to 5,000 feet [1,201 to 1,500 m]	5
5,001 to 6,000 feet [1,501 to 1,800 m]	6
6,001 to 7,000 feet [1,801 to 2,100 m]	7
Greater than 7,000 feet [2,100 m]	2 LOTs

For each LOT and partial LOT, the Engineer will make density determinations at a frequency shown in Table 331-9 at random locations within the LOT, but will not take them within 12 inches [300 mm] of any unsupported edge. The Engineer will determine the random locations by the use of statistically derived stratified random number tables. For the Contractor to receive full payment for density, the average density of a LOT shall be a minimum of 98.0% of the control strip density. Once the Engineer determines the average density of a LOT, do not provide additional compaction to raise the average. Notify the Engineer should the average density for two consecutive LOTs be greater than 102% of control strip density.

**331-7.4 Acceptance:** The Engineer will accept the completed pavement with respect to density on a LOT basis. The Department will make partial payment for those LOTs that have an average density less than 98.0% of the Control Strip Density based on Table 331-10:

Table 331-10	
Payment Schedule For Density	
Percent of Control Strip Density*	Percent of Payment
98.0 and above	100
97.0 to less than 98.0	95
96.0 to less than 97.0	90
Less than 96.0**	75

\* In calculating the percent of control strip density, do not round off the final percentage.  
 \*\* If approved by the Engineer, based on an engineering determination that the material is acceptable to remain in place, the Contractor may accept the indicated partial pay; otherwise, remove and replace the material at no expense to the Department. The Contractor may remove and replace the material at no expense to the Department at any time.

**331-7.5 Density Requirements for Small Projects and Other Non-mainline Roadway Areas:**  
 For projects less than 1,000 feet [300 m] in length and bridge projects with approaches less than 1,000

feet [300 m] each side, do not apply the requirements for control strips and nuclear density determination. Use the standard rolling procedures as specified in 330-10.1.2. Do not apply the provisions for partial payment to these small projects.

In other non-mainline roadway areas where it is not practical to establish a control strip, such as parking areas, toll plazas, turn lanes, and acceleration/deceleration lanes, the Contractor may use the standard rolling procedure to determine density requirements if so authorized in writing by the Engineer.

**331-7.6 Surface Tolerance:** The bituminous mixture will be accepted on the roadway with respect to surface tolerance in accordance with 330-12.

**331-8 Method of Measurement.**

The quantity to be paid for will be the weight of the mixture, in tons [metric tons], completed and accepted. The weight will be determined as provided in 320-2 (including the provisions for the automatic recordation system).

The bid price for the asphalt mix will include the cost of the liquid asphalt or the asphalt recycling agent. There will be no separate payment or unit price adjustment for the bituminous material in the asphalt mix.

**331-9 Basis of Payment:**

Price and payment will be full compensation for all the work specified under this Section, including the applicable requirements of Sections 320 and 330.

Payment will be made under:

- |          |          |   |
|----------|----------|---|
| Item No. | 331- 2-  | Type S Asphaltic Concrete - per ton.        |
| Item No. | 2331- 2- | Type S Asphaltic Concrete - per metric ton. |

## SECTION 430 PIPE CULVERTS

### 430-1 Description.

Furnish and install drainage pipe and end sections at the locations called for in the Plans. Furnish and construct joints and connections to existing pipes, catch basins, inlets, manholes, walls, etc., as may be required to complete the work.

Meet the requirements of 449-1.

Construct structural plate pipe culverts or underdrains in accordance with Sections 435 and 440.

For pipe culverts installed by jack & bore, install in accordance with Section 556.

### 430-2 Materials.

**430-2.1 Pipe:** Meet the following requirements:

Concrete Pipe .....	Section 449
Round Rubber Gaskets .....	Section 942
<del>Corrugated Steel Pipe and Pipe Arch .....</del>	<del>Section 943</del>
<del>Corrugated Aluminum Pipe and Pipe Arch .....</del>	<del>Section 945</del>
Corrugated Polyethylene Pipe .....	Section 948
<del>Steel Reinforced Polyethylene Ribbed Pipe .....</del>	<del>Section 948</del>
Corrugated Polypropylene Pipe .....	Section 948
<del>Corrugated Polyvinyl Chloride (PVC) Pipe .....</del>	<del>Section 948</del>
<del>Fiberglass Reinforced Polymer Pipe .....</del>	<del>Section 948</del>
<del>Liner Repair Systems .....</del>	<del>Section 948</del>

**430-2.2 Joint Materials:** Use joint materials specified in 430-7 through 430-9 according to type of pipe and conditions of usage.

**430-2.3 Mortar:** Use mortar composed of one part Portland cement and two parts of clean, sharp sand, to which mixture the Contractor may add hydrated lime in an amount not to exceed 15% of the cement content. Use mortar within 30 minutes after its preparation.

### 430-3 Type of Pipe to Be Used.

**430-3.1 General:** During the preconstruction conference, notify the Department in writing as to which optional pipe material from the optional materials tabulation sheet will be used. Once a pipe material is selected, do not change pipe materials without approval of the Engineer.

When the Plans designate a type (or types) of pipe, use only the type (or choose from the types) designated. As an exception, when the Plans designate reinforced concrete pipe as Class S, Class I, Class II, Class III and Class IV, the Contractor may use non-reinforced concrete pipe up to and including 36 inch in diameter.

**430-3.2 Side Drain:** If the Plans do not designate a type (or types) of pipe, the Contractor may use either a minimum Class I concrete pipe, corrugated steel pipe, corrugated aluminum pipe, corrugated polyethylene pipe, polypropylene pipe, or PVC pipe. If one of the metal types is chosen, use the minimum gage specified in Section 943 for steel pipe or Section 945 for aluminum pipe. When extending existing pipes, construct the pipe extensions of the same size and kind as the existing pipe. Extensions of existing pipes, whose materials are no longer

produced, shall be extended with the most similar pipe material available.

Non-reinforced concrete pipe may also be substituted for concrete pipe in side drains, subject to the provisions of 430-3.1.

#### **430-4 Laying Pipe.**

**430-4.1 General:** Lay all pipe, true to the lines and grades given, with hubs up and tongue end fully entered into the hub. When pipe with quadrant reinforcement or circular pipe with elliptical reinforcement is used, install the pipe in a position such that the manufacturer's marks designating "top" and "bottom" of the pipe are not more than five degrees from the vertical plane through the longitudinal axis of the pipe. Do not allow departure from and return to plan alignment and grade to exceed 1/16 inch per foot of nominal pipe length, with a total of not more than 1 inch departure from theoretical line and grade. Take up and relay any pipe that is not in true alignment or which shows any settlement after laying at no additional expense to the Department.

Do not use concrete pipe with lift holes except (1) round pipe which has an inside diameter in excess of 54 inches or (2) any elliptical pipe.

Repair lift holes, if present, with hand-placed, stiff, non-shrink, 1-to-1 mortar of cement and fine sand, after first washing out the hole with water. Completely fill the void created by the lift hole with mortar. Cover the repaired area with a 24 by 24 inch piece of filter fabric secured to the pipe. Use a Type D-3 filter fabric meeting the requirements specified in Section 985.

Secure the filter fabric to the pipe using a method that holds the fabric in place until the backfill is placed and compacted. Use grout mixtures, mastics, or strapping devices to secure the fabric to the pipe.

When installing pipes in structures, construct inlet and outlet pipes of the same size and kind as the connecting pipe shown in the Plans. Use the same pipe material within each continuous run of pipe. Extend the pipes through the walls for a distance beyond the outside surface sufficient for the intended connections, and construct the concrete around them neatly to prevent leakage along their outer surface as shown on Design Standards, Index No. 201. Keep the inlet and outlet pipes flush with the inside of the wall. Resilient connectors as specified in 942-3 may be used in lieu of a masonry seal.

Furnish and install a filter fabric jacket around all pipe joints and the joint between the pipe and the structure in accordance with Design Standards, Index Nos. 201 and 280. Use fabric meeting the physical requirements of Type D-3 specified in Section 985. Extend the fabric a minimum of 12 inches beyond each side of the joint or both edges of the coupling band, if a coupling band is used. The fabric must have a minimum width of 24 inches, and a length sufficient to provide a minimum overlap of 24 inches. Secure the filter fabric jacket against the outside of the pipe by metal or plastic strapping or by other methods approved by the Engineer.

Meet the following minimum joint standards:

Pipe Application	Minimum Standard
Storm and Cross Drains	Water-tight
Gutter Drain	Water-tight
Side Drains	Soil-tight

When rubber gaskets are to be installed in the pipe joint, the gasket must be the sole element relied on to maintain a tight joint. Soil tight joints must be watertight to 2 psi. Water-tight joints must be water-tight to 5 psi unless a higher pressure rating is required in the Plans.

**430-4.2 Trench Excavation:** Excavate the trench for storm and cross drains, and side drains as specified in Section 125.

**430-4.3 Foundation:** Provide a suitable foundation, where the foundation material is of inadequate supporting value, as determined by the Engineer. Remove the unsuitable material and replace it with suitable material, as specified in 125-8. Where in the Engineer's opinion, the removal and replacement of unsuitable material is not practicable, he may direct alternates in the design of the pipe line, as required to provide adequate support. Minor changes in the grade or alignment will not be considered as an adequate basis for extra compensation.

Do not lay pipe on blocks or timbers, or on other unyielding material, except where the use of such devices is called for in the Plans.

**430-4.4 Backfilling:** Backfill around the pipe as specified in 125-8 unless specific backfilling procedures are described in the Contract Documents.

**430-4.5 Plugging Pipe:** When existing pipe culverts are to be permanently placed out of service, fill them with flowable fill that is non-excavatable, contains a minimum 350 pounds per cubic yard of cementitious material and meets the requirements of Section 121 and/or plug them with masonry plugs as shown in the Plans. Install masonry plugs that are a minimum of 8 inches in thickness, in accordance with Design Standards, Index 280.

When proposed or existing pipe culverts are to be temporarily placed out of service, plug them with prefabricated plugs as shown in the Plans. Install prefabricated plugs in accordance with the manufacturer's recommendations. Do not fill or construct masonry plugs in any pipe culvert intended for current or future service.

**430-4.6 End Treatment:** Place an end treatment at each storm and cross drain, and side drain as shown in the Plans. Refer to the Design Standards for types of end treatment details. As an exception to the above, when concrete mitered end sections are permitted, the Contractor may use reinforced concrete U-endwalls, if shop drawings are submitted to the Engineer for approval prior to use.

Provide end treatments for corrugated polyethylene pipe, polypropylene pipe, and PVC pipe as specified in Section 948, or as detailed in the Plans.

**430-4.7 Metal Pipe Protection:** Apply a bituminous coating to the surface area of the pipe within and 12 inches beyond the concrete or mortar seal prior to sealing, to protect corrugated steel or aluminum pipe embedded in a concrete structure, such as an inlet, manhole, junction box, endwall, or concrete jacket.

Ensure that the surface preparation, application methods (dry film thickness and conditions during application), and equipment used are in accordance with the coating manufacturers' published specifications.

Obtain the Engineer's approval of the coating products used.

~~**430-4.8 Pipe Inspection:**~~ **This section is not applicable** lway, inspection is to be conducted when backfill reaches **to pipe installation in the** on completion of placement of the stabilized subgrade. For pipe **District.** embankments confined by walls, inspection is to be conducted when compacted embankment reaches 3 feet above the pipe crown or the finished earthwork grade as specified in the Plans. Prior to conducting the inspection, provide the Engineer with a video recording schedule for videoing, dewater installed

pipe, and remove all silt, debris and obstructions. Submit pipe videoing and reports to the Department for review prior to the continuation of paving.

For pipe 48 inches or less in diameter, provide the Engineer a video DVD and report using low barrel distortion video equipment with laser profile technology, non-contact video micrometer and associated software that provides:

1. Actual recorded length and width measurements of all cracks within the pipe.
2. Actual recorded separation measurement of all pipe joints.
3. Pipe ovality report.
4. Deflection measurements and graphical diameter analysis report in terms of x and y axis.
5. Flat analysis report.
6. Representative diameter of pipe.
7. Pipe deformation measurements, leaks, debris, or other damage or defects.
8. Deviation in pipe line and grade, joint gaps, and joint misalignment.
9. A video record of the actual speed at which the camera is traveling through the pipe, ensuring that the rate of travel does not exceed the limit defined in 430-4.8.1 below.

Laser profiling and measurement technology must be certified by the company performing the work to be in compliance with the calibration criteria posted at: <http://www.dot.state.fl.us/construction/contractorissues/laser.shtm> . Reports submitted in electronic media are preferred.

The Engineer may waive this requirement for side drains and cross drains which are short enough to inspect from each end of the pipe.

**430-4.8.1 Video Report:** Provide a high quality DVD in a MPEG2 format video with a standard resolution of 720 x 480. Use a camera with lighting suitable to allow a clear picture of the entire periphery of the pipe. Center the camera in the pipe both vertically and horizontally and be able to pan and tilt to a 90 degree angle with the axis of the pipe and rotating 360 degrees. Use equipment to move the camera through the pipe that will not obstruct the camera's view or interfere with proper documentation of the pipe's condition.

The video image shall be clear, focused, and relatively free from roll, static, or other image distortion qualities that would prevent the reviewer from evaluating the condition of the pipe. The video will include identification before each section of pipe filmed. The identification will include the project number, the structure number corresponding to the structure number in the Plans for the project, size of pipe, the date and time, and indicate which pipe is being filmed if multiple pipes are connected to the structure. Notes should be taken during the video recording process. Provide the Engineer with copies of these notes along with the video.

Move the camera through the pipe at a speed not greater than 30 feet per minute. Mark the video with the distance down the pipe. The distance shall have an accuracy of one foot per 100 feet. Film the entire circumference at each joint. Stop the camera and pan when necessary to document and measure defects. Position the camera head perpendicular to all defects requiring measurement by the video micrometer.

**430-4.8.2 Reinspection:** At any time after reviewing the submitted pipe inspection reports, the Engineer may direct additional inspections. If no defects are observed



during the reinspection, the Department will pay for the cost of the reinspections in accordance with 4-3. If defects are observed, the reinspection and all work performed to correct the defects will be done at no cost to the Department. Acceptance of all replacements or repairs will be based on video documentation of the completed work prior to Final Acceptance.

#### **430-5 Removing Existing Pipe.**

If the Plans indicate that existing pipe is to remain the property of the Department, collect and stack along the right-of-way all existing pipe or pipe arch so indicated in the Plans to be removed, or that does not conform to the lines and grades of the proposed work and that is not to be re-laid, as directed by the Engineer. Take care to prevent damage to salvageable pipe during removal and stacking operations.

#### **430-6 Placing Pipe Under Railroad.**

**430-6.1 General:** Construct pipe culverts under railroad tracks in accordance with the requirements of the railroad company.

Perform all the shoring under the tracks, and sheeting and bracing of the trench, required by the railroad company or deemed necessary by the Engineer in order to ensure safe and uninterrupted movement of the railroad equipment, at no expense to the Department.

**430-6.2 Requirements of the Railroad Company:** Install pipe using methods required by the railroad company and shown in the Contract Documents.

When the general method of installation required by the railroad company is indicated in the Plans, do not alter such method, or any other specific details of the installation which might be indicated in the Plans, without receiving approval or direction from the railroad, followed by written approval from the Engineer.

**430-6.3 Notification to Railroad Company:** Notify the railroad company and the Engineer at least ten days prior to the date on which pipe is to be placed under the railroad tracks.

**430-6.4 Placing Pipe by Jacking:** Obtain the Engineer's and the railroad company's approval of the details of the jacking method to be used, when placing pipe through the railroad embankment, before the work is started.

**430-6.5 Use of Tunnel Liner:** When the railroad company requires that a tunnel liner be used for placing the pipe in lieu of the jacking method, the Department will pay for the tunnel liner material separately in cases where the Contract Documents do not require the use of a tunnel liner. For these cases the Department will reimburse the Contractor for the actual cost of the liner, delivered at the site. The Department will base such cost on a liner having the minimum gage acceptable to the railroad.

#### **430-7 Specific Requirements for Concrete Pipe.**

**430-7.1 Sealing Joints:** Seal the pipe joints with round rubber or profile gaskets meeting the requirements of Section 449. Ensure that the gasket and the surface of the pipe joint, including the gasket recess, are clean and free from grit, dirt and other foreign matter, at the time the joints are made. In order to facilitate closure of the joint, application of a vegetable soap lubricant immediately before closing of the joint will be permitted. Prelubricated gaskets may be used in lieu of a vegetable soap lubricant when the lubricating material is certified to be inert with respect to the rubber material.

**430-7.2 Laying Requirements for Concrete Pipe with Rubber Gasket Joints:** Do not allow the gap between sections of pipe to exceed 5/8 inch for pipe diameters of 12 inches through 18 inches, 7/8 inch for pipe diameters of 24 through 66 inches, and 1 inch for pipe diameters 72 inches and larger. Where minor imperfections in the manufacture of the pipe create an apparent gap in excess of the tabulated gap, the Engineer will accept the joint provided that the imperfection does not exceed 1/3 the circumference of the pipe, and the rubber gasket is 1/4 inch or more past the pipe joint entrance taper. Where concrete pipes are outside of these tolerances, replace them at no expense to the Department. Do not apply mortar, joint compound, or other filler to the gap which would restrict the flexibility of the joint.

**430-7.3 Field Joints for Elliptical Concrete Pipe:** Use either a preformed plastic gasket material or an approved rubber gasket to make a field joint.

**430-7.3.1 Plastic Gasket:** Meet the following requirements when field joints are made from preformed plastic gasket material:

**430-7.3.1.1 General:** Install field joints in accordance with the manufacturer's instructions and the following:

**430-7.3.1.2 Material:** Meet the requirements of 942-2.

**430-7.3.1.3 Joint Design:** Ensure that the pipe manufacturer furnishes the Engineer with details regarding configuration of the joint and the amount of gasket material required to affect a satisfactory seal. Do not brush or wipe joint surfaces which are to be in contact with the gasket material with a cement slurry. Fill minor voids with cement slurry.

**430-7.3.1.4 Primer:** Apply a primer of the type recommended by the manufacturer of the gasket material to all joint surfaces which are to be in contact with the gasket material, prior to application of the gasket material. Thoroughly clean and dry the surface to be primed.

**430-7.3.1.5 Application of Gasket:** Apply gasket material to form a continuous gasket around the entire circumference of the leading edge of the tongue and the groove joint, in accordance with the detail shown on the Design Standards, Index No. 280. Do not remove the paper wrapper on the exterior surface of the gasket material until immediately prior to joining of sections. Apply plastic gasket material only to surfaces which are dry. When the atmospheric temperature is below 60°F, either store plastic joint seal gaskets in an area above 70°F, or artificially warm the gaskets to 70°F in a manner satisfactory to the Engineer.

**430-7.3.1.6 Installation of Pipe:** Remove and reposition or replace any displaced or contaminated gasket as directed by the Engineer. Install the pipe in a dry trench. Carefully shape the bottom of the trench to minimize the need for realignment of sections of pipe after they are placed in the trench. Hold to a minimum any realignment of a joint after the gaskets come into contact. Prior to joining the pipes, fill the entire joint with gasket material and ensure that when the pipes are joined there is evidence of squeeze-out of gasket material for the entire internal and external circumference of the joint. Trim excess material on the interior of the pipe to provide a smooth interior surface. If a joint is defective, remove the leading section of pipe and reseal the joint.

**430-7.3.2 Rubber Gasket:** Meet the following requirements when field joints are made with profile rubber gaskets:

**430-7.3.2.1 General:** Install field joints in accordance with the manufacturer's instructions and the following:

**430-7.3.2.2 Material:** Meet the requirements of 942-4.

**430-7.3.2.3 Joint Design:** Ensure that the pipe manufacturer furnishes the Engineer with details regarding configuration of the joint and gasket required to effect a satisfactory seal. Do not apply mortar, joint compound, or other filler which would restrict the flexibility of the gasket joint.

**430-7.4 Requirements for Concrete Radius Pipe:**

**430-7.4.1 Design:** Construct concrete radius pipe in segments not longer than 4 feet (along the pipe centerline), except where another length is called for in the Contract Documents. Join each segment using round rubber gaskets. Ensure that the pipe manufacturer submits details of the proposed joint, segment length and shape for approval by the Engineer, prior to manufacture.

**430-7.4.2 Pre-Assembly:** Ensure that the manufacturer pre-assembles the entire radius section in his yard, in the presence of the Engineer, to ensure a proper fit for all parts. At the option of the manufacturer, the Contractor may assemble the pipe without gaskets. Consecutively number the joints on both the interior and exterior surfaces of each joint, and make match marks showing proper position of joints. Install the pipe at the project site in the same order as pre-assembly.

~~**430-8 Specific Requirements for Corrugated Metal Pipe.**~~

**430-8.** This section is not applicable to pipe installation in the District. This material is not allowed.

When existing pipe to be extended is helically fabricated, make a field joint between the existing pipe and the new pipe using one of the following methods:

(1) Cut the new pipe to remove one of the re-rolled annular end sections required in Sections 943 or 945, or fabricate the pipe so that the re-rolled annular section is fabricated only on one end. Use either a spiral (helical) band with a gasket or a flat band with gaskets as required by 430-8.1.2 (2) to join the pipe sections.

(2) The Contractor may construct a concrete jacket as shown on the Design Standards, Index No. 280.

**430-8.1.2 Side Drain, Storm and Cross Drain, and Gutter Drains:** Where corrugated metal pipe is used as side drain, storm and cross drain, or gutter drain, use a rubber or neoprene gasket of a design shown to provide a joint as specified in 430-4.

Use a gasket of one of the following dimensions:

(1) For annular joints with 1/2 inch depth corrugation: either a single gasket a minimum of 7 inches by 3/8 inch or two gaskets a minimum of 3-1/2 inches by 3/8 inch; and for annular joints with 1 inch depth corrugations: either a single gasket a minimum of 7 inches by 7/8 inch or two gaskets a minimum of 3-1/2 inches by 7/8 inch.

(2) For helical joints with 1/2 inch depth corrugation: either a single gasket a minimum of 5 inches by 1 inch or two gaskets a minimum of 3-1/2 inches by 1 inch; and for helical joints with 1 inch depth corrugations: either a single gasket a minimum of 5 inches by 1-1/2 inches or two gaskets a minimum of 3-1/2 inches by 1-1/2 inches.

(3) Such other gasket designs as may be approved by the Engineer.

If, in lieu of a single gasket spanning the joint, two gaskets are used, place these individual gaskets approximately 2 inches from each pipe end at the joint. When two gaskets are used, seal the overlapping area on the coupling band between the gaskets consistent

with the joint performance specified. The Contractor may tuck a strip of preformed gasket material over the bottom lip of the band for this purpose. Use coupling bands that provide a minimum circumferential overlap of 3 inches. As the end connections on the coupling band are tightened, ensure that there is no local bending of the band or the connection. Use precurved coupling bands on pipe diameters of 24 inches or less.

Use flat gaskets meeting the requirements of ASTM D1056, designation 2C2 or 2B3. In placing flat gaskets on pipe prior to placing the coupling band, do not stretch the gasket more than 15% of its original circumference. Use circular gaskets meeting the requirements of ASTM C361. Do not stretch the circular gasket more than 20% of its original circumference in placing the gasket on pipe. Use preformed plastic gasket material meeting the composition requirements of 942-2.2.

Apply an approved vegetable soap lubricant, as specified for concrete pipe in 430-7.1.1.

**430-8.1.3 Alternate Joint:** In lieu of the above-specified combination of locking bands and flat gaskets, the Contractor may make field joints for these pipe installations by the following combinations:

(a) Use the metal bands as specified in Article 9 of AASHTO M36M that are at least 10-1/2 inches wide and consist of a flat central section with a corrugated section near each end, designed to match the annular corrugation in the pipe with which they are to be used. Connect the bands in a manner approved by the Engineer, with a suitable fastening device such as the use of two galvanized 1/2 inch diameter bolts through a galvanized bar and galvanized strap, suitably welded to the band. Use a strap that is the same gage as the band.

Where helically corrugated pipe is to be jointed by this alternate combination, ensure that at least the last two corrugations of each pipe section are annular, and designed such that the band will engage each pipe end with the next-to-outside annular corrugation.

(b) For these bands, use a rubber gasket with a circular cross-section of the “O-ring” type conforming to ASTM C361. Use gaskets having the following cross-sectional diameter for the given size of pipe:

Non-SI Units	
Pipe Size	Gasket Diameter
12 inches through 36 inches (with 1/2 inch depth corrugations)	13/16 inch
42 inches through 96 inches (with 1/2 inch depth corrugations)	7/8 inch
36 inches through 120 inches (with 1 inch depth corrugations)	1-3/8 inches

Use preformed gasket material to seal the overlapping area on the coupling band between gaskets.

(c) Use channel band couplers in helical pipe with ends which have been reformed and flanged specifically to receive these bands. Use channel band couplers that are of a two piece design, are fabricated from galvanized steel stock conforming to AASHTO M36, have 2 inch by 2 inch by 3/16 inch angles fastened to the band ends to allow for proper tightening, and meet the following:

Non SI Units	
Band Thickness	Pipe Wall Thickness
0.079 inch	0.109 inch or lighter
0.109 inch	0.138 inch or heavier
3/4 inch wide	0.109 inch or lighter
1 inch wide	0.138 inch or heavier

Furnish two 1/2 inch diameter connection bolts with each band, that conform to ASTM A307, Grade A and are electroplated in accordance with ASTM B633.

Use a gasket with the joint that is a hydrocarbon blend of butyl rubber meeting the chemical composition and physical properties of 942-2.2. Use a 3/8 by 3/4 inch gasket for pipe fabricated from 0.109 inch or lighter material and a 3/8 by 1 inch gasket for pipe fabricated from 0.138 inch and heavier material.

The Contractor may use a flange band coupler without the gasket for all applications other than side drain, storm and cross drain, and gutter drain.

Do not use the flange band coupler to join dissimilar types of pipe.

The Contractor may join reformed flanged helical pipe to existing annular or reformed pipe having annular ends. On non-gasketed installations, use either an annular band or an alternate joint described in 430-8.1.3. On gasketed installations, use an annular band, minimum of five corrugations in width, in conjunction with two O-ring gaskets as specified in 430-8.1.3. Use mastic material to seal the area of band overlap.

The minimum joint performance standards specified in 430-4.1 apply.

**430-8.2 Laying and Shape Requirements for Corrugated Metal Pipe:** Install pipe using either a trench or open ditch procedure.

Check pipe shape regularly during backfilling to verify acceptability of the construction method used. Pipe deflected 5% or more of the certified actual mean diameter of the pipe at final inspection shall be replaced at no cost to the Department. Deflection measurements are taken at the point of smallest diameter on the corrugations.

**430-9 Specific Requirements for Steel Reinforced Polyethylene Ribbed Pipe, Corrugated Polyethylene Pipe, Polypropylene Pipe, and Polyvinyl Chloride (PVC) Pipe.**

**430-9.1 Field Joints:** Use gasketed joints to seal side drain, and storm and cross drain. Use gaskets meeting the requirements of Section 449. Ensure that the pipe manufacturer provides a joint design approved by the Engineer before use.

**430-9.2 Installation Requirements Including Trenching, Foundation and Backfilling Operations:** Check structure shape regularly during backfilling to verify acceptability of the construction method used.

Replace pipe deflected 5% or more of the certified actual mean diameter of the pipe at final inspection at no cost to the Department.

**430-10 Desilting Pipe or Concrete Box Culvert.**

Desilt pipe culvert and concrete box culvert as designated in the Plans.

**430-11 Method of Measurement.**

**430-11.1 New Pipe Installed by Excavation or Trenching:** The quantity of storm and cross drain pipe, storm drain trench, side drain and gutter drain pipe, installed by pipe culvert

optional material - excavation or trenching, to be paid for will be plan quantity, in place and accepted. The plan quantity will be determined from the inside wall of the structure as shown in the Plans, along the centerline of the pipe.

Adjustment to bid quantities, prices and payment will not be allowed for increases, decreases or changes in material or installation requirements due to the use of any optional pipe materials.

If adjustments are required due to Plan errors or omissions or authorized field changes, the plotted material and not the material elected would be used to establish new pay quantities.

Pipe sizes other than round (elliptical/arch) are summarized and paid for using equivalent round pipe diameter.

**430-11.2 New Pipe Installed by Jack & Bore:** The quantity of storm and cross drain pipe, storm drain trench, side drain and gutter drain pipe, installed by pipe culvert optional material - jack & bore, to be paid for will be the plan quantity, in place and accepted. The measurement and payment will be the plan quantity length of the casing or carrier pipe installed by jack & bore.

Carrier pipe installed through/inside the casing is paid for as pipe culvert optional material – excavation or trenching.

**430-11.3 Mitered End Section:** The quantity of mitered end sections to be paid for will be the number completed and accepted.

#### **430-12 Basis of Payment.**

**430-12.1 General:** Prices and payments will be full compensation for all work specified in this Section, including all excavation except the volume included in the items for the grading work on the project, and except for other items specified for separate payment in Section 125; all backfilling material and compaction; disposal of surplus material; and all clearing and grubbing outside of the required limits of clearing and grubbing as shown in the Plans.

No payment will be made for failed bore paths, injection of excavatable flowable fill, products taken out of service, or incomplete installations. Payment will include all work and materials necessary for jack & bore, including boring, backfilling, flowable fill, and restoration materials necessary for a complete and accepted installation.

No payment will be made for jack & bore until a Bore Path Report has been delivered to the Engineer.

**430-12.2 Removing Existing Pipe:** When existing pipe is removed and replaced with new pipe approximately at the same location, the cost of excavating and removing the old pipe and of its disposal will be included in the Contract unit price for clearing and grubbing.

**430-12.3 Site Restoration:** The cost of restoring the site, as specified in 125-11, that is disturbed, solely for the purpose of constructing pipe culvert, will be included in the Contract unit price for the pipe culvert, unless designated specifically to be paid for under other items.

**430-12.4 Plugging Pipes:** The cost of temporarily plugging a pipe culvert, either proposed or existing, will be incidental to the contract unit price for new pipe culvert.

The cost of filling and/or plugging an existing pipe culvert that is to be permanently placed out of service will be paid for at the contract unit price for filling and plugging pipe, per cubic yard. Price and payment will be full compensation for flowable fill, masonry, concrete, mortar, and all labor and materials necessary to complete the work.

When the project includes no quantities for new pipe culverts, and temporary plugs are required for existing pipe culverts, the cost will be considered as extra work, in accordance with 4-3.5.

**430-12.5 Desilting Pipe:** Desilting pipe will be paid for at the contract unit price per foot for each pipe desilted. Price and payment will be full compensation for furnishing all equipment, tools and labor, disposal of silt and debris, and all incidentals necessary for satisfactorily performing the work.

**430-12.6 Desilting Concrete Box Culverts:** Price and payment will be full compensation for all work required.

**430-12.7 Flared End Sections:** Price and payment will be full compensation for all work and materials required.

**430-12.8 Mitered End Sections:** Price and payment will be full compensation for all pipe, grates when required, fasteners, reinforcing, connectors, anchors, concrete, sealants, jackets and coupling bands, and all work required.

**430-12.9 Railroad Requirements:** Where pipe culvert is constructed under railroad tracks, the Contract unit price for the pipe culvert will include the costs of any jacking operations and the operation of placing the pipe by use of a tunnel liner, (except as specified for unanticipated tunnel liner, in 430-6.5, where reimbursement is to be made for such unanticipated liner), and all other work necessary to meet the requirements of the railroad company, excluding the costs of watchman or flagman services provided by the railroad company, except as provided below.

The Department will reimburse the Contractor for the actual costs of any trestle bridge work which is performed by the railroad's forces, as billed to him by the railroad, less the value of any salvage materials derived there from, whether such salvage materials are retained by the railroad company or by the Contractor. When the work of shoring and bracing is to be performed by the railroad, such fact will be stipulated in the Contract Documents and the Contractor will be required to pay to the railroad the amount of such costs, which amount will be reimbursed to him by the Department. The Contract unit price for the pipe culvert shall include the costs of all other work of shoring and bracing.

**430-12.10 Payment Items:** Payment will be made under:

- Item No. 430- 17- Pipe Culvert Optional Material - Excavation or Trenching - per foot.
- Item No. 430- 18- Pipe Culvert Optional Material - Jack & Bore – per foot.
- Item No. 430- 94- Desilting Pipe – per foot.
- Item No. 430- 96- Polyvinyl Chloride Pipe - per foot.
- Item No. 430- 98- Mitered End Section - each.
- Item No. 430-200- Flared End Sections - each.
- Item No. 430-610- U-Endwall - each.
- Item No. 430-830- Filling and Plugging Pipe – cubic yard.
- Item No. 430-950- Desilting Concrete Box Culvert – per cubic yard.

**SECTION 449**  
**PRECAST CONCRETE DRAINAGE PRODUCTS**

**449-1 Description.**

Precast concrete drainage products hereinafter called products, may include but are not limited to, round concrete pipe, elliptical concrete pipe, underdrains, manholes, endwalls, inlets, junction boxes, three-sided precast concrete culverts, and precast concrete box culverts.

Ensure that all precast drainage products are designed and manufactured in accordance with the requirements of the Contract Documents.

Obtain precast concrete pipes, box culverts, and drainage structures from a plant that is currently on the Department's list of Producers with Accepted Quality Control Programs. Producers seeking inclusion on the list shall meet the requirements of 105-3.

At the beginning of each project, provide a notarized certification statement to the Engineer from a company designated representative certifying that the plant will manufacture the products in accordance with the requirements set forth in the Contract Documents and plant's Quality Control (QC) Plan. The Quality Control Manager's stamp on each product indicates certification that the product was fabricated in conformance with the Contractor's QC Plan, the Contract, and this Section. Ensure that each shipment of precast concrete products to the project site is accompanied with a QC signed or stamped delivery ticket providing the description and the list of the products.

When the producer's Quality Control Program is suspended by the Department, accept responsibility of either obtaining products from a plant with an approved Quality Control Program, or await re-approval of the plant. The Engineer will not allow changes in Contract time or completion dates as a result of the plant's loss of qualification. Accept responsibility for all delay costs or other costs associated with the loss of the plant's qualification.

**449-2 Materials.**

Ensure that the materials used for the construction of the precast drainage products have a certification statement from the source, showing that they meet the applicable requirements of the Specifications with the following modifications:



Reinforcing Bar.....	Section 415
Coarse Aggregate* .....	Section 901
Fine Aggregate* .....	Section 902
Portland Cement and blended cement.....	Section 921
Water .....	Section 923
Admixtures.....	Section 924
Pozzolans and slag .....	Section 929
Gasket Material.....	Section 942
Blended Hydraulic Cements .....	AASHTO M 240
Welded Wire Reinforcement .....	Section 931
Wire for Site Cage Machines.....	Section 931
Liner Repair Systems.....	Section 948

\*For concrete pipes the gradation requirements of concrete aggregates as set forth in Sections 901 and 902 are not applicable.

### 449-3 Construction Requirements.

Unless otherwise stipulated within the Contract Documents, meet the following requirements for concrete mix, product design, fabrication, transportation, and installation:

Three-Sided Precast Culverts .....	Section 407
Precast Concrete Box Culvert.....	Section 410
Pipe Culverts and Storm Sewers .....	Section 430
French Drains .....	Section 443
Inlets, Manholes, and Junction Boxes .....	Section 425
.....	and ASTM C 478
Underdrains .....	Section 440 and ASTM C 444
Steel Reinforced Round Concrete Pipe .....	ASTM C 76
Reinforced Elliptical Concrete Pipe .....	ASTM C 507
Non-reinforced Concrete Pipe .....	ASTM C 985

Meet the special requirements for the applicable pipes as described in 449-4 and 449-5.

### 449-4 Concrete Pipe.

**449-4.1 Special Requirements for Steel Reinforced Concrete Pipe:** Use pipe meeting the requirements of ASTM C76 with the modifications as described in 449-4.2. Use Special Designed pipe meeting the requirements of ASTM C655. Use Class S pipe meeting the requirements of ASTM C655. Ensure all pipes are properly marked.

**449-4.2 Modifications to ASTM C 76 and ASTM C 507:** The following supersedes the provisions of ASTM C76 and ASTM C507:

(a) Ensure all materials used in concrete are certified from the source and conform to the requirements of 449-2.

(b) Ensure all Joint Reinforcement requirements are in accordance with the Design Standards.

(c) When membrane curing compounds are used, ensure that the requirements of 925-2 are met and the membrane curing compounds are applied in accordance with 400-16 immediately after the pipe has been removed from the form.

(d) Ensure the manufacturer has a suitable apparatus for testing each product in accordance with ASTM C497 and performs all tests outlined in ASTM C497 when requested by the Engineer.

(e) Ensure that the variation of laying lengths of two opposite sides of pipe is not more than 1.04% of the diameter, with a maximum of 1/2 inch in any length of pipe, except where beveled-end pipe for laying on curves is specified.

(f) Ensure that the type of wall markings is included on all precast pipes.

(g) Ensure all repairs are made in accordance with Section 449-5.4.

**449-4.3 Special Requirements for Non-Reinforced Concrete Pipe:** Ensure the requirements of ASTM C985 are met with the following exception: Modify material requirements set forth in ASTM C985 with the material requirements set forth in 449-2. Ensure all pipes are properly marked.

**449-4.4 Special Requirements for Reinforced Elliptical Concrete Pipe:** Use elliptical concrete pipes conforming to the requirements of ASTM C507, except for the exceptions and modifications as specified in 449-4.2. Ensure the requirements of Table I of ASTM C507 for standard elliptical pipe, the requirements of Class HE-III and Class HE-IV of Table I of ASTM C507 for standard elliptical pipe and special elliptical pipe, respectively are met and the joint design requirements set forth in Article 7 of ASTM C443 are met.

**449-4.5 Concrete Underdrain Pipe:** Use perforated concrete pipe for underdrains meeting the requirements of ASTM C444, with the following modifications:

(a) Strength of finished pipe: Underdrain pipe will not be required to be reinforced, and will not be tested for strength of the finished pipe. Approval of the strength of the finished pipe will be based on visual inspection and check.

(b) Perforations: The perforations must be molded into the pipe at the time of fabrication, and any undue chips, fractures, incurred thereby, either in the interior of the pipe or on the periphery, which are sufficient to significantly impair the strength or efficiency, will be cause for rejection of the pipe.

Ensure the perforations are circular, and of the diameter called for below, with a tolerance of plus or minus 1/16 inch. Furnish all pipe included in any single order, or for any single installation operation, such diameter is reasonably uniform.

Schedule of Perforations For Concrete Underdrain Pipe				
Internal Diameter of Pipe	Diameter of Perforations *(Design)	Number of Rows	**Approximate distance between Rows	**Spacing within Rows
6 inches	3/8 inch	4	4 inches	5-6 inches
6 inches	1/4 inch	4	4 inches	4-5 inches
8 inches	3/8 inch	4	5 inches	5-6 inches
8 inches	1/4 inch	4	5 inches	4-5 inches

\*1/16 inch fabrication tolerance, over and under.  
 \*\*Perforations to be staggered in alternate rows. The spacing between rows must be uniform.

**449-4.6 Rejection of Concrete Pipe:** Specific causes for rejection of concrete pipe, in addition to any failure to meet the general requirements specified in the Contract Documents, are as follows:

(a) Failure to meet the requirements listed in ASTM C76 for permissible variations in dimensions with the modifications outlined in 449-4.1 and 449-4.2.

(b) Occurrence of defects listed in ASTM C76.

#### **449-5 Requirements For Pipe Joints When Rubber Gaskets Are To Be Used.**

**449-5.1 Design of Joint:** Use pipe joint of the bell-and-spigot type or the double spigot and sleeve type, meeting the requirements called for in the Design Standards. Ensure the joint is so proportioned that the spigot, or spigots, will readily enter the bell or sleeve of the pipe.

Ensure the joint ring forms for forming the joint surface are made of either heavy steel, cast iron, or aluminum, and accurately machined to the dimensions of the joint. They must be a true circular form within a tolerance of 1/32 inch. Dimensional checks of joint ring form will indicate for each size pipe a length of spigot, or tongue, not more than 1/8 inch shorter than the bell, or groove, depth. The pipe will be so manufactured that joint surfaces are concentric with the inside of the pipe within a tolerance of 3/32 inch. The shape and dimensions of the joint must be such as to provide compliance with the following requirements:

(a) The joint must be so dimensioned that when the gasket is placed on the spigot it will not be stretched more than 20% of its original length, or the maximum stretch length that is recommended by the manufacturer, whichever is lower.

(b) The space provided for the gasket must be a groove in the spigot end of the pipe and such space, when the joint is made, it cannot be more than 110% of the volume of the gasket.

(c) The joint must be designed so that when the outer surface of the spigot and the inner surface of the bell come into contact at some point on the periphery, the diametric deformation in the gasket at the point of contact cannot be greater than 50% of the normal gasket diameter, and the diametric deformation in the gasket at a point opposite the contact point cannot be less than 20% of the normal gasket diameter.

(d) When the pipes are joined, there must be parallel surfaces on both the bell and the spigot, extending from the outside edge of the gasket toward the bell face for a distance of not less than 3/4 inch. These parallel surfaces cannot be farther apart than 1/8 inch, when the spigot is centered in the bell. The tapers on these surfaces cannot exceed three degrees.

(e) The inside surface of the bell at the end of the bell must be flared to facilitate joining the pipe sections without damaging or displacing the gasket.

**449-5.2 When Rubber Gaskets are Used:** Ensure that the pipe joints have been tested at the plant hydrostatically and shown to meet the requirements of Section 6.2 of the Materials Manual, which is available at the following URL:

<http://www.dot.state.fl.us/specificationsoffice/Implemented/URLinSpecs/files/section62.pdf> .

**449-5.3 When Profile Rubber Gaskets are Used:** Ensure the joint design meets the requirements set forth in Article 7 of ASTM C443.

**449-5.4 Tolerances in Imperfections, and Permissible Repairs for Joint of Concrete Gasketed Pipe:** Ensure that all surfaces of near-contact of the jointed pipes are free from air holes, chipped or spalled concrete, laitance, and other such defects.

Pipes showing minor manufacturing imperfections or handling injuries to the bell or spigot may be acceptable if such defects are acceptably repaired as prescribed below.

Individual air holes (trapped air), or spalled areas with a length of up to one-half the pipe radius, or 12 inches whichever is less, may be repaired by careful use of a hand-placed, stiff, pre-shrunk, 1-to-1 mortar of cement and fine sand, and with no additional preparation other than a thorough washing with water of the defect. Curing will be done either by moisture curing under wet burlap or by application of an approved membrane curing compound. Such repaired pipe which is sound, properly finished and cured, and which otherwise conforms to specification requirements will be acceptable.

Exposed reinforcing and minor spalling in the spigot groove may be accepted if repaired in the following manner: The spalled areas will be chipped back to solid concrete. Exposed reinforcing will be cleaned of all laitance and scale. The entire area is to be coated with an approved epoxy at a thickness of 5 to 10 mils. The coating must be smooth and conform to the shape of the groove. The epoxy must be a Type F-1 as specified in Section 926.

**SECTION 570**  
**PERFORMANCE TURF**

**570-1 Description.**

Establish a growing, healthy turf over all areas designated in the Plans. Use sod in areas designated in the Plans to be sodded. Use seed, hydroseed, bonded fiber matrix, or sod in all other areas. Maintain turf areas until final acceptance of all contract work in accordance with Section 5-11.

**570-2 Materials.**

Meet the following requirements:

Turf Materials .....	Section 981
Fertilizer .....	Section 982
Water .....	Section 983

**570-3 Construction Methods.**

**570-3.1 General:** Incorporate turf installation into the project at the earliest practical time.

Shape the areas to be planted to the plan typical sections and lines and grade shown in the Contract Documents.

Except in areas where the Contract Documents requires specific types of grass to match adjoining private property, any species of grass designated in Section 981 may be used. Use the methods and materials necessary to establish and maintain the initial grassing until acceptance of the Contract work in accordance with 5-11. All of the permanent grassing material shall be in place prior to final acceptance.

The Department will only pay for replanting as necessary due to factors determined by the Engineer to be beyond control of the Contractor.

Complete all grassing on shoulder areas prior to the placement of the friction course on adjacent pavement.

**570-3.2 Seeding:** At the Contractor's option, wildflower seed may be included in the turf seeding operation or performed separately from the turf seeding.

Use of compost meeting the requirements of Section 987 as mulch is acceptable unless otherwise specified.

**570-3.3 Sod:** Place the sod on the prepared surface, with edges in close contact. Do not use sod which has been cut for more than 48 hours.

Place the sod to the edge of all landscape areas as shown in the Plans and as shown in the Design Standards.

Place rolled sod parallel with the roadway and cut any exposed netting even with the sod edge.

Monitor placed sod for growth of pest plants and noxious weeds. If pest plants and/or noxious weeds manifest themselves within 30 days of placement of the sod during the months April through October, within 60 days of placement of the sod during the months of November through March treat affected areas by means acceptable to the Department at no expense to the Department. If pest plants and/or noxious weeds manifest themselves after the time frames described above from date of placement of sod, the Engineer, at his sole option, will determine if treatment is required and whether or not the Contractor will be compensated for

such treatment. If compensation is provided, payment will be made as Unforeseeable Work as described in 4-4.

Remove and replace any sod as directed by the Engineer.

**570-3.4 Hydroseeding:** Use equipment specifically designed for mixing the mulch, seed, fertilizer, tackifier and dye, and applying the slurry uniformly over the areas to be hydroseeded.

Use mulch that does not contain reprocessed wood or paper fibers. Ensure that 50% of the fibers will be retained on a twenty-five mesh screen.

Mix fertilizer as required into the hydroseeding slurry.

Ensure that the dye does not contain growth or germination inhibiting chemicals.

When polyacrylamide is used as part of hydroseeding mix, only anionic polymer formulation with free acrylamide monomer residual content of less than 0.05% is allowed. Cationic polyacrylamide shall not be used in any concentration. Do not spray polyacrylamide containing mixtures onto pavement. These may include tackifiers, flocculants or moisture-holding compounds.

**570-3.5 Bonded Fiber Matrix (BFM):** Meet the minimum physical and performance criteria of this Specification for use of BFM in hydroseeding operations or temporary non-vegetative erosion and sediment control methods.

Provide evidence of product performance testing, manufacturer's certification of training and material samples to the Engineer at least 7 calendar days prior to installation.

Provide documentation to the Engineer of manufacturer's testing at an independent laboratory, demonstrating superior performance of BFM as measured by reduced water runoff, reduced soil loss and faster seed germination in comparison to erosion control blankets.

Use only BFMs that contain all components pre-packaged by the manufacturer to assure material performance. Deliver materials in UV and weather resistant factory labeled packaging. Store and handle products in strict compliance with the manufacturer's directions.

When polyacrylamide is used as part of hydroseeding mix, only anionic polymer formulation with free acrylamide monomer residual content of less than 0.05% is allowed. Cationic polyacrylamide shall not be used in any concentration. Do not spray polyacrylamide containing mixtures onto pavement. These may include tackifiers, flocculants or moisture-holding compounds.

Meet the following requirements after application of the formed matrix:

Ensure that the tackifier does not dissolve or disperse upon re-wetting.

Ensure that the matrix has no gaps between the product and the soil and that it provides 100% coverage of all disturbed soil areas after application.

Ensure that the matrix has no germination or growth inhibiting properties and does not form a water-repelling crust.

Ensure that the matrix is comprised of materials which are 100% biodegradable and 100% beneficial to plant growth.

Mix and apply the BFM in strict compliance with the manufacturer's recommendations.

Apply the BFM to geotechnically stable slopes at the manufacturer's recommended rates.

Degradation of BFM will occur naturally as a result of chemical and biological hydrolysis, UV exposure and temperature fluctuations. Re-application, as determined by the Engineer, will be required if BFM-treated soils are disturbed or water quality or turbidity tests

show the need for an additional application. The work and materials for re-application, will be paid for as Unforeseeable Work.

**570-3.6 Watering:** Water all turf areas as necessary to produce a healthy and vigorous stand of turf. Ensure that the water used for turf irrigation meets the requirements of Section 983.

**570-3.7 Fertilizing:** Fertilize as necessary based on soil testing performed in accordance with Section 162. Refer to Section 982 for fertilizer rates.

For bid purposes, base estimated quantities on an initial application of 265 lbs/acre and one subsequent application of 135 lbs/acre of 16-0-8.

#### **570-4 Turf Establishment.**

Perform all work necessary, including watering and fertilizing, to sustain an established turf until final acceptance, at no additional expense to the Department. Provide the filling, leveling, and repairing of any washed or eroded areas, as may be necessary.

Established turf is defined as follows:

1. An established root system (leaf blades break before seedlings or sod can be pulled from the soil by hand).
2. No bare spots larger than one square foot.
3. No continuous streaks running perpendicular to the face of the slope.
4. No bare areas comprising more than 1% of any given 1,000 square foot area.
5. No deformation of the turf areas caused by mowing or other Contractor equipment.
6. No exposed sod netting.
7. No pests or noxious weeds.

Monitor turf areas and remove all competing vegetation, pest plants, and noxious weeds (as listed by the Florida Exotic Pest Plant Council, Category I “List of Invasive Species”, Current Edition, <http://www.fleppc.org>). Remove such vegetation regularly by manual, mechanical, or chemical control means, as necessary. When selecting herbicides, pay particular attention to ensure use of chemicals that will not harm desired turf or wildflower species. Use herbicides in accordance with 7-1.7.

If at the time that all other work on the project is completed, but all turf areas have not met the requirements for established turf set forth in 570-4, continuously maintain all turf areas until the requirements for established turf set forth in 570-4 have been met.

During the entire establishment period and until turf is established in accordance with this specification, continue inspection and maintenance of erosion and sedimentation control items in accordance with Section 104. Take responsibility for the proper removal and disposal of all erosion and sedimentation control items after turf has been established.

Notify the Engineer, with a minimum of seven calendar days advance notice, to conduct inspections of the turf at approximate 90-day intervals during the establishment period to determine establishment. Results of such inspections will be made available to the Contractor within seven calendar days of the date of inspection. Determination of an established turf will be based on the entire project and not in sections.

Upon the determination by the Engineer that the requirements of 570-4 have been met and an established turf has been achieved and all erosion and sedimentation control items have been removed, the Engineer will release the Contractor from any further responsibility provided for in this Specification.

The Contractor's establishment obligations of this specification will not apply to deficiencies due to the following factors, if found by the Engineer to be beyond the control of the Contractor, his subcontractors, vendors or suppliers:

a. Determination that the deficiency was due to the failure of other features of the Contract.

b. Determination that the deficiency was the responsibility of a third party performing work not included in the Contract or its actions.

The Department will only pay for replanting as necessary due to factors determined by the Department to be beyond the control of the Contractor.

**570-5 Responsible Party.**

For the purposes of this Specification, the Contractor shall be the responsible party throughout construction and establishment periods.

Upon final acceptance of the Contract in accordance with 5-11, the Contractor's responsibility for maintenance of all the work or facilities within the project limits of the Contract will terminate in accordance with 5-11; with the sole exception that the facilities damaged due to lack of established turf and the obligations set forth in this Specification-for performance turf shall continue thereafter to be responsibility of the Contractor as otherwise provided in this Section.

**570-6 Disputes Resolution.**

The Contractor and the Department acknowledge that use of the Statewide Disputes Review Board is required and the determinations of the Statewide Disputes Review Board for disputes arising out of the performance turf specification will be binding on both the Contractor and the Department, with no right of appeal by either party, for the purposes of this Specification.

Any and all Statewide Disputes Review Board meetings after final acceptance of the Contract in accordance with 5-11 shall be requested and paid for by the Contractor. The Department will reimburse the Contractor for all fees associated with meetings.

**570-7 Failure to Perform.**

Should the Contractor fail to timely submit any dispute to the Statewide Disputes Review Board, refuse to submit any dispute to the Statewide Disputes Review Board, fail to provide an established turf in accordance with 570-4 within one year of final acceptance of the Contract in accordance with 5-11, or fail to compensate the Department for any remedial work performed by the Department in establishing a turf and other remedial work associated with lack of an established turf, including but not limited to, repair of shoulder or other areas due to erosion and removal of sediments deposited in roadside ditches and streams, as determined by the Statewide Disputes Review Board to be the Contractor's responsibility, the Department shall suspend, revoke or deny the Contractor's certificate of qualification under the terms of Section 337.16(d)(2), Florida Statutes, until the Contractor provides an established turf or makes full and complete payment for the remedial work performed by the Department. In no case shall the period of suspension, revocation, or denial of the Contractor's certificate of qualification be less than six months. Should the Contractor choose to challenge the Department's notification of intent for suspension, revocation or denial of qualification and the Department's action is upheld, the Contractor shall have its qualification suspended for a minimum of six months or until the remedial action is satisfactorily performed, whichever is longer.



**570-8 Method of Measurement.**

The quantities to be paid for will be plan quantity in square yards based on the area shown in the Plans, completed and accepted.

**570-9 Basis of Payment.**

Prices and payments will be full compensation for all work and materials specified in this Section.

Payment will be made under:

Item No. 570- 1- Performance Turf - per square yard.

**SECTION 948  
OPTIONAL DRAINAGE PRODUCTS AND  
LINER REPAIR SYSTEMS**

~~948-1 Polyvinyl-Chloride (PVC) Pipe, or Acrylonitrile-Butadiene-Styrene (ABS) Plastics~~

**Pipe.** This material is not approved for use in the District

ASTM  
classific  
for UV protection.

pipe shall conform to the requirements of  
ile 80 PVC pipe with a minimum polymer cell  
and a minimum of 1.5% by weight of titanium dioxide

~~948-1.2 Pressure Pipe:~~ Pressure pipe for direct burial under pavement shall conform to the requirements of ASTM D1785, for Type I, Grade I, Schedule 40, for sizes up to and including 2-1/2 inches, and Schedule 80 for sizes up to 4 inches. Pressure pipe 4 inches in diameter and larger shall conform to the requirements of AWWA C900-75, DR18, and ASTM D1785, Type I, Grade I or other types as may be specifically called for in the Plans or Special Provisions.

~~948-1.3 Pipe Marking:~~ All PVC pipe shall be marked as required by Article 8 of ASTM D1785, and acceptance of the pipe may be based on this data.

~~948-1.4 Nonpressure Pipe:~~ PVC pipe and ABS pipe intended for direct-burial or concrete encasement, shall meet the following requirements:

(a) PVC Pipe: ASTM D3034, SDR-35, or ASTM F949, profile wall without perforations.

(b) ABS Pipe: ASTM D2680.

The manufacturer of the PVC or ABS pipe shall furnish to the Engineer six copies of mill analysis covering chemical and physical test results.

~~948-1.5 Underdrain:~~ PVC pipe for use as underdrain shall conform to the requirements of ASTM F758 or ASTM F949. Also, PVC underdrain manufactured from PVC pipe meeting ASTM D3034, perforated in accordance with the perforation requirements given in AASHTO M36 or AASHTO M196 will be permitted.

~~948-1.6 Edgedrain:~~ PVC pipe for use as edgedrain shall conform to the requirements of ASTM F758, ASTM F949 or ASTM D3034 pipe shall be perforated in accordance with the perforation requirements given in AASHTO M36 or AASHTO M196. Additional perforations will be required as indicated in the Design Standards, Index No. 286 for pipes designated under ASTM F758 and ASTM D3034. PVC pipe intended for direct burial in asphalt shall meet the following requirements:

(a) ASTM D3034, SDR-35, or ASTM F949

(b) NEMA TC-2 (pipe material and compounds) and NEMA TC-3 (pipe fittings) for PVC (90°C electrical conduit pipe) NEMA ECP-40 and NEMA ECP-80. Underwriter Laboratory Specifications referenced under NEMA specifications for electrical conductivity are not required.

(c) Pipe shall withstand asphalt placement temperatures specified without permanent deformation.

(d) Perforations shall be in accordance with AASHTO M36 or AASHTO M196.

~~948-1.7 PVC Pipe (12 Inches to 48 Inches):~~ PVC pipe for side drain, cross drain, storm drain and other specified applications shall conform to AASHTO M278 for smooth wall PVC

pipe or ASTM F949 for PVC ribbed pipe. Resin shall contain a minimum of 1.5% by weight of titanium dioxide for UV protection. Mitered end sections are not to be constructed of PVC.

PVC pipe shall be installed within two years from the date of manufacture.

All pipe produced and shipped to the job site shall meet the requirements of 105-

3.2.

**948-2 Corrugated Polyethylene Tubing and Pipe.**

**948-2.1 General:** For underdrain, corrugated polyethylene tubing and fittings shall meet the requirements of AASHTO M252. For edgedrain, corrugated polyethylene tubing and fittings shall meet the requirements of AASHTO M252, except as modified in 948-2.2. For storm drain side drain, french drain and cross drain corrugated polyethylene pipe shall meet the requirements of AASHTO M-294 and 948-2.3.

The tubing or pipe shall not be left exposed to sunlight for periods exceeding the manufacturer’s recommendation.

**948-2.2 Edgedrain (4 Inches to 10 Inches):** The requirements for edgedrain as specified in AASHTO Mp-252 are modified as follows:

(a) Coiling of tubing 6 inches in diameter or greater is not permitted. Tubing shall have a minimum pipe stiffness of 46 psi at 5% deflection.

**948-2.3 Corrugated High Density Polyethylene Pipe (HDPE) (12 Inches to 60 Inches):**

~~948-2.3.1 General:~~ Class I (50 year) corrugated polyethylene pipe used for side drain, storm and cross drain or french drain shall meet the requirements of AASHTO M294 and plant certification from the National Transportation Product Evaluation Program (NTPEP). Corrugations shall be annual classification 435400C and constructed of polyethylene.

HDPE Pipe installed within the District shall meet these requirements.

All pipe produced and shipped to the job site shall meet the requirements of 105-3.2.

**948-2.3.2 Additional Requirements for Class II HDPE (100 Year), Type S**

**Polyethylene Pipe:** Class II HDPE (100 year) polyethylene pipe shall meet the requirements in Table 948-1 below in addition to those in 948-2.3. Perforations will not be allowed. Manufacturers may only use ground Class II polyethylene pipe for reworked plastic.

Table 948-1			
Stress Crack Resistance of Pipes			
Pipe Location	Test Method	Test Conditions	Requirement
Pipe Liner	FM 5-572, Procedure A	10% Igepal solution at 122°F and 600 psi applied stress, 5 replicates	Average failure time of the pipe liner shall be $\geq 18.0$ hours, no single value shall be less than 13.0 hours.
Pipe Corrugation <sup>(1)</sup> , (molded plaque)	ASTM F2136	10% Igepal solution at 122°F and 600 psi applied stress, 5 replicates	Average failure time shall be $\geq 24.0$ hours, no single value shall be less than 17.0 hours.

Table 948-1			
Junction	FM 5-572, Procedure B and FM 5-573	Full Test <sup>(2)(3)</sup> Test at 3 temperature/stress combinations: 176°F at 650 psi 176°F at 450 psi 158°F at 650 psi; 5 replicates at each test condition	Determine failure time at 500 psi at 73.4°F ≥ 100 years (95% lower confidence) using 15 failure time values <sup>(4)</sup> The tests for each condition can be terminated at duration equal to or greater than the following criteria: 110.0 hr at 176°F 650 psi 430.0 hr at 176°F 450 psi 500.0 hr at 158°F 650 psi
		Single Test <sup>(5)</sup> : Test temperature 176°F and applied stress of 650 psi.; 5 replicates	The average failure time must be equal to or greater than 110.0 hr
Longitudinal Profiles <sup>(6)</sup>	FM 5-572, Procedure C, and FM 5-573	Full Test <sup>(2)(3)</sup> : Test at 3 temperature/stress combinations: 176°F at 650 psi 176°F at 450 psi 158°F at 650 psi; 5 replicates at each test condition	Determine failure time at 500psi at 73.4°F ≥ 100 years (95% lower confidence) using 15 failure time values <sup>(4)</sup> . The tests for each condition can be terminated at duration equal to or greater than the following criteria: 110.0 hr at 176°F 650 psi 430.0 hr at 176°F 450 psi 500.0 hr at 158°F 650 psi
		Single Test <sup>(5)</sup> : Test temperature 176°F and applied stress of 650 psi.; 5 replicates	The average failure time must be equal to or greater than 110.0 hr (no value shall be less than 55.0 hours)
Oxidation Resistance of Pipes			
Pipe Location	Test Method	Test Conditions	Requirement
Liner and/or Crown <sup>(7)</sup>	OIT Test (ASTM D3895)	2 replicates (to determine initial OIT value) on the as manufactured (not incubated) pipe.	25.0 minutes, minimum
Liner and/or Crown <sup>(7)</sup>	Incubation test FM 5-574 and OIT test (ASTM D3895)	Three samples for incubation of 265 days at 176°F <sup>(8)</sup> and applied stress of 250 psi. One OIT test per each sample	Average of 3.0 minutes <sup>(9)</sup> (no values shall be less than 2.0 minutes)
Liner and/or Crown <sup>(7)</sup>	MI test (ASTM D1238 at 190°C/2.16Kg)	2 replicates on the as manufactured (not incubated) pipe.	< 0.4 g/10 minutes

Table 948-1			
Liner and/or Crown <sup>(7)</sup>	Incubation test FM 5-574 and MI test (ASTM D1238 at 190°C/2.16Kg)	2 replicates on the three aged sampled after incubation of 265 days at 176°F <sup>(8)</sup> and applied stress of 250 psi	MI Retained Value <sup>(9)(10)</sup> shall be greater than 80% and less than 120%.

Note: FM = Florida Method of Test.

(1) Required only when the resin used in the corrugation is different than that of the liner.

(2) A higher test temperature (194°F) may be used if supporting test data acceptable to the State Materials Engineer is submitted and approved in writing.

(3) Full test shall be performed on alternative pipe diameter of pipe based on wall profile design, raw material cell classification, and manufacturing process. Full test must be performed on maximum and minimum pipe diameters within a manufacturing process.

(4) Computer program to predict the 100 year SCR with 95% lower confidence can be obtained from FDOT.

(5) Single test for the junction and longitudinal profile may be used on alternating pipe sizes within a manufacturing process. Single point tests may not be used on maximum and minimum pipe sizes within a manufacturing process except by approval of the Engineer. Single point tests may be used for quality assurance testing purposes.

(6) Longitudinal profiles include vent holes and molded lines.

(7) OIT and MI tests on the crown are required when resin used in the corrugation is different than that of the liner.

(8) The incubation temperature and duration can also be 196 days at 185°F.

(9) The tests for incubated and “as-manufactured” pipe samples shall be performed by the same lab, same operator, the same testing device, and in the same day.

(10) The MI retained value is determined using the average MI value of incubated sample divided by the average MI value of as-manufactured pipe sample.

**948-2.3.3 Certification:** Furnish to the Engineer signed certification from the manufacturer for each pipe diameter LOT to be incorporated into the project that the pipe meets the requirements of these Specifications.

**948-2.3.4 Laboratory Accreditation:** Manufacturers seeking evaluation of a product in accordance with Departmental procedures must submit test reports conducted by a laboratory qualified by the Geosynthetic Accreditation Institute-Laboratory Accreditation Program (GAI-LAP) or qualified by ISO 17025 accreditation agency using personnel with actual experience running the test methods for Class II HDPE pipe. Submit the test reports to the State Materials Office.

~~**948-2.4 Steel Reinforced Polyethylene Ribbed Pipe:**~~

**948-2.4.1 General:** Steel reinforced polyethylene ribbed pipe used for side drain, storm and cross drain or french drain shall meet the requirements of AASHTO MP20-13 or ASTM F-2562 and the testing requirements for stress crack and oxidation resistance in Table 1. Pipe resin shall conform to ASTM D3350 with a minimum cell classification 435400C and between 2% to 4% carbon black. Mitered end sections are not to be constructed of steel reinforced polyethylene ribbed pipe.

All pipe produced and shipped to the job site shall meet the requirements of 105-3.2.

**948-2.4.2 Certification:** Meet the requirements of 948-2.3.3.

**948-2.4.3 Laboratory Accreditation:** Meet the requirements of 948-2.3.4 except use personnel with actual experience running the test methods for steel reinforced polyethylene ribbed pipe.

~~**948-3 Fiberglass Reinforced Polymer Pipe:**~~

**948-3.1 For Bridge Drains:** Fiberglass pipe shall conform to the requirements of ASTM D3262, ASTM D2996 or ASTM D2310, for Type I, Grade 2, Class E, using polyvinyl

ester as the only resin. The minimum hoop stress designation shall be A. The resin shall contain UV stabilizers or a two-part 100% solids polyurethane coating.

~~948-4 Ductile Iron Pipe.~~

**948-4.1 For Bridge Drains:** Ductile iron pipe shall conform to the requirements of AWWA C151.

~~948-5 Hot Dip Galvanized Steel Pipe.~~

**948-5.1 For Bridge Drains:** Hot dip galvanized steel pipe shall conform to the requirements of ASTM A53.

~~948-6 Flexible Transition Couplings and Pipe~~

**948-6.1 For Bridge Drains:** Flexible transition couplers and pipe shall conform to the requirements of ASTM C1173.

~~948-7 Profile Wall Polypropylene (PP) Pipe (12 Inches to 60 Inches).~~

**948-7.1 Class I PP:** Class I (50 year) PP pipe used for side drain, cross drain, storm drain, and french drain shall meet the requirements of AASHTO M330 and plant certification from the NTPEP. Corrugations shall be annular. Polypropylene compound shall conform to the requirements of ASTM F2881. Mitered end sections are not to be constructed of polypropylene.

All pipe produced and shipped to the job site shall meet the requirements of 105-3.2.

**948-7.2 Additional Requirements for Class II (100 Year) PP:** Class II (100 year) PP shall meet the requirements in Table 948-2 in addition to those in 948-7.1. Manufacturers may only use ground Class II PP for reworked plastic.

Table 948-2			
Stress Crack Resistance			
Pipe Location	Test Method	Test Conditions	Requirement
Pipe Liner	FM 5-572, Procedure A	10% Igepal solution at 50°C and 600 psi applied stress, 5 replicates	Average failure time of the pipe liner shall be $\geq 100$ hours, no single value shall be less than 71 hours. <sup>(1)</sup>
Oxidation Resistance			
Pipe Location	Test Method	Test Conditions	Requirement
Pipe Liner and/or Crown <sup>(2)</sup>	OIT Test (ASTM D3895)	2 replicates (to determine initial OIT value) on the as manufactured (not incubated) pipe.	25.0 minutes, minimum
Pipe Liner and/or Crown <sup>(2)</sup>	Incubation test FM 5-574 and OIT test (ASTM D3895)	Three samples for incubation of 264 days at 85°C <sup>(3)</sup> . One OIT test per each sample	Average of 3.0 minutes <sup>(4)</sup> (no values shall be less than 2.0 minutes)
Pipe Liner and/or Crown <sup>(2)</sup>	MI test (ASTM D1238 at 230°C/2.16Kg)	2 replicates on the as manufactured (not incubated) pipe.	< 1.5 g/10 minutes

Table 948-2			
Pipe Liner and/or Crown <sup>(2)</sup>	Incubation test FM 5-574 and MI test (ASTM D1238 at 230°C/2.16Kg)	2 replicates on the three aged sampled after incubation of 264 days at 85°C <sup>(3)</sup>	MI Retained Value <sup>(4)(5)(6)</sup> shall be greater than 80% and less than 120%.
<p>Note: FM = Florida Method of Test.</p> <p>(1) If due to sample size this test cannot be completed on the liner then testing shall be conducted on a molded plaque sample. Samples can be removed if test time exceeds 100 hours without failure.</p> <p>(2) OIT and MI tests on the crown are required when resin used in the corrugation is different than that of the liner.</p> <p>(3) The incubation temperature and duration can also be 192 days at 90°C or 140 days at 95°C.</p> <p>(4) The tests for incubated and “as-manufactured” pipe samples shall be performed by the same lab, same operator, the same testing device, and in the same day.</p> <p>(5) Within each replicate set of tests, the discrepancy range shall be within 9%. If an out-of-range discrepancy occurs, repeat the two MI tests on the same pipe sample. If insufficient material is available, a repeat of one test is acceptable.</p> <p>(6) The MI retained value is determined using the average MI value of incubated sample divided by the average MI value of as-manufactured pipe sample.</p>			

**948-7-2 Certification:** Meet the requirements of 948-2.3.3.

**948-7.4 Laboratory Accreditation:** Meet the requirements of 948-2.3.4 except use personnel with actual experience running the test methods for profile wall polypropylene pipe.

~~**948-8 Filter Fabric Sock for Use with Underdrain**~~

For Type I underdrain specified in the Design Standards, Index No. 286, filter sock shall be an approved strong rough porous, polyester or other approved knitted fabric which completely covers and is secured to the perforated plastic tubing underdrain in such a way as to prevent infiltration of trench backfill material.

The knitted fabric sock shall be a continuous one piece material that fits over the tubing like a sleeve. It shall be knitted of continuous 150 denier yarn and shall be free from any chemical treatment or coating that might significantly reduce porosity and permeability.

The knitted fabric sock shall comply with the following physical properties:

Weight, applied (oz/sq. yd.)	3.5 min	ASTM D3887
Grab tensile strength (lbs.)	50 min.*	ASTM D5034
Equivalent opening size (EOS No.)	25 min.**	Corps of Engineers CW-02215-77
Burst strength (psi)	100 min.**	ASTM D3887

\*Tested wet.

\*\*Manufacturer's certification to meet test requirement.

The knitted fabric sock shall be applied to the tubing in the shop so as to maintain a uniform applied weight. The tubing with knitted fabric sock shall be delivered to the job site in such manner as to facilitate handling and incorporation into the work without damage. The knitted fabric sock shall be stored in UV resistant bags until just prior to installation. Torn or punctured knitted fabric sock shall not be used.

~~**948-9 Liner Repair Systems for Rehabilitation of Pipe and Other Drainage Structures.**~~

**948-9.1 General:** Liner systems shall have at least the minimum stiffness required for the intended application in accordance with the AASHTO LRFD Bridge Design Specifications.

**948-9.2 Folded Liner:** Folded liner shall be manufactured in an out of form state, usually collapsed circumferentially, and folded on the long axis. After installation in a host structure, the liner is formed by means of heat and pressure to fit the host structure. When installed, folded liner shall extend from one structure to the next in one continuous length with no intermediate joints.

**948-9.2.1 Polyethylene:** Folded polyethylene liner shall meet the requirements of ASTM 2718 or ASTM F714 with a minimum cell classification of 335420 and between 2% to 4% carbon black.

**948-9.2.2 PVC:** Folded PVC liner shall meet the requirements of ASTM F1504 (meet all the requirements for cell classification 12334 or 13223) or ASTM F1871 (meet all the requirements for cell classification 12111).

**948-9.2.3 Cured-In-Place:** Folded resin impregnated flexible tubing shall meet the requirements of ASTM F1216 and ASTM D5813.

**948-9.3 Prefabricated (Slip) Pipe Liner:** When used in slip lining applications, prefabricated liner shall be round, flexible or semi-rigid liner, manufactured in lengths that may be joined in a manhole or access pit before insertion in a host pipe.

**948-9.3.1 Polyethylene:**

(a) Solid wall polyethylene pipe liner shall meet the requirements of ASTM F714 or AASHTO M326 and shall have a minimum cell classification of 345464 and between 2% to 4% carbon black.

(b) Profile wall polyethylene pipe liner shall meet the requirements of AASHTO M294 and shall have a minimum cell classification of 435400 and between 2% to 4% carbon black

(c) Steel reinforced polyethylene pipe liner shall meet the requirements of AASHTO MP20-13, ASTM F2562 or ASTM F2435 and shall have a minimum cell classification of 334452 and between 2% to 4% carbon black.

**948-9.3.2 PVC:**

(a) Solid wall PVC pipe liner shall meet the requirements of ASTM D2729 and shall have a minimum cell classification of 12454.

(b) Profile wall PVC pipe liner shall meet the requirements of ASTM F794, ASTM F949, or AASHTO M304 and shall have a minimum cell classification of 12454.

**948-9.3.3 Fiberglass:** Prefabricated fiberglass pipe liner shall meet the requirements of ASTM D3262.

**948-9.4 Spiral-Wound Liner:** Spiral-wound liner shall consist of coils of profile strips or one piece profile strips that are wound directly into a host pipe helically

**948-9.4.1 Polyethylene:** Polyethylene spiral-wound liner shall meet the requirements of ASTM F1697 or ASTM F1735, except the resin shall conform to ASTM D3350 with a minimum cell classification of 335420 and between 2% to 4% carbon black.

**948-9.4.2 PVC:** PVC spiral-wound liner shall meet the requirements of ASTM F1697 or ASTM F1735 and shall have a minimum cell classification of 12454.

**948-9.4.3 Steel Reinforced:** Steel reinforced spiral-wound liner shall meet the requirements of ASTM F1697 or ASTM F1735, except the resin shall conform to ASTM D3350



with a minimum cell classification of 335420 and between 2% to 4% carbon black. The steel reinforcement shall be fully encapsulated to prevent exposure to corrosive elements.

**948-9.5 Segmental Panel Liner:** Segmental panel liner consists of custom fit flat or curved panels that are formed to the inside wall of a host structure.

**948-9.5.1 Polyethylene:** Polyethylene segmental panel liner shall meet the requirements of ASTM F1735, except the resin shall conform to ASTM D3350 with a minimum cell classification of 345464 and between 2% to 4% carbon black.

**948-9.5.2 PVC:** PVC segmental panel liner shall meet the requirements of ASTM F1735 and shall have a minimum cell classification of 12454.

**948-9.6 Point Repair Liner:** Point repair liner may be used to repair and rehabilitate an isolated portion of an existing structure and may consist of any materials covered by this specification. Materials that shall be used as primary components of point repair apparatus are:

(1) Stainless steel, which shall meet the requirements of AASHTO M167M, ASTM A167, or ASTM A240

(2) Aluminum, which shall meet the requirements of AASHTO M196

(3) Rubber, which shall meet the requirements of ASTM C923.

**948-9.7 Coating Liner:** Coating liners consist of liquid, slurry, foam or gel that is spread or sprayed over the interior surface of an existing structure to rehabilitate it, with or without fiber reinforcement. Coating liner installers shall submit to the Department proof of experience for on-site supervision and previously completed contracts including the following:

(1) Project name and location

(2) Names of contracting parties

(3) Owner's names

(4) A brief description of the work

(5) Dates of completion of coating liner work

Materials that may be used for coating are:

(1) Hydrophilic urethane-based foams or gels which shall meet the requirements of ASTM F2414.

(2) Epoxy resins and unsaturated styrene-based resins which shall meet the resin material requirements of ASTM F1216.

(3) Cementitious materials, as recommended by the manufacturer, including:

(a) annular backfill

(b) low density cellular concrete

(c) shotcrete

(d) gunite

(e) centrifugal cast

(f) pre-packaged grout

APPENDIX E  
SPILL REPORTING PROCEDURES

### Procedure when responding to a spill ONLY on the roadway

1. Call DOT Operations at 533-9400 to report the spill. DOT will then send someone from their first responders list to assess the spill.
2. If the persons responsible for the spill are on location, the responder will supply them with a list of contractors in which they can hire for accident clean up.
3. The responder will then stay on site until the contractor arrives.
4. At this point he/ she will gather as much info as possible regarding the truck and company involved, as well as handling the MOT until the contractor arrives.
5. If the responsible party is not on site, it is the responder's responsibility to clean up the spill, gather all wastes together and take them to solid waste.
6. The DOT responder may also choose to call a contractor from the list if the spill is too large or if the spill is not cleaned up within 24 hours. At that point the responsible party can be billed.
7. Contact EOC at 477-3600 and Leigh Simmons from Natural Resources at 533-8135 to notify them of the accident and the current situation. If the responsible party is not cooperating, advise EOC to request a sheriff to the scene.

## Procedure when responding to a spill effecting soil

1. Call DOT Operations at 533-9400 to report the spill. DOT will then send someone from their first responders list to assess the spill.
2. If there is oil running off of the road into the soil, a call must be made to the State Watch Office at (800) 320- 0519 (24 hour/ 7 days)
  - Provide them with the location, type of fluid spilled, how much fluid, who the responsible party is or if there is no responsible party, and their contact info as well as your own. Also, make sure to state “Requesting DEP callback” so that we are sure to get a response. Leave your cell number as you should be receiving a return call within a few minutes.
3. Sand can be put down to stop chemicals from continuing to flow off of the roadway.
4. Set up MOT and stand by until DEP arrives. DEP will handle the clean up if there is no responsible party on site.
5. Contact EOC at 477-3600 and Leigh Simmons from Natural Resources at 533-8135 to notify them of the accident and the current situation. If the responsible party is not cooperating, advise EOC to request a sheriff to the scene.

## **Spill Response Contractors**

SWS Environmental First Response (800) 852-8878

Hoffer & Associates (small spills) (941) 628-0205

Incident Management Solutions Inc. (321) 228-2334

## Responders Checklist

- What is the location of the spill? \_\_\_\_\_
  
- What type of Material is involved? \_\_\_\_\_
  
- Responsible Party:   Name: \_\_\_\_\_  
                                  Address: \_\_\_\_\_  
                                  Phone: \_\_\_\_\_  
                                  Vehicle Description: \_\_\_\_\_  
                                  License Plate: \_\_\_\_\_
  
- Is it ONLY on the roadway? If so, provide the responsible party with the list of available contractors and advise them that they must call and have it cleaned up as soon as possible.
  
- Has it traveled off of the roadway onto the soil? Call the State Watch Office at (800) 320- 0519 and provide them with the above gathered information as well as your name and phone number for a call back. Remember to state, "Requesting DEP callback".
  
- Set up an MOT and stand by until DEP or the contractor arrives.
  
- Is it just a spill with no responsible party on site? If so, and it is ONLY on the roadway, we can clean it up, place it into bags and transport to Solid Waste to be disposed of properly. They will give you a receipt stating what has been given to them which needs to be turned into Joe Frantz. If it has reached the soil, DEP will handle the whole clean up.
  
- Contact EOC at 477-3600 and Leigh Simmons from Natural Resources at 533-8135 to notify them of the accident and the current situation.

**\*\*Remember: Request a sheriff if needed when calling EOC\*\***

## The 2013 Florida Statutes

**376.12 Liabilities and defenses of responsible parties; liabilities of third parties; financial security requirements for vessels; liability of cargo owners; notification requirements.—**

(1) **LIABILITY FOR CLEANUP COSTS.**—Because it is the intent of ss. 376.011-376.21 to provide the means for rapid and effective cleanup and to minimize cleanup costs and damages, any responsible party who permits or suffers a prohibited discharge or other polluting condition to take place within state boundaries shall be liable to the fund for all costs of removal, containment, and abatement of a prohibited discharge, unless the responsible party is entitled to a limitation or defense under this section.

(2) **LIMITATION OF LIABILITY FOR CLEANUP COSTS.**—Except as provided in subsection (3), a responsible party's liability to the fund for costs of removal, containment, and abatement shall be as follows:

(a) For a vessel transporting pollutants as cargo:

1. For any such vessel of 3,000 gross tons or more, \$10 million or \$1,200 per gross ton, whichever is greater.

2. For any such vessel of less than 3,000 gross tons, \$2 million or \$1,200 per gross ton, whichever is greater.

(b) For any other vessel: \$500,000 or \$600 per gross ton, whichever is greater.

(c) For a terminal facility: \$150 million.

(3) **EXCEPTIONS TO LIMITATION OF LIABILITY.**—The provisions of subsection (2) shall not apply when:

(a) The department demonstrates that such discharge was the result of willful or gross negligence or willful misconduct of, or the violation of an applicable federal or state safety, construction, or operating regulation or rule by, the responsible party, an agent or employee of the responsible party, or a person acting pursuant to a contractual relationship with the responsible party, except where the sole contractual arrangement arises in connection with carriage by a common carrier by rail; or

(b) The responsible party fails or refuses:

1. To report the incident as required by law and the responsible party knows or has reason to know of the incident; or

2. To provide reasonable cooperation and assistance requested by a state or federal on-scene coordinator in connection with cleanup activities. The responsible party must file an objection with the department if such party deems that cooperation or assistance requested by a state or federal on-scene coordinator is unreasonable. Such an objection must be filed with the department within 2 working days after the request. If such request is determined by the department to be unreasonable,

the responsible party may assert a claim against the fund, pursuant to s. 376.123, for reimbursement of expenses incurred in carrying out such request. The responsible party may not file an objection to a request based solely on the premise that the requested activity did not have satisfactory results, that the responsible party has exceeded the applicable limitation of liability, or that the responsible party has a defense to liability.

(4) LIABILITY FOR NATURAL RESOURCE DAMAGES.—Each responsible party is liable to the fund, pursuant to s. 376.121, for all natural resource damages that result from the discharge.

(5) LIABILITY FOR PROPERTY DAMAGES.—Each responsible party is liable to any affected person for all damages as defined in s. 376.031, excluding natural resource damages, suffered by that person as a result of the discharge.

<sup>1</sup>(6) ADMINISTRATIVE REMEDIES OF RESPONSIBLE PARTIES.—A responsible party that disputes any claim by the department may request a hearing pursuant to s. 120.57.

(7) DEFENSES TO LIABILITY.—In any proceeding determining claims of the fund or any other claims by the state pursuant to ss. 376.011-376.21, it shall not be necessary for the department to plead or prove negligence in any form or manner. The department need only plead and prove that the prohibited discharge or other polluting condition occurred. The only defenses of a person alleged to be responsible for the discharge to an action or proceeding for damages or cleanup costs shall be to plead and prove that the occurrence was solely the result of any of the following or any combination of the following:

- (a) An act of war.
- (b) An act of government, either federal, state, county, or municipal.
- (c) An act of God, which means only an unforeseeable act exclusively occasioned by the violence of nature without the interference of any human agency.
- (d) An act or omission of a third party other than an employee or agent of the responsible party or a third party whose act or omission occurs in connection with any contractual relationship with the responsible party, except where the sole contractual arrangement arises in connection with carriage by rail,

provided that, to establish entitlement to any of the foregoing defenses, the responsible party shall plead and prove that the responsible party exercised due care with respect to the pollutant concerned, taking into consideration the characteristics of the pollutant and in light of all relevant facts and circumstances, and took precautions against foreseeable acts or omissions of others and the foreseeable consequences of those acts or omissions.

(8) EXCEPTIONS TO DEFENSES.—The defenses provided in subsection (7) shall not apply with respect to a responsible party who fails or refuses:



(a) To report the discharge as required by law, when the responsible party knows or has reason to know of the discharge; or

(b) To provide reasonable cooperation and assistance requested by a state or federal on-scene coordinator in connection with cleanup activities. The responsible party must file an objection with the department, pursuant to subsection (3), if such party deems that cooperation or assistance requested by a state or federal on-scene coordinator is unreasonable.

(9) LIABILITY OF THIRD PARTIES.—In any case in which a responsible party establishes that a discharge or threat of a discharge and the resulting cleanup costs and damages were caused solely by an act or omission of one or more third parties as described in paragraph (7)(d), or solely by such an act or omission in combination with an act of war, an act of government, or an act of God, the third party or parties shall be treated as the responsible party or parties for all purposes of determining liability under ss. 376.011-376.21.

(10) LIABILITY OF CARGO OWNERS.—The owner of a pollutant transported as cargo on any vessel suffering a discharge within state waters is liable for all cleanup costs within the applicable vessel liability limits established under this section, not paid for by the owner or operator of the vessel. However, the cargo owner is not liable under this subsection if the vessel owner, operator, or master is found in compliance with the financial security requirements of this section at the time of the discharge or fails to provide certified notification of the cancellation or withdrawal of financial security to the department and the cargo owner at least 3 working days before the vessel entered state waters.

(11) NOTIFICATION REQUIREMENTS FOR VESSELS AND TERMINAL FACILITIES.—In addition to any civil penalties which may apply, any person responsible who fails to give immediate notification of a discharge to the department or the nearest Coast Guard Marine Safety Office or National Response Center commits a felony of the third degree, punishable as provided in s. 775.082, s. 775.083, or s. 775.084. However, a discharge of 5 gallons or less of gasoline or diesel from a vessel shall not give rise to felony penalties for failure to comply with the state notification requirements in this subsection. After reporting a discharge, a vessel shall remain in the jurisdiction of the department until such time as the department is able to prove financial responsibility for the damages resulting from the discharge. The master of a vessel that fails to remain in the jurisdiction of the department for a reasonable time after notice of a discharge commits a felony of the third degree, punishable as provided in s. 775.082, s. 775.083, or s. 775.084. The department shall not detain the vessel longer than 12 hours after receiving proof of financial responsibility. The department shall, by rule, require that the terminal facility designate a person at the terminal facility as the person in charge of that facility for the purposes specified by this section.

### Other Spills

1. Well Field Spills- Refer to the attached map. Any spills in those areas need to be immediately reported to Lee Werst at (239) 533-8136. If you do not reach him, please call his cell at (239) 851-7709.
2. If you notice sheen on top of coastal waterways (water of the state), the coastguard will get involved by calling the National Response Center at (800) 424-8802.